



SERVICE MANUAL

BATTERY HEDGE TRIMMER

ECHO: DHCAS-2600HD

(Serial number : E82835001001 - E82835999999)

Reference No. 24-012-EN
ISSUED : 202503

Introduction

This manual contains description for the maintenance and repair on this product.

Technical improvement of this product can cause changes to the maintenance, repair and spare parts. All specifications, illustrations and directions in this manual are based on the latest product information available at the time of publication.

Specifications are subject to change without notice.

Safety Alert Symbols

Safety messages in this manual are identified by the words "DANGER", "WARNING", "CAUTION", and "NOTICE."

The meanings are as follows.

DANGER

- The safety alert symbol accompanied by the word "DANGER" calls attention to an act or condition which WILL lead to serious personal injury or death if not avoided.

CAUTION

- The safety alert symbol accompanied by the word "CAUTION" calls attention to an act or condition which might lead to minor or moderate personal injury if not avoided.

WARNING

- The safety alert symbol accompanied by the word "WARNING" calls attention to an act or condition which CAN lead to serious personal injury or death if not avoided.

NOTICE

- The enclosed message provides information necessary for the protection of the unit.

Trademarks

TORX is a registered trademark of Acument Intellectual Properties, LLC.

1 Basic Information	3		
1-1 Product Specifications	3		
1-2 Torque Limits	4		
1-3 Required Tools and Special Maintenance Materials	10		
1-4 Disassembly Chart	11		
1-5 Wiring Diagram	12		
2 Troubleshooting.....	13		
2-1 Flow of Troubleshooting	13		
2-2 Power Indicator Error Display	14		
2-3 Diagnosis with Maintenance Mode	15		
2-4 List of Maintenance Mode Error Numbers and Remedies	17		
2-5 Troubleshooting "STEP 0" (Error Diagnosis)	18		
2-6 Troubleshooting "STEP 1" (Check the Battery and Charger)	19		
2-7 Troubleshooting "STEP 2" (Check the Unit When Battery Failure Occurs)	21		
2-8 Troubleshooting "STEP 3" (Check the Power Supply Circuit)	22		
2-9 Troubleshooting "STEP 4" (Check Low Voltage and Over-Discharge)	24		
2-10 Troubleshooting "STEP 5" (Check Each Sensor of Battery)	26		
2-11 Troubleshooting "STEP 6" (Check the Overload)	28		
2-12 Troubleshooting "STEP 7" (Check Other Failures).....	30		
3 Inspect the Battery and Charger	33		
3-1 Battery Components	33		
3-2 Charger Components	33		
3-3 Cautions for Using Battery and Charger	33		
3-4 LED Charge Level Indicator	33		
3-5 Charging Status Indicator	33		
3-6 Inspect the Battery Voltage	34		
3-7 Inspect for Damage from Over-Discharging	35		
3-8 Inspect the Battery Temperature Sensor	35		
4 Disassemble/Assemble the Motor and Control Board Assembly.....	37		
4-1 Motor and Control Board Assembly Components	37		
4-2 Remove/Attach the Battery Holder	38		
4-3 Remove the Motor Cover	38		
4-4 Attach the Motor Cover	39		
4-5 Remove the Motor Assembly	40		
4-6 Attach the Motor Assembly	41		
		4-7 Remove the Control Board Assembly	42
		4-8 Attach the Control Board Assembly	42
		5 Disassemble/Assemble the Switch and Trigger	44
		5-1 Switch and Trigger Components	44
		5-2 Remove/Attach the Trigger Holder	45
		5-3 Remove the Trigger Parts	46
		5-4 Attach the Trigger Parts	46
		5-5 Remove the Power Switch	47
		5-6 Attach the Power Switch	47
		5-7 Remove/Attach the Variable Speed Switch	48
		5-8 Remove the Interlock Switch Cover	49
		5-9 Attach the Interlock Switch Cover	49
		5-10 Remove the Interlock Switch	50
		5-11 Attach the Interlock Switch	51
		6 Disassemble/Assemble the Upper Gear Case	54
		6-1 Upper Gear Case Components	54
		6-2 Remove the Upper Gear Case	56
		6-3 Attach the Upper Gear Case	58
		6-4 Remove/Attach the Release Lever and Safety Lever	61
		7 Disassemble/Assemble the Lower Gear Case	62
		7-1 Lower Gear Case Components	62
		7-2 Remove the Lower Gear Case	63
		7-3 Attach the Lower Gear Case	64
		8 Disassemble/Assemble the Cutter	67
		8-1 Cutter Components	67
		8-2 Remove the Cutter Assembly	68
		8-3 Attach the Cutter Assembly	68
		8-4 Remove the Cutter	70
		8-5 Attach the Cutter	71
		9 Disassemble/Assemble the Main Pipe and Flexible Shaft	73
		9-1 Main Pipe and Flexible Shaft Components	73
		9-2 Remove/Attach the Main Pipe and Flexible Shaft	74
		9-3 Remove/Attach the Main Pipe Fixture	75
		10 Inspect the Various Parts	76
		10-1 Inspect the Motor Assembly	76
		10-2 Inspect the Control board assembly	76
		10-3 Inspect the Power Switch	77

10-4 Inspect the Variable Speed Switch	79
10-5 Inspect the Interlock Switch	80
10-6 Sharpen the Cutter	81

1. Basic Information

1-1 Product Specifications

Item		Unit	Details	
Dimensions* ¹	Length	mm (in)	2198 (86.5)	
	Width	mm (in)	177 (7.0)	
	Height	mm (in)	173 (6.8)	
Weight* ²		kg (lb)	4.3 (9.5)	
Motor	Type	-	Brushless motor	
	Rotation direction	-	Counterclockwise as viewed from the output end	
	Rated current	A	19.4	
	Rated voltage	V	50.4	
	Rated output	kW	0.8	
	Speed control	-	Variable	
Battery	Standard battery	-	LBP-50-150	LBP50-250
	Type	-	Lithium-ion	
	Rated voltage	V	50.4	
	Capacity	Ah / Wh	2.25 / 113	4.5 / 226
	Charging time	min.	30 (80%), 47 (100%)	LCJQ-560: 60 (80%), 89 (100%) LCJU-560: 30 (80%), 57 (100%)
	Run time on a single charge* ³	min.	Hi : Up to 36 Mid : Up to 45 Lo : Up to 54	Hi : Up to 72 Mid : Up to 87 Lo : Up to 103
Battery charger	Standard charger	-	LCJQ-560, LCJU-560	
	Input voltage	-	AC220-240	
Main pipe	Outer diameter	mm (in)	25.0 (0.98)	
	Inner diameter	mm (in)	22.0 (0.87)	
	Length	mm (in)	1215 (47.83)	
Drive shaft	Type	-	Flexible shaft	
	Outer diameter	mm (in)	6.1 (0.24)	
	Length	mm (in)	1237 (48.70)	
Gear case	Reduction ratio	-	4.6	
	Lubrication	-	Lithium based grease	
Cutter	Type	double sided blade	Dual action, double sided blade	
	Effective length	mm (in)	536 (21.1)	
	Pitch	mm (in)	35 (1.4)	
	Height	mm (in)	21 (0.8)	
	Thickness	mm (in)	2 (0.1)	
	Strokes per minute	-	Hi: 2300 Lo: 1750	

*¹ With the cutter blades opened 180° from the closed position.

*² Without battery and blade cover

*³ Depending on battery size, charge level and operating conditions.

1-2 Torque Limits

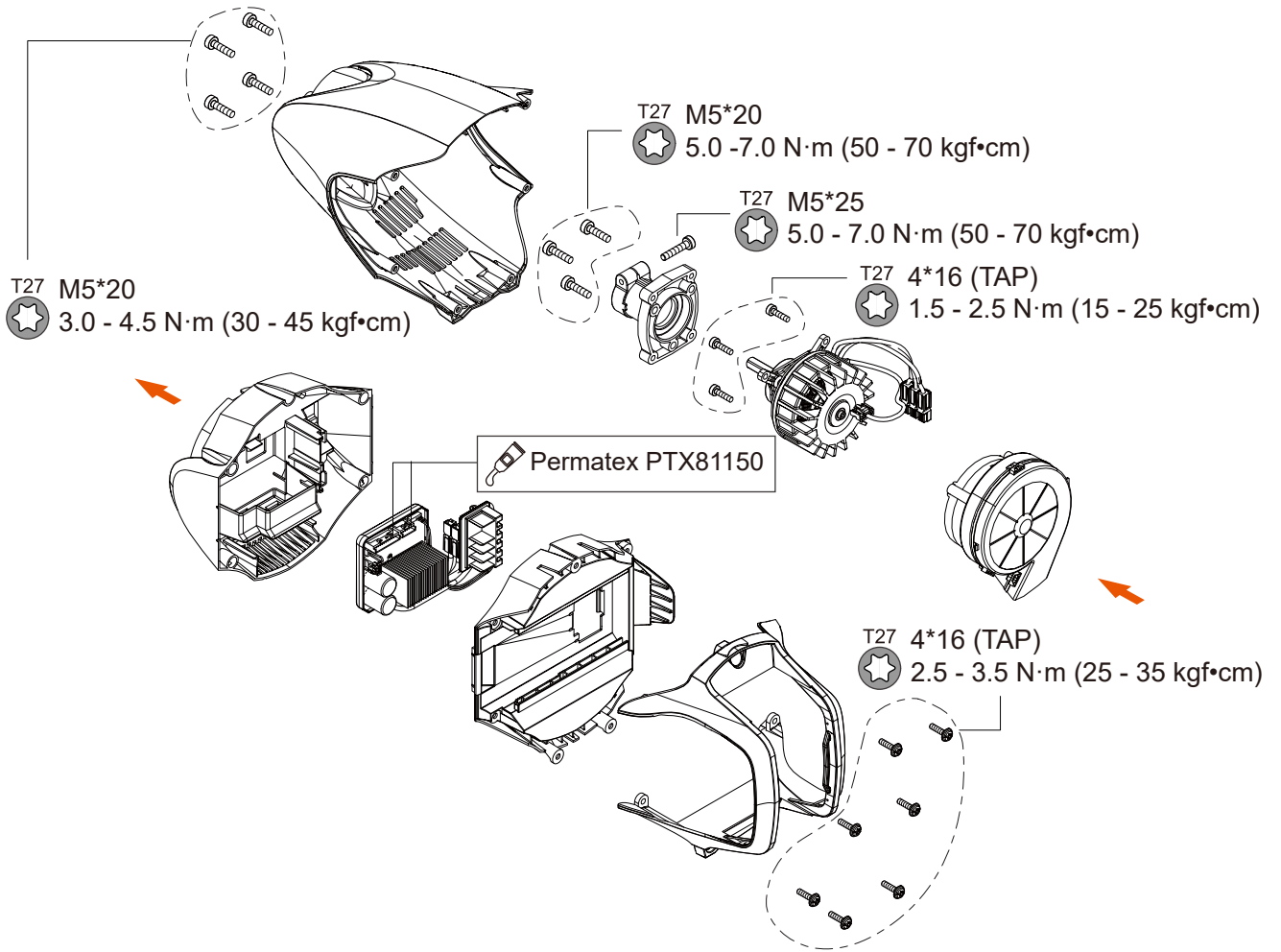

Figure : Torque Limits (1)

Remark

TAP : Tapping

 : Apply lithium-based grease to part

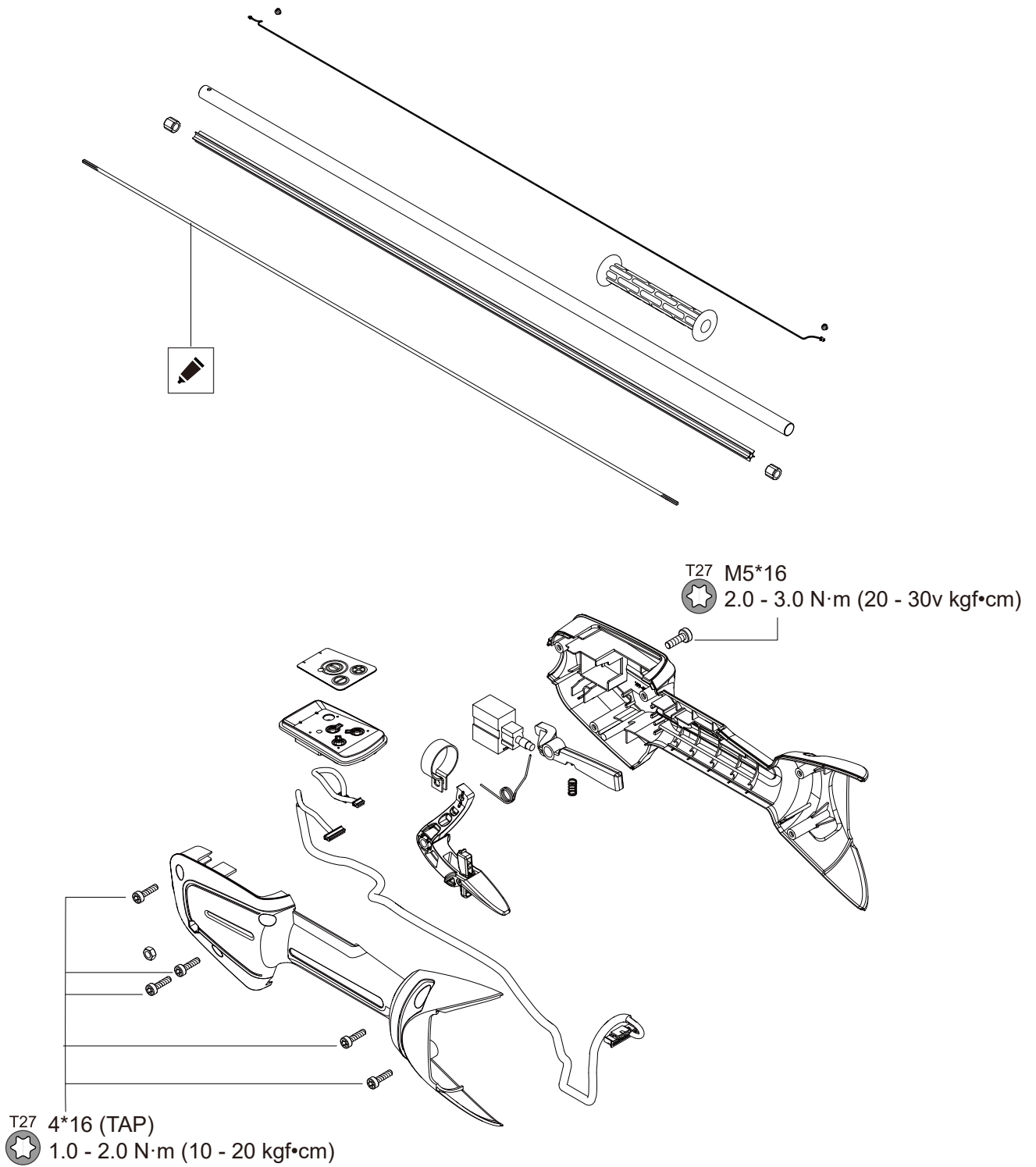

Figure : Torque Limits (2)

Remark

TAP : Tapping

 : Apply lithium-based grease to part

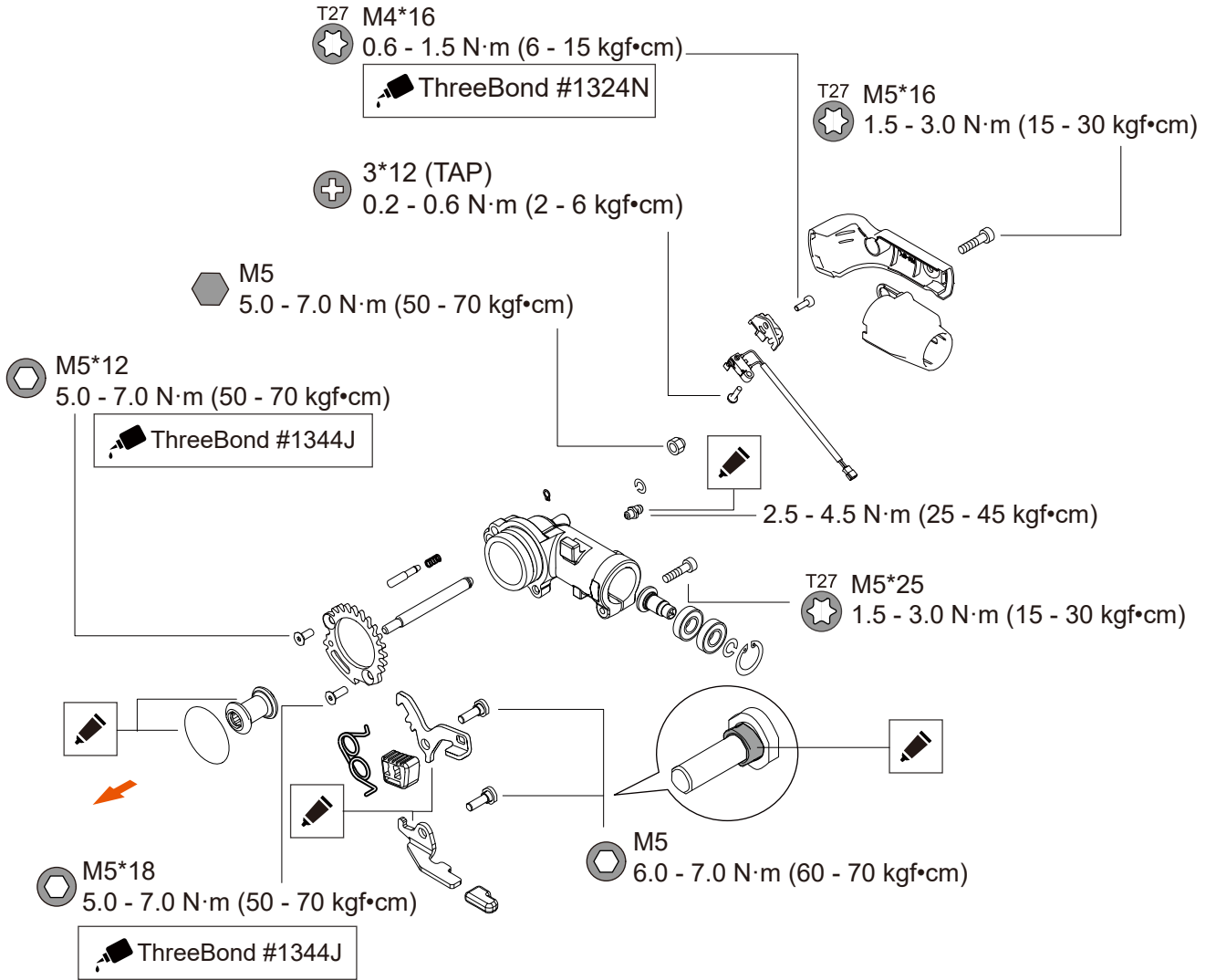

Figure : Torque Limits (3)

Remark

TAP : Tapping

 : Apply lithium-based grease to part

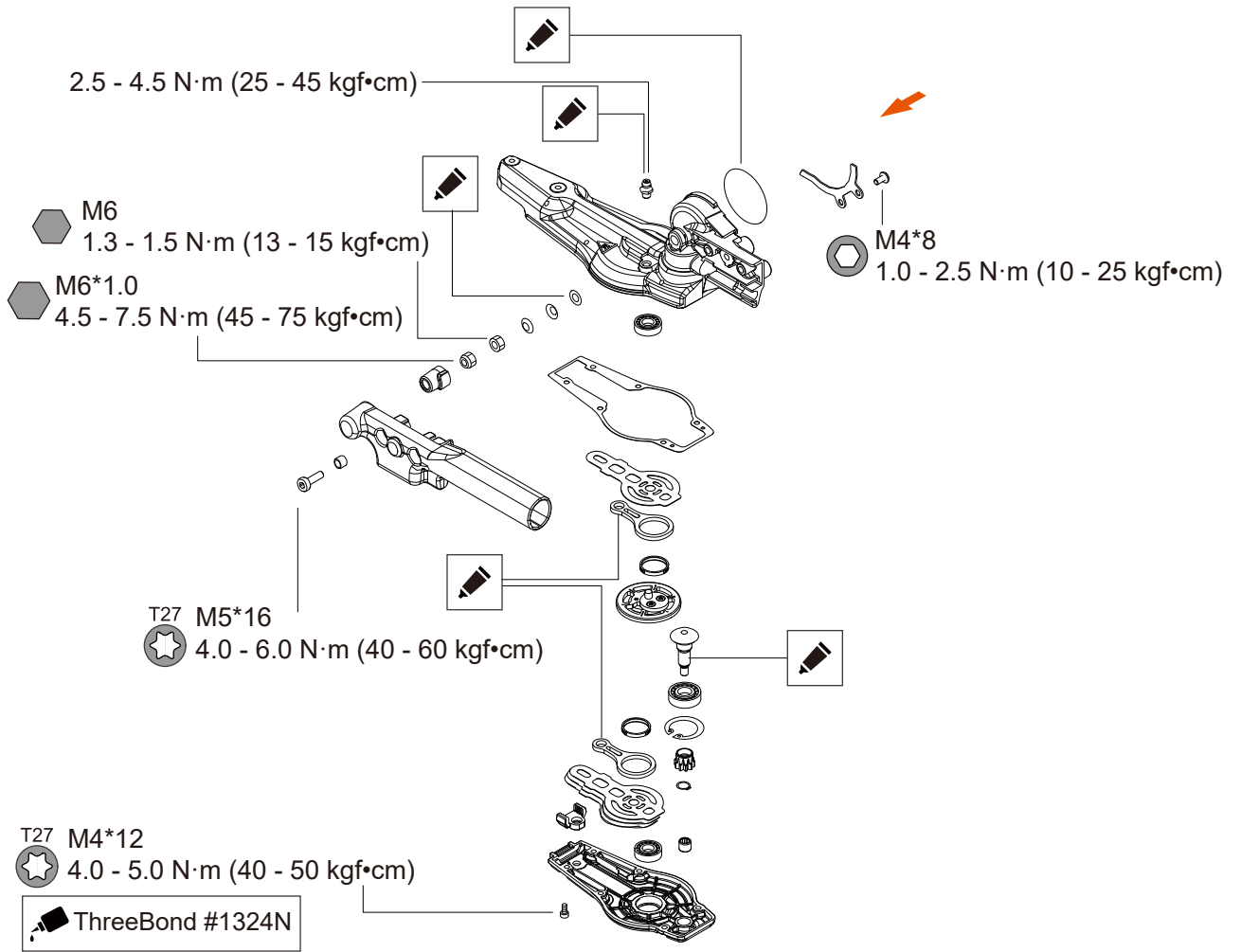



Figure : Torque Limits (4)

Remark

TAP : Tapping

 : Apply lithium-based grease to part

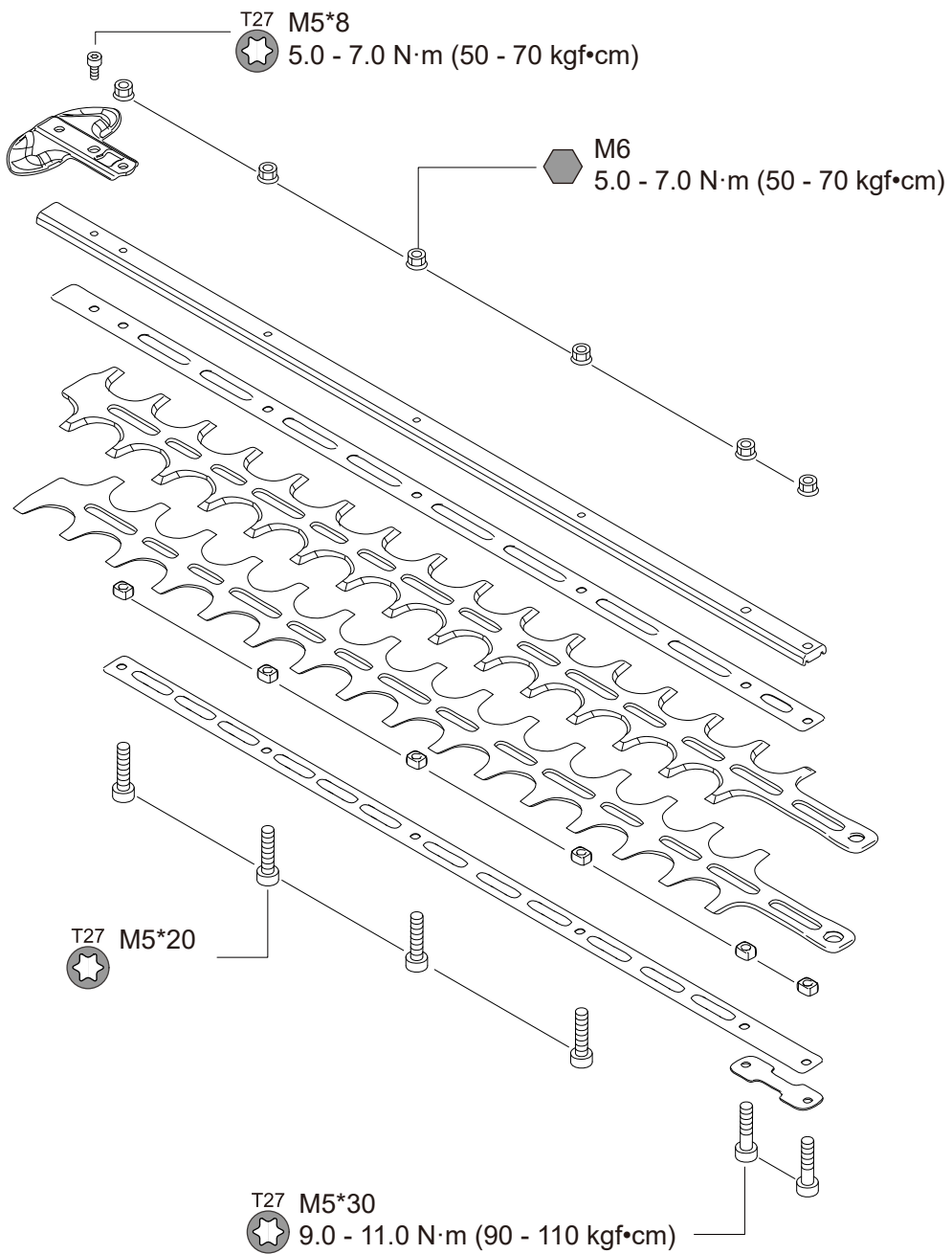

Figure : Torque Limits (5)

Remark

TAP : Tapping

 : Apply lithium-based grease to part

Related Topics

- [1-3 Required Tools and Special Maintenance Materials \(p.10\)](#)

1-3 Required Tools and Special Maintenance Materials

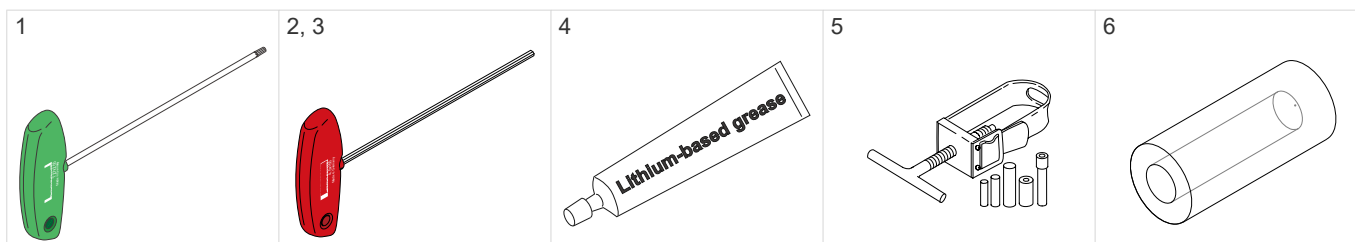

	Part Number	Part Name	Use
1	X602-000340	Torx wrench (T27)	To loosen/tighten Torx bolts
2	X602-000350	T-hex wrench(M4)	To loosen/tighten Hex. head bolts
3	X602-000360	T-hex wrench(M5)	To loosen/tighten Hex. head bolts
4	X695-000060	Lithium-based grease	To lubricate gear case housing
5	897702-30131	Piston pin tool	To remove/install gear shaft
6	897726-09130	Oil seal tool	To insert ballbearig and needle bearing

1-4 Disassembly Chart

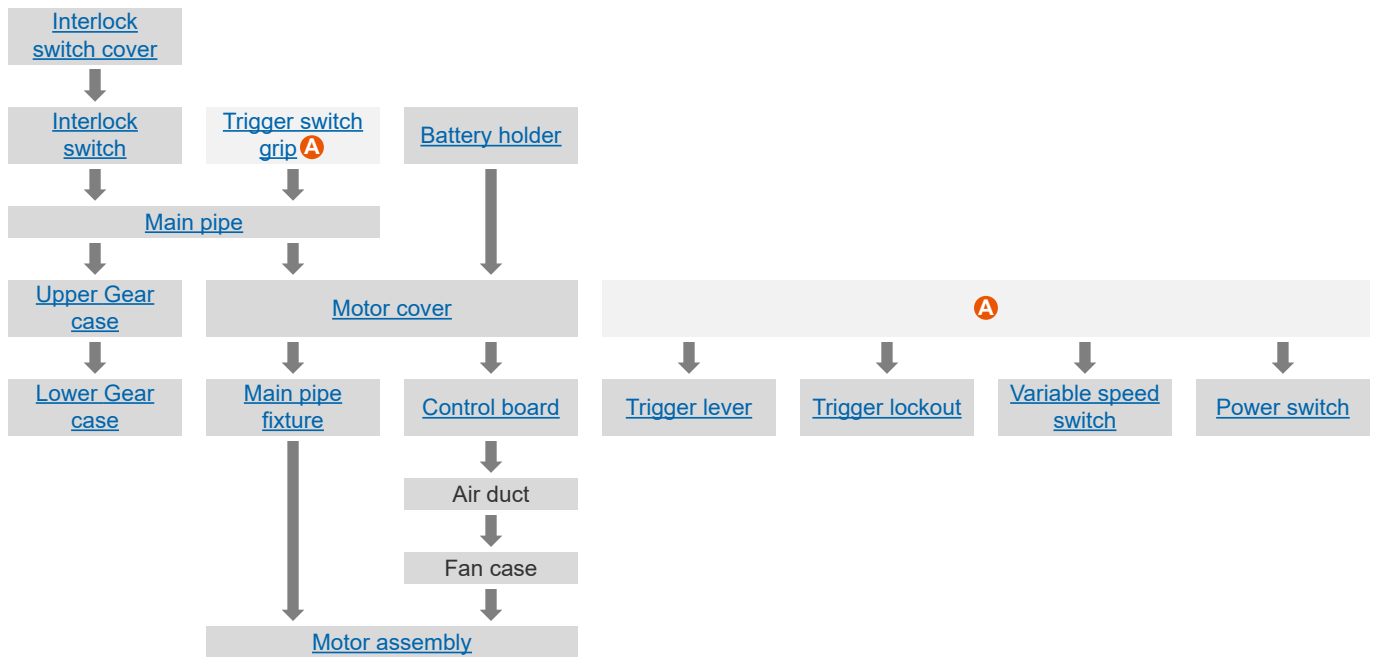

Related Topics

- [5-8 Remove the Interlock Switch Cover \(p.49\)](#)
- [4-2 Remove/Attach the Battery Holder \(p.38\)](#)
- [5-10 Remove the Interlock Switch \(p.50\)](#)
- [5-3 Remove the Trigger Parts \(p.46\)](#)
- [9-2 Remove/Attach the Main Pipe and Flexible Shaft \(p.74\)](#)
- [6-2 Remove the Upper Gear Case \(p.56\)](#)
- [7-2 Remove the Lower Gear Case \(p.63\)](#)
- [4-5 Remove the Motor Assembly \(p.40\)](#)
- [4-7 Remove the Control Board Assembly \(p.42\)](#)
- [5-2 Remove/Attach the Trigger Holder \(p.45\)](#)
- [5-5 Remove the Power Switch \(p.47\)](#)
- [5-7 Remove/Attach the Variable Speed Switch \(p.48\)](#)

1-5 Wiring Diagram

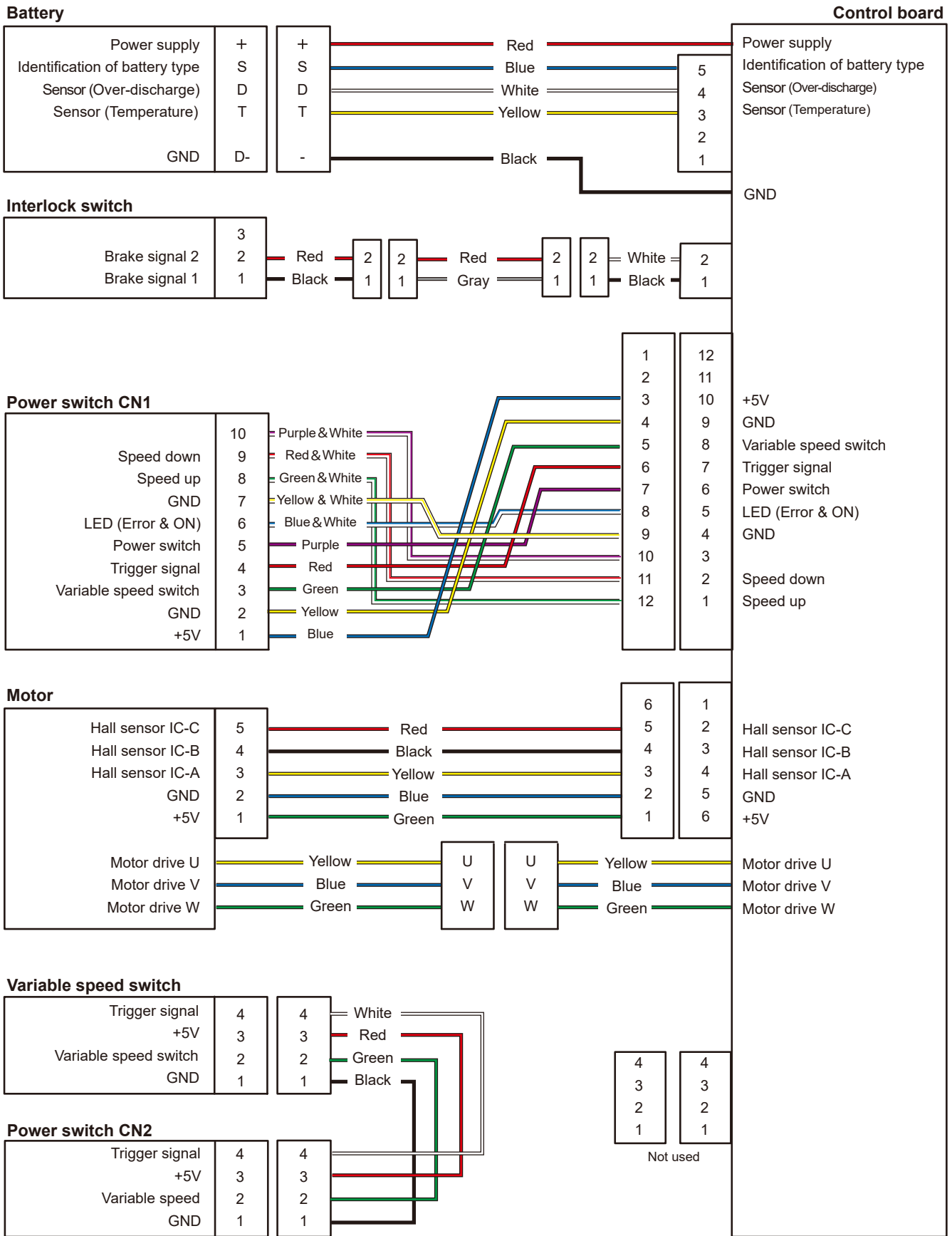

2. Troubleshooting

2-1 Flow of Troubleshooting

Problems with the unit may have several causes.

Perform troubleshooting according to the flow below in order to identify the cause of the problem.

(1) Checking the power indicator

The flashing of the power indicator enables you to identify possible error causes.

(2) Diagnosis with the maintenance mode

The unit has a maintenance mode that can be used for diagnosis.

You can operate the unit to check the error number indicating the most recent error.

(3) Troubleshooting flow

If you cannot solve the problem with the maintenance mode, perform troubleshooting via the flow indicated below.

Start troubleshooting from flow **STEP 0**.

STEP 0 Error diagnosis

STEP 1 Checking the battery and the charger

STEP 2 Checking the unit when battery failure occurs

STEP 3 Checking the power supply circuit

STEP 4 Checking low voltage and over-discharge

STEP 5 Checking each sensor of the battery

STEP 6 Checking the overload

STEP 7 Checking other failures

2-2 Power Indicator Error Display

The flashing of the power indicator **A** enables you to identify possible error causes.

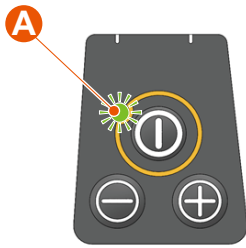

Figure : Power switch

Slow flashing (1 time/second)

- Low battery voltage
- Battery voltage too low to charge
- The battery sensor has a bad connection, or is disconnected.
- The capacitor is damaged.

Fast flashing (4 times/second)

- The cutter blades are in closed position.
- The battery voltage is too high.
- The battery is too hot or too cold.
- The unit is too hot or too cold.
- No electric current flows to the motor.
- The motor speed does not reach the set speed because a load is applied when the motor is started.
- The hall sensor is defective, or disconnected.
- The variable speed switch is defective, or disconnected.
- The board is defective.

2-3 Diagnosis with Maintenance Mode

CAUTION

- Do not pull the trigger lever. The blade may run unexpectedly.

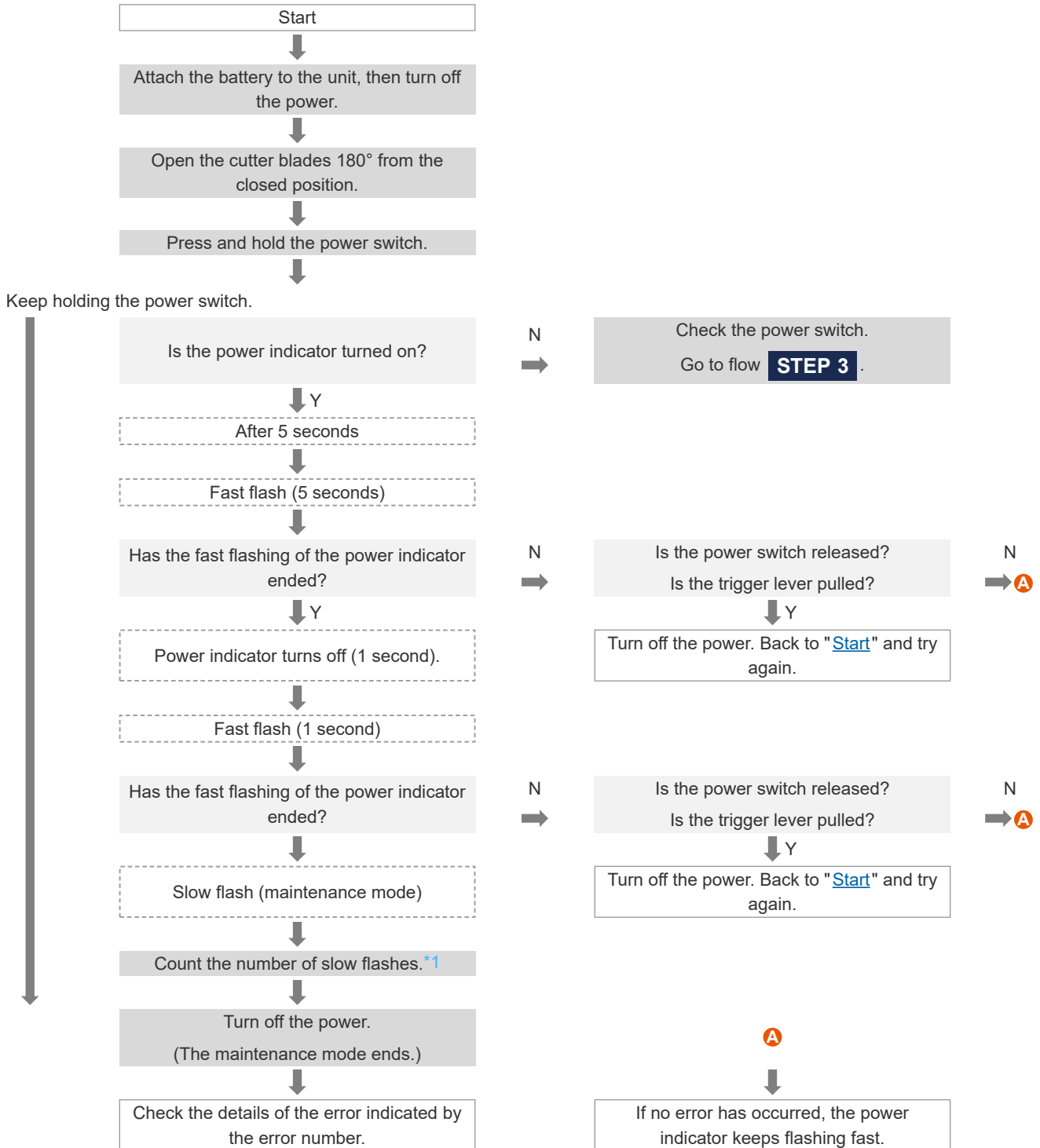

Remark

- Y: Yes
- N: No

*1 The power indicator alternates between slow flashes indicating the error number and fast flashes indicating a pause.

Related Topics

- [2-4 List of Maintenance Mode Error Numbers and Remedies \(p.17\)](#)
- [2-8 Troubleshooting "STEP 3" \(Check the Power Supply Circuit\) \(p.22\)](#)

2-4 List of Maintenance Mode Error Numbers and Remedies

You can identify the error number by counting the number of slow power indicator flashes in the maintenance mode.

The error number indicates the most recent error. Maintenance mode retains the last error number after the error is resolved. Error numbers are not deleted unless another error occurs.

The causes and remedies of each error number are indicated below.

Error number	Possible cause	Remedy
1	The battery voltage is too low, or disconnected.	Check the battery voltage. Check the battery Over-discharge sensor.
2 to 4	The capacitor is damaged.	Replace the control board assembly.
5 to 8	The battery voltage is too high.	Check the battery voltage.
9	The battery is too hot.	Wait for the battery to cool down. Check the battery temperature sensor.
10	The battery is too cold.	Wait for the battery to warm up. Check the battery temperature sensor.
11	The unit is too hot.	Wait for the unit to cool down.
12	The unit is too cold.	Wait for the unit to warm up.
15 to 21	Program protection function	Turn off the power switch and then turn the power switch on again.
22	The motor is ready to run, but no electric current flows to the motor.	Check the motor connectors.
23	The motor speed does not reach the set speed because a load is applied when the motor is started.	Turn off the power switch and then remove the load.
24 to 25	The hall sensor is defective.	Inspect the motor assembly.
26	The hall sensor is defective, or disconnected.	Inspect the motor assembly.
27	The variable speed switch is defective, or disconnected.	Inspect the variable speed switch.
28	Program protection function	Turn off the power switch and then turn the power switch on again.

Related Topics

- [4-7 Remove the Control Board Assembly \(p.42\)](#)
- [4-8 Attach the Control Board Assembly \(p.42\)](#)
- [3-6 Inspect the Battery Voltage \(p.34\)](#)
- [3-8 Inspect the Battery Temperature Sensor \(p.35\)](#)
- [10-1 Inspect the Motor Assembly \(p.76\)](#)

2-5 Troubleshooting "STEP 0" (Error Diagnosis)

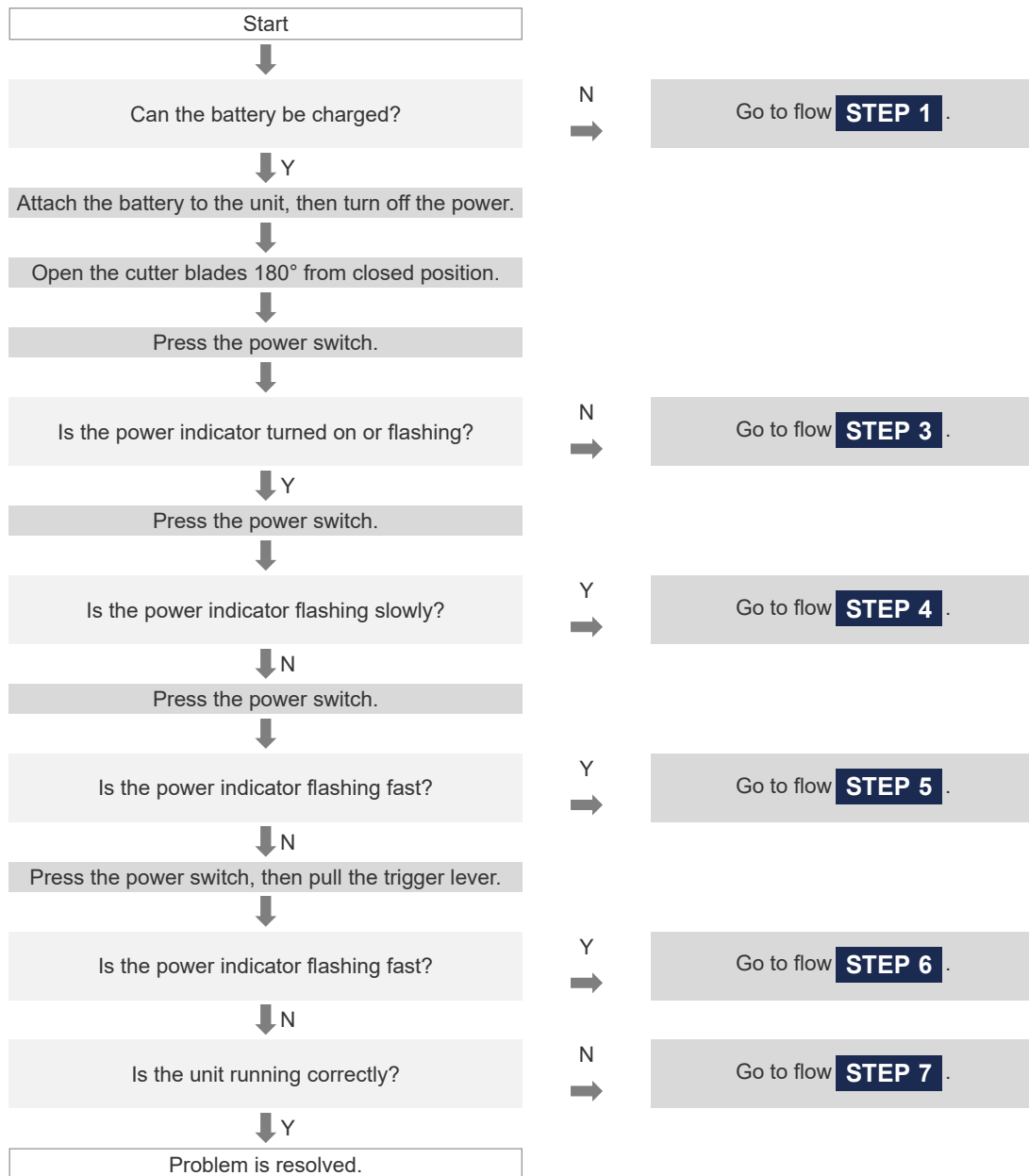

Remark

Y : Yes

N : No

Related Topics

- [2-6 Troubleshooting "STEP 1" \(Check the Battery and Charger\) \(p.19\)](#)
- [2-7 Troubleshooting "STEP 2" \(Check the Unit When Battery Failure Occurs\) \(p.21\)](#)
- [2-8 Troubleshooting "STEP 3" \(Check the Power Supply Circuit\) \(p.22\)](#)
- [2-9 Troubleshooting "STEP 4" \(Check Low Voltage and Over-Discharge\) \(p.24\)](#)
- [2-10 Troubleshooting "STEP 5" \(Check Each Sensor of Battery\) \(p.26\)](#)
- [2-11 Troubleshooting "STEP 6" \(Check the Overload\) \(p.28\)](#)
- [2-12 Troubleshooting "STEP 7" \(Check Other Failures\) \(p.30\)](#)

2-6 Troubleshooting "STEP 1" (Check the Battery and Charger)

NOTICE

- If the unit is defective, it may also damage the new battery when the battery is replaced with a new one. Before replacing the battery, perform flow **STEP 2** to check the unit for problems other than the battery.

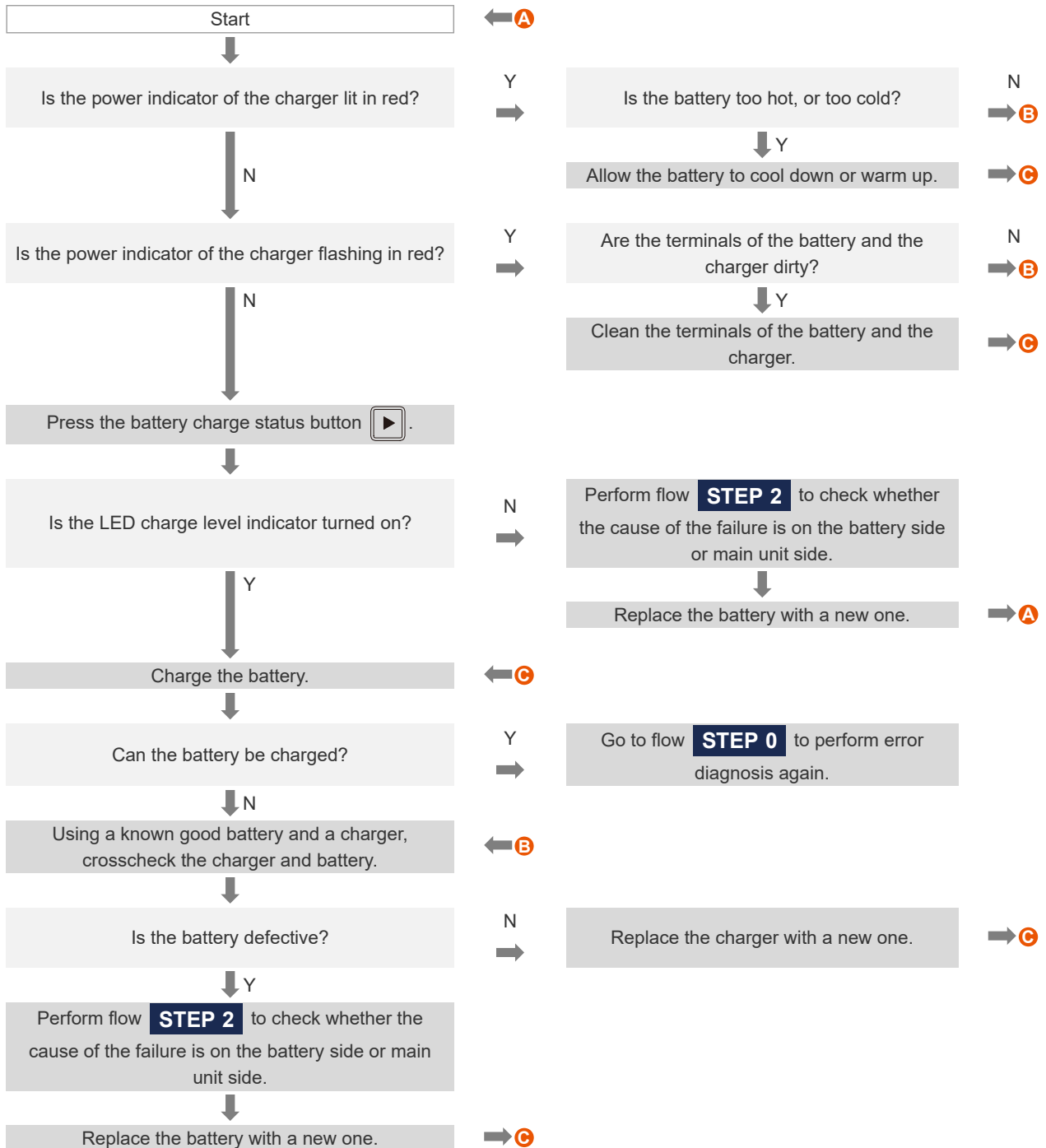

Remark

Y : Yes
 N : No

Related Topics

- [2-5 Troubleshooting "STEP 0" \(Error Diagnosis\) \(p.18\)](#)
- [2-7 Troubleshooting "STEP 2" \(Check the Unit When Battery Failure Occurs\) \(p.21\)](#)

2-7 Troubleshooting "STEP 2" (Check the Unit When Battery Failure Occurs)

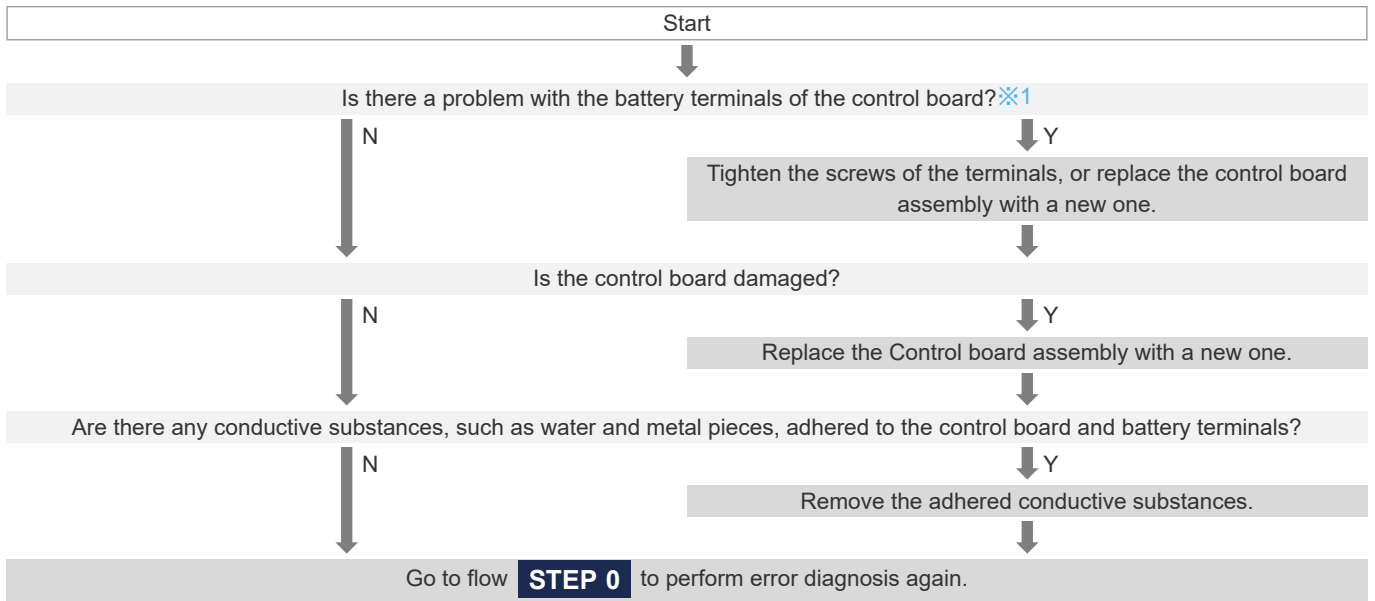

Remark

Y : Yes
N : No

※1 Inspect the battery terminals of the control board for the following problems.

- There is a short-circuit between the positive [+] terminal and the negative [-] terminal.
- The screws of the battery terminals are loose or disconnected.
- No electric current can flow in the positive [+] and negative [-] terminal wires.

関連項目

- [10-2 Inspect the Control board assembly \(p.76\)](#)
- [4-7 Remove the Control Board Assembly \(p.42\)](#)
- [4-8 Attach the Control Board Assembly \(p.42\)](#)
- [2-5 Troubleshooting "STEP 0" \(Error Diagnosis\) \(p.18\)](#)

2-8 Troubleshooting "STEP 3" (Check the Power Supply Circuit)

⚠ WARNING

- Perform troubleshooting in safe, clear surroundings. The unit may run unexpectedly.

⚠ CAUTION

- Do not pull the trigger lever when the cutter blades are open. The cutter blades may run unexpectedly.

NOTICE

- If the unit is defective, it may also damage the new battery when the battery is replaced with a new one.

Before replacing the battery, perform flow **STEP 2** to check the unit for problems other than the battery.

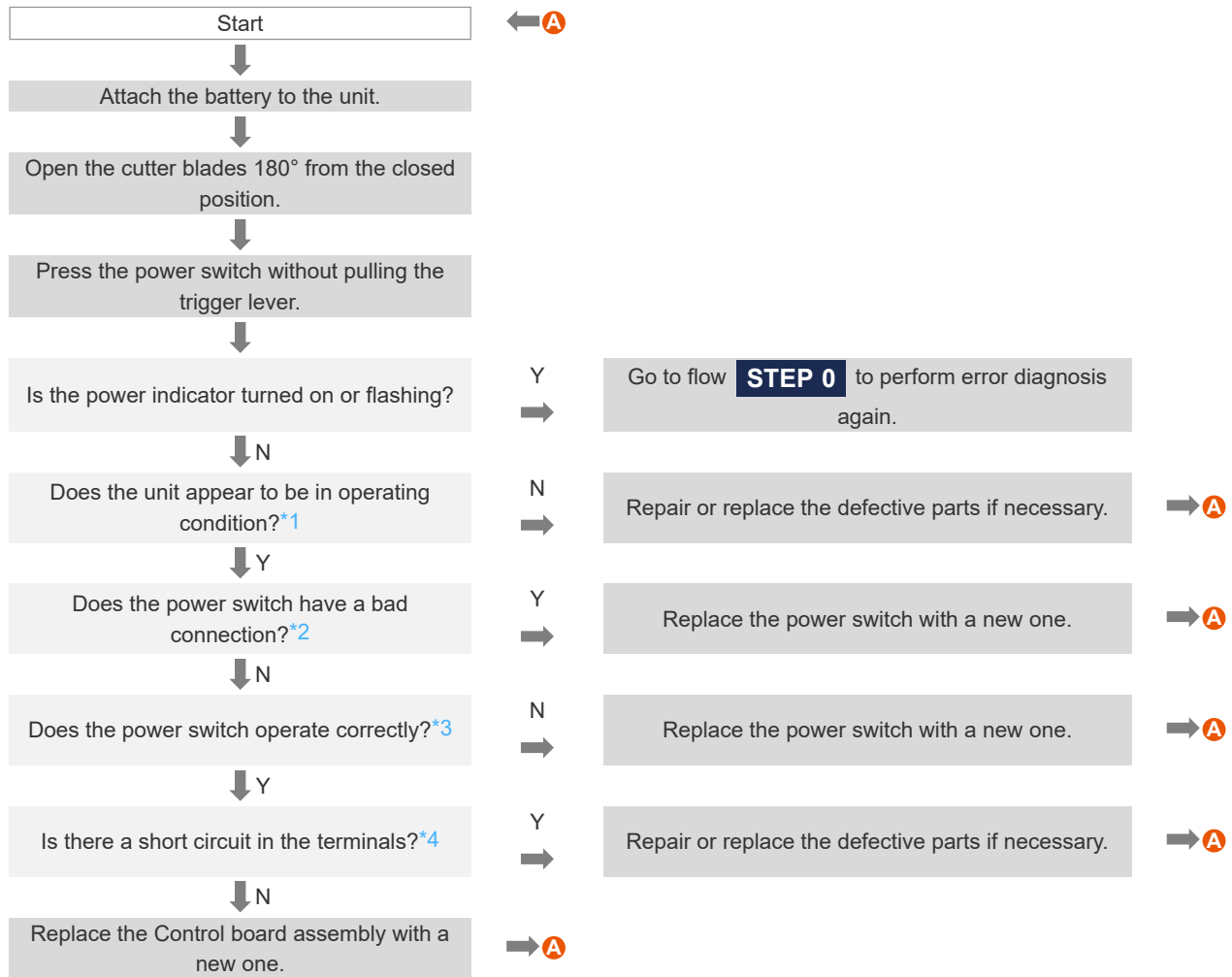

Remark

Y : Yes
 N : No

*1 Inspect the unit for the following:

- Each connector is connected securely.
- Each wire is connected to each connector securely.
- All the wires are intact.

*2 Inspect the following.

- When the power switch button is pressed : An electric current flows between terminals [2] and [5].
- When the power switch button is released : No electric current flows between terminals [2] and [5].
- When the + button is pressed : An electric current flows between terminals [2] and [8].
- When the + button is released : No electric current flows between terminals [2] and [8].
- When the - button is pressed : An electric current flows between terminals [2] and [9].
- When the - button is released : No electric current flows between terminals [2] and [9].

*3 Apply an electric current between terminals [1] and [6] of the power switch. The power indicator should turn on.

*4 Inspect the following terminals for a short circuit.

- Between terminals [1] and [2] of the power switch
- Between terminals [1] and [3] of the variable speed switch
- Between terminals [1] and [2] of the motor assembly 5-pole terminal block.

Related Topics

- [3-8 Inspect the Battery Temperature Sensor \(p.35\)](#)
- [10-3 Inspect the Power Switch \(p.77\)](#)
- [10-1 Inspect the Motor Assembly \(p.76\)](#)
- [5-5 Remove the Power Switch \(p.47\)](#)
- [5-6 Attach the Power Switch \(p.47\)](#)
- [4-7 Remove the Control Board Assembly \(p.42\)](#)
- [4-8 Attach the Control Board Assembly \(p.42\)](#)
- [2-5 Troubleshooting "STEP 0" \(Error Diagnosis\) \(p.18\)](#)
- [2-7 Troubleshooting "STEP 2" \(Check the Unit When Battery Failure Occurs\) \(p.21\)](#)

2-9 Troubleshooting "STEP 4" (Check Low Voltage and Over-Discharge)

NOTICE

- If the unit is defective, it may also damage the new battery when the battery is replaced with a new one.

Before replacing the battery, perform flow **STEP 2** to check the unit for problems other than the battery.

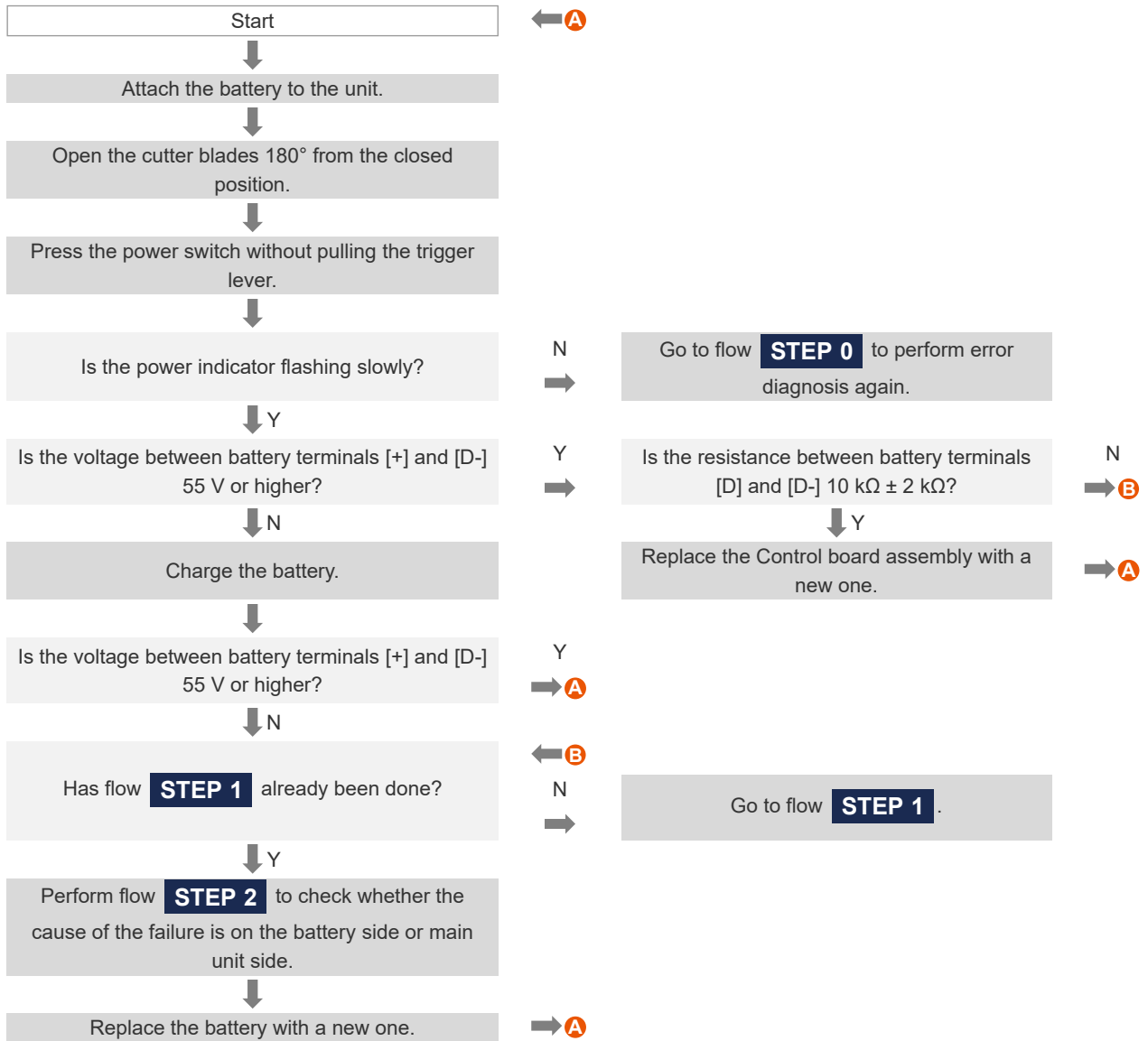

Remark

Y : Yes
 N : No

Related Topics

- [3-6 Inspect the Battery Voltage \(p.34\)](#)
- [3-7 Inspect for Damage from Over-Discharging \(p.35\)](#)
- [4-7 Remove the Control Board Assembly \(p.42\)](#)
- [4-8 Attach the Control Board Assembly \(p.42\)](#)
- [2-5 Troubleshooting "STEP 0" \(Error Diagnosis\) \(p.18\)](#)
- [2-6 Troubleshooting "STEP 1" \(Check the Battery and Charger\) \(p.19\)](#)
- [2-7 Troubleshooting "STEP 2" \(Check the Unit When Battery Failure Occurs\) \(p.21\)](#)

2-10 Troubleshooting "STEP 5" (Check Each Sensor of Battery)

WARNING

- Perform troubleshooting in safe, clear surroundings. The unit may run unexpectedly.

NOTICE

- If the unit is defective, it may also damage the new battery when the battery is replaced with a new one.

Before replacing the battery, perform flow **STEP 2** to check the unit for problems other than the battery.

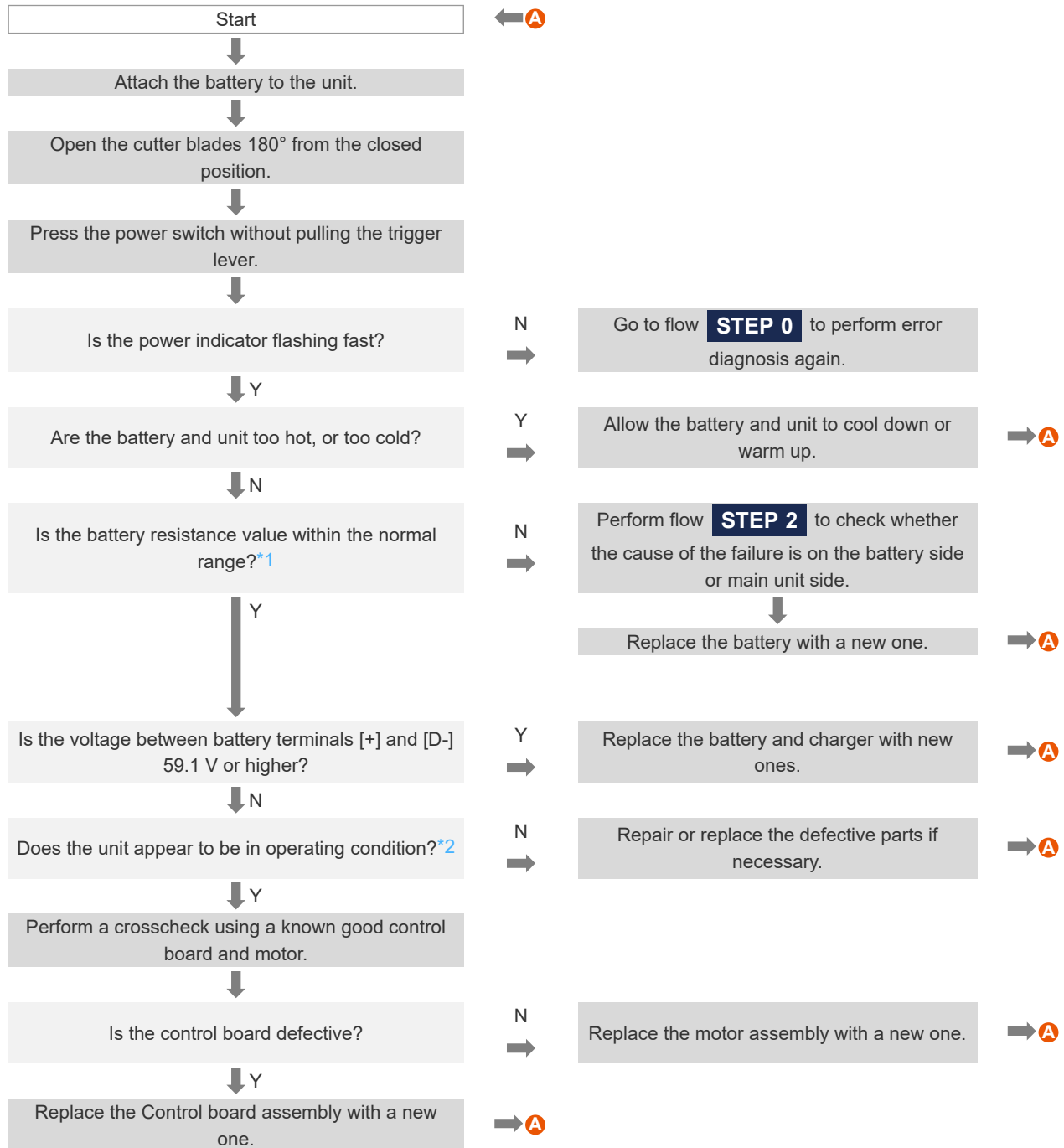

Remark

Y : Yes
N : No

*1 The resistance between battery terminals [T] and [C-] and between battery terminals [T] and [D-] should be from 2.1 kΩ or 78.0 kΩ.

*2 Inspect the unit for the following:

- Each connector is connected securely.
- Each wire is connected to each connector securely.
- All the wires are intact.
- There are no short circuits.
- No conductive substances, such as water and metal pieces, are adhered to the control board .

Related Topics

- [3-8 Inspect the Battery Temperature Sensor \(p.35\)](#)
- [3-6 Inspect the Battery Voltage \(p.34\)](#)
- [4-7 Remove the Control Board Assembly \(p.42\)](#)
- [4-8 Attach the Control Board Assembly \(p.42\)](#)
- [4-5 Remove the Motor Assembly \(p.40\)](#)
- [4-6 Attach the Motor Assembly \(p.41\)](#)
- [2-5 Troubleshooting "STEP 0" \(Error Diagnosis\) \(p.18\)](#)
- [2-7 Troubleshooting "STEP 2" \(Check the Unit When Battery Failure Occurs\) \(p.21\)](#)

2-11 Troubleshooting "STEP 6" (Check the Overload)

⚠ WARNING

- Perform troubleshooting in safe, clear surroundings. The unit may run unexpectedly.

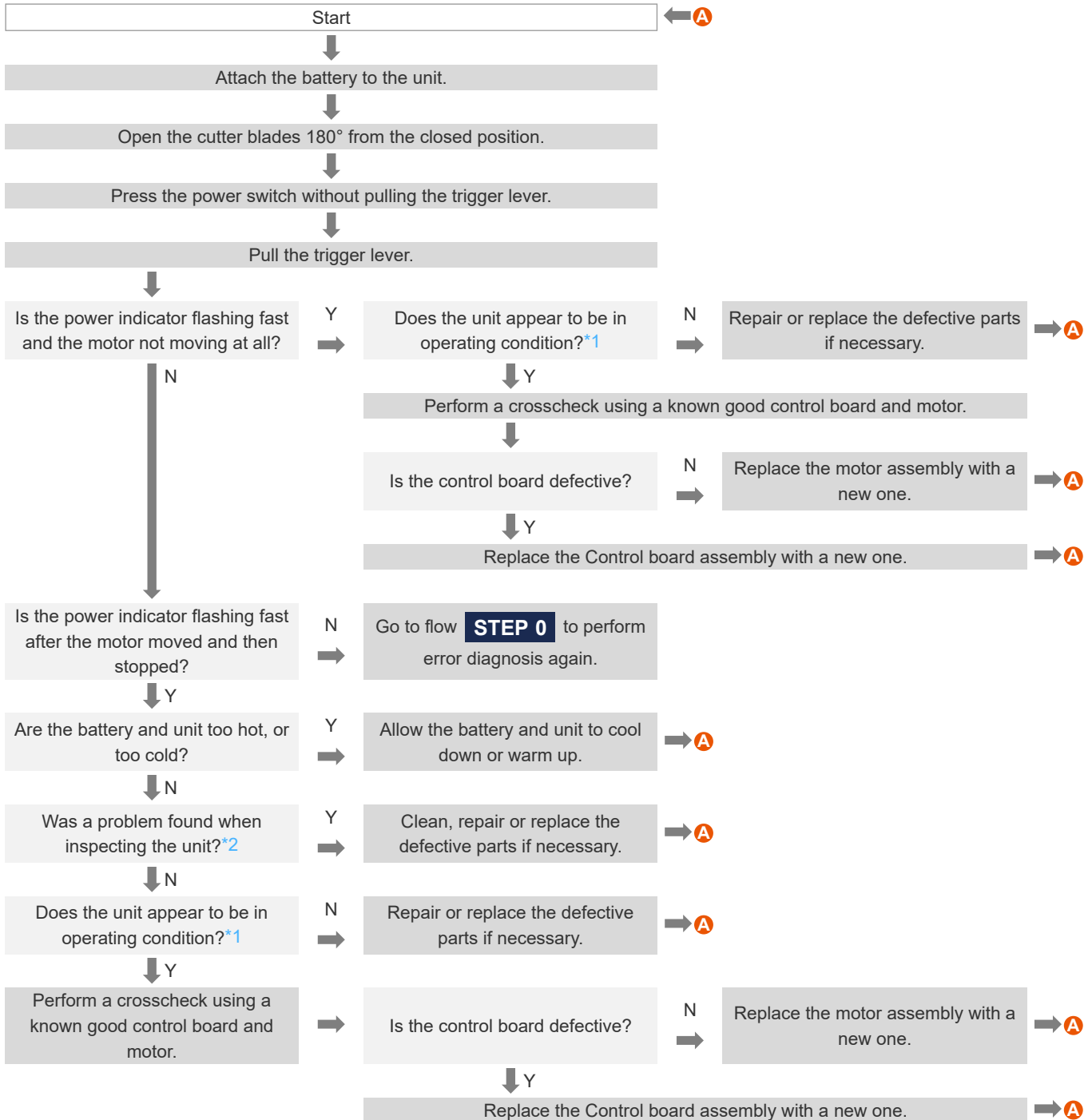

Remark

Y : Yes
 N : No

- *1 Inspect the unit for the following:
- Each connector is connected securely.
 - Each wire is connected to each connector securely.
 - All the wires are intact.
 - There are no short circuits.
- *2 Inspect the unit for the following problems:
- Blade clogged with grass or other objects
 - Blade stuck with tar or rust
 - Non-recommended blade used
 - Blade bent or damaged
 - Cutter clearance too tight
 - Trouble in the drive system

Related Topics

- [4-7 Remove the Control Board Assembly \(p.42\)](#)
- [4-8 Attach the Control Board Assembly \(p.42\)](#)
- [4-5 Remove the Motor Assembly \(p.40\)](#)
- [4-6 Attach the Motor Assembly \(p.41\)](#)
- [2-5 Troubleshooting "STEP 0" \(Error Diagnosis\) \(p.18\)](#)

2-12 Troubleshooting "STEP 7" (Check Other Failures)

⚠ WARNING

- Perform troubleshooting in safe, clear surroundings. The unit may run unexpectedly.

Flow STEP 7 (1)

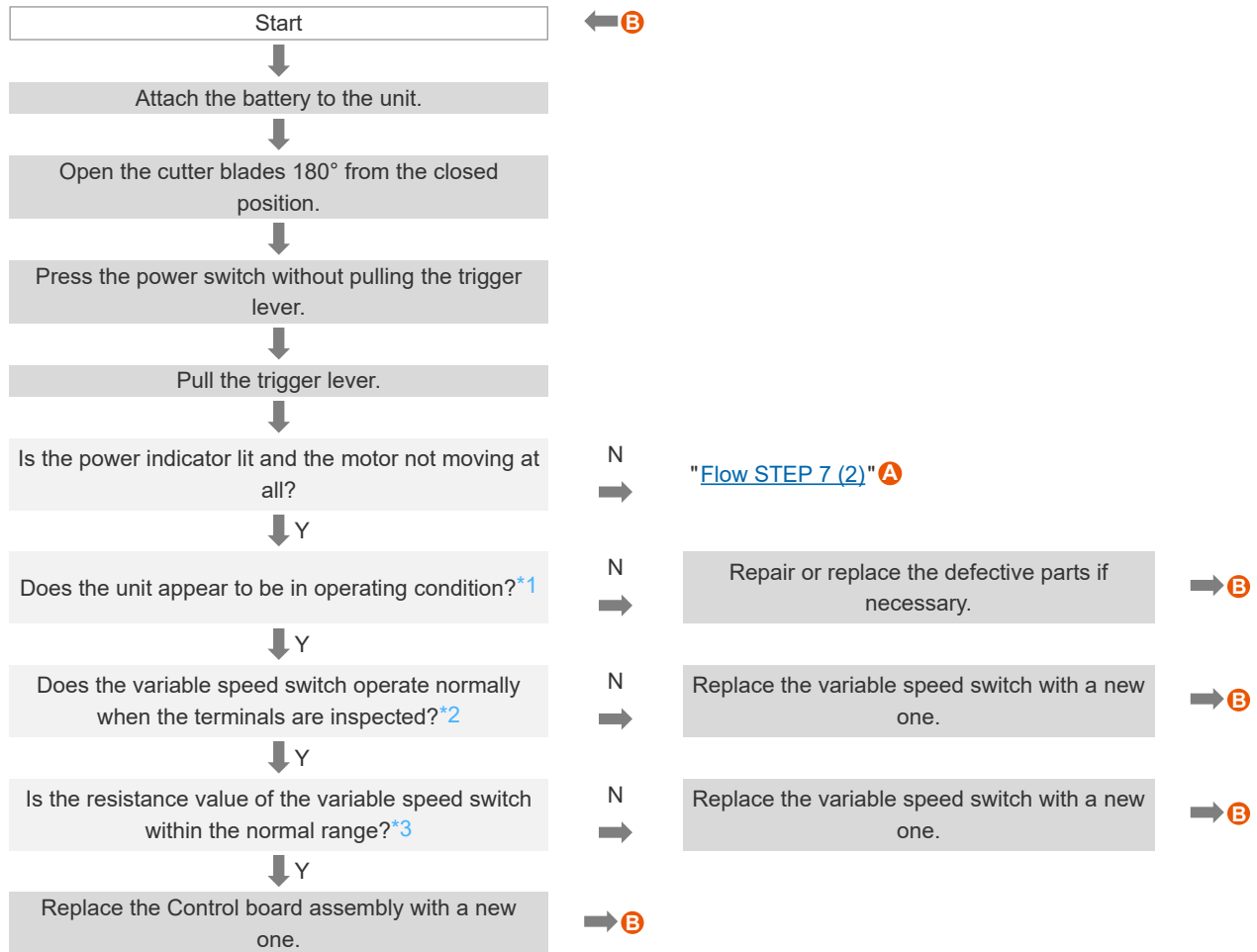

Remark

Y : Yes
N : No

*1 Inspect the unit for the following:

- Each connector is connected securely.
- Each wire is connected to each connector securely.
- All the wires are intact.
- There are no short circuits.

*2 Inspect the terminals of the variable speed switch for the following operation.

- When the switch is pressed : An electric current flows between terminals [1] and [4].
- When the switch is not pressed : No electric current flows between terminals [1] and [4].

- *3 Inspect whether the resistance value between terminals [1] and [2] of the variable speed switch is within the following range.
- When the switch is pressed : 100 Ω or lower
 - When the switch is not pressed : Between 70 kΩ and 130 kΩ

Flow STEP 7 (2)



Remark

Y : Yes
N : No

- *4 Inspect the unit for the following problems:
- Blade clogged with grass or other objects
 - Blade stuck with tar or rust
 - Non-recommended blade used
 - Blade bent or damaged
 - Cutter clearance too tight
 - Trouble in the drive system

*5 Inspect the unit for the following:

- Each connector is connected securely.
- Each wire is connected to each connector securely.
- All the wires are intact.
- There are no short circuits.

Related Topics

- [4-7 Remove the Control Board Assembly \(p.42\)](#)
- [4-8 Attach the Control Board Assembly \(p.42\)](#)
- [4-5 Remove the Motor Assembly \(p.40\)](#)
- [4-6 Attach the Motor Assembly \(p.41\)](#)
- [2-5 Troubleshooting "STEP 0" \(Error Diagnosis\) \(p.18\)](#)

3. Inspect the Battery and Charger

3-1 Battery Components

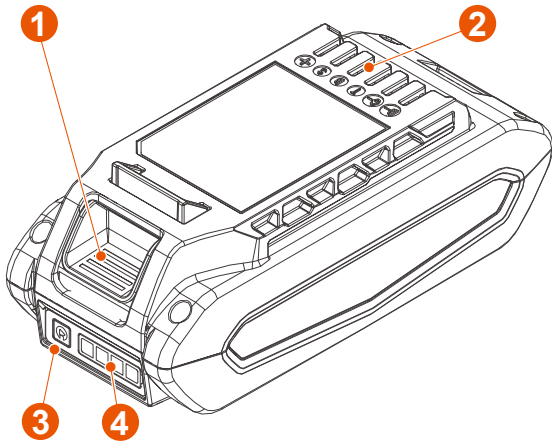

- 1 Battery pack latch
- 2 Battery terminal
- 3 Battery charge status button
- 4 LED charge level indicators

3-2 Charger Components

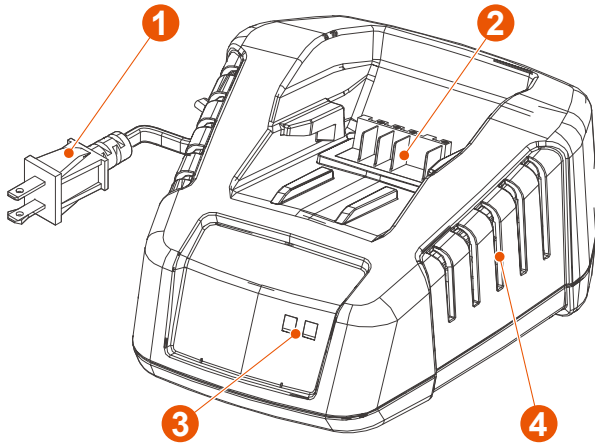

- 1 Power cord
- 2 Battery terminal
- 3 Charging status indicator
- 4 Ventilation holes

3-3 Cautions for Using Battery and Charger

CAUTION

- Do not open or modify the battery. Do not use a battery that is damaged or modified.

Damaged or modified batteries may result in electric shock, fire, explosion or injury.

NOTICE

- Charge the battery in an environment where ambient temperature is within 5°C to 40°C (41°F to 104°F).
- The battery capacity may decrease due to repeated charging and discharging.

When the battery has been charged 500 times, its capacity will have decreased to about 60%, but this is not a problem. If capacity is significantly reduced, replace the battery.

3-4 LED Charge Level Indicator

To light up the LED charge level indicator, press the battery charge status button of the battery. The LED charge level indicator lights up according to the remaining battery charge.

- ▶ : 80% to 100%
- ▶ : 55% to 80%
- ▶ : 25% to 55%
- ▶ : 0% to 25%
- ▶ : 0%

Related Topics

- [3-1 Battery Components \(p.33\)](#)

3-5 Charging Status Indicator

The charging status indicator shows the current battery status. The charging status indicator lights up or flashes when the battery is inserted into the charger.

 (Flashing in green)
The battery is being charged.

 (Green light is on)
The battery is fully charged. Remove the battery from the charger.

 (Flashing in red)
The battery or the charger is defective or there is a bad connection between the battery and the charger.

 (Red light is on)
The battery is too hot or too cold.

Related Topics

➤ [3-2 Charger Components \(p.33\)](#)

3-6 Inspect the Battery Voltage

Prerequisites

- The ambient temperature should be in the range of 0 to 40°C (32°F to 104°F).
For correct measurement, check the ambient temperature in advance.
- Tools required:
 - Multimeter

Procedure

1. **Charge the battery.**
2. **Measure the voltage between battery terminals [D-] and [+] with a multimeter.**
The voltage should be from 55 V to 59 V.

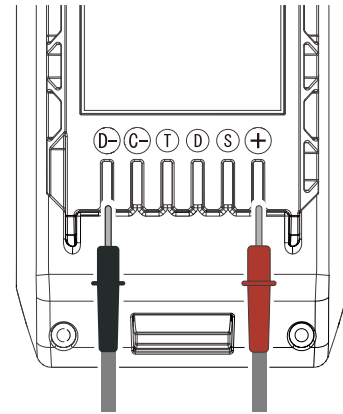

3. **If the voltage is not within the normal range (55 V to 59 V), replace the battery or charger with a new one, depending on the voltage.**

NOTICE

- If the unit is defective, it may also damage the new battery when the battery is replaced with a new one.
Before replacing the battery, perform flow **STEP 2** to check the unit for problems other than the battery.

Lower than 55 V

The battery is defective. Replace the battery with a new one.

59.1 V or higher

The battery has been overcharged due to malfunction of the charger and battery. Replace both the battery and the charger with new ones.

⚠ CAUTION

- Do not use an overcharged battery. It may cause explosion or fire.

Related Topics

- [2-7 Troubleshooting "STEP 2" \(Check the Unit When Battery Failure Occurs\) \(p.21\)](#)
- [3-1 Battery Components \(p.33\)](#)
- [3-2 Charger Components \(p.33\)](#)

3-7 Inspect for Damage from Over-Discharging

Prerequisites

- The ambient temperature should be in the range of 0 to 40°C (32°F to 104°F).
For correct measurement, check the ambient temperature in advance.
- Tools required:
 - Multimeter

Procedure

1. Charge the battery.
2. Measure the resistance between battery terminals [D-] and [D] with a multimeter.

The resistance should be within the $10\text{k}\Omega \pm 2\text{k}\Omega$. Usually, it is about 10 k Ω .

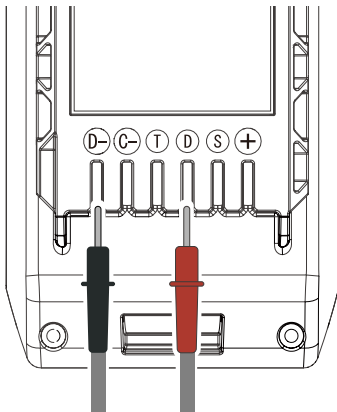

3. If the resistance is outside the $10\text{k}\Omega \pm 2\text{k}\Omega$, replace the battery with a new one.

If the resistance is greater than 0.95 M Ω , the battery is over-discharged.

NOTICE

- If the unit is defective, it may also damage the new battery when the battery is replaced with a new one.

Before replacing the battery, perform flow **STEP 2** to check the unit for problems other than the battery.

CAUTION

- Do not use an over-discharged battery. It may cause explosion or fire.

Related Topics

- [2-7 Troubleshooting "STEP 2" \(Check the Unit When Battery Failure Occurs\) \(p.21\)](#)
- [3-1 Battery Components \(p.33\)](#)
- [3-2 Charger Components \(p.33\)](#)

3-8 Inspect the Battery Temperature Sensor

Prerequisites

- The ambient temperature should be in the range of 0 to 40°C (32°F to 104°F).
For correct measurement, check the ambient temperature in advance.
- Tools required:
 - Multimeter

Procedure

1. Measure the resistance between battery terminals [C-] and [T] and between battery terminals [D-] and [T] with a multimeter.

Both resistance should be within the 2.1 k Ω to 78.0 k Ω .

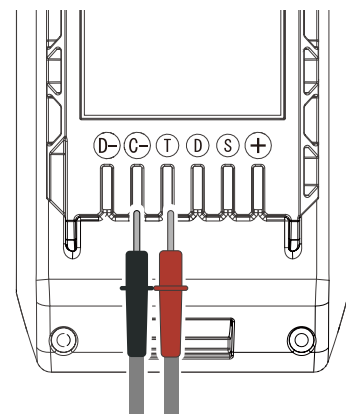

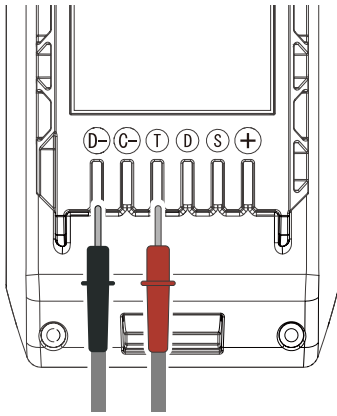

2. If the resistance is outside the 2.1 k Ω to 78.0 k Ω , replace the battery with a new one.

The temperature sensor is damaged.

NOTICE

- If the unit is defective, it may also damage the new battery when the battery is replaced with a new one.

Before replacing the battery, perform flow

STEP 2 to check the unit for problems other than the battery.

Related Topics

- [2-7 Troubleshooting "STEP 2" \(Check the Unit When Battery Failure Occurs\) \(p.21\)](#)
- [3-1 Battery Components \(p.33\)](#)

4. Disassemble/Assemble the Motor and Control Board Assembly

4-1 Motor and Control Board Assembly Components

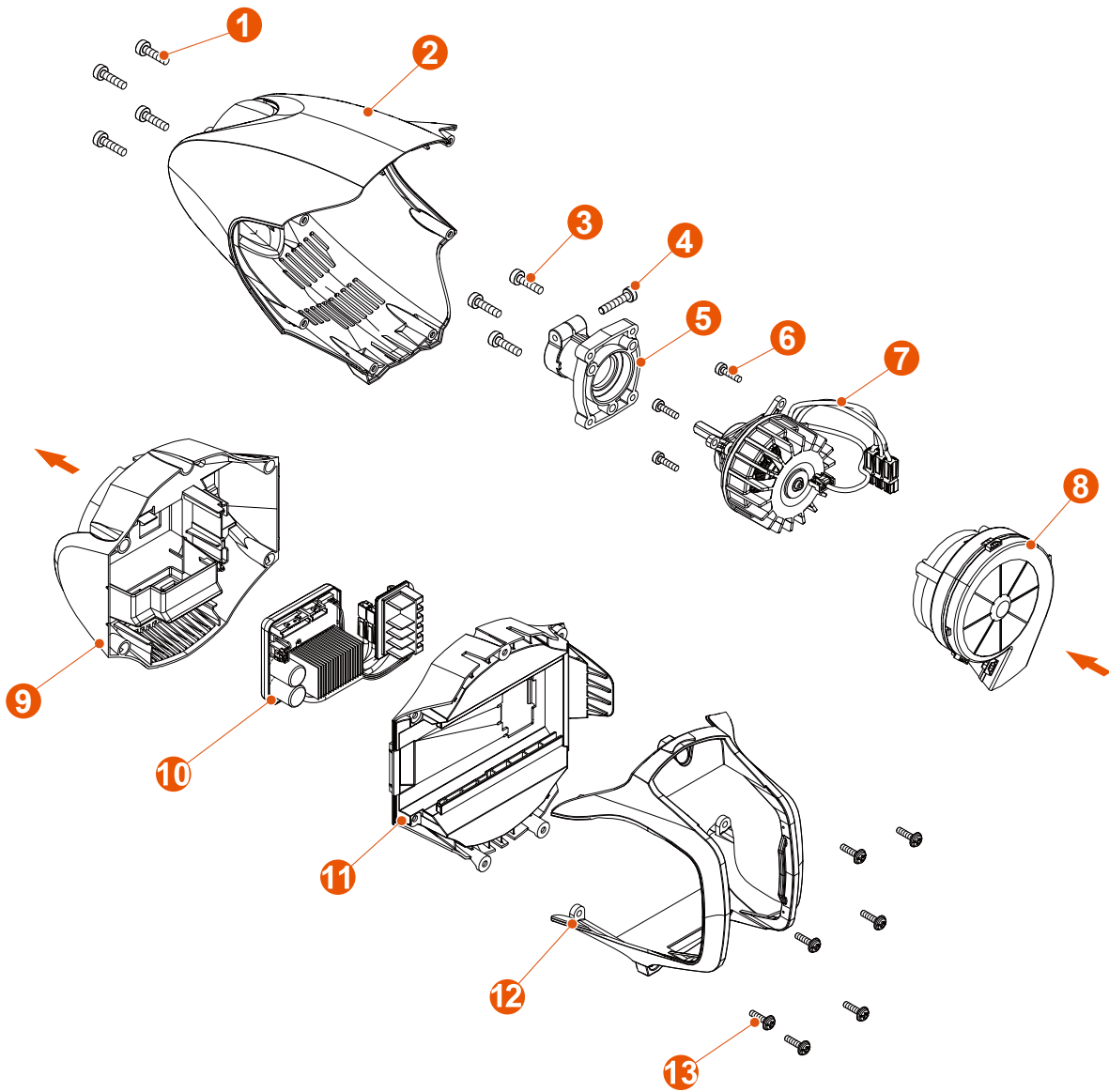

- 1 Torx bolt (M5)
- 2 Motor cover
- 3 Torx bolt (M5)
- 4 Torx bolt (M5)
- 5 Main pipe fixture
- 6 Torx bolt (M5)
- 7 Motor assembly
- 8 Fan case
- 9 Air duct
- 10 Control board assembly
- 11 Battery holder
- 12 Battery cover
- 13 Torx bolt (M5)

4-2 Remove/Attach the Battery Holder

When reinstalling the removed parts, do so in the reverse order from that indicated below.

Prerequisites

- Tools required:
 - Torx wrench (T27)

Procedure

1. Remove the 7 Torx bolts **A**.
2. Remove the battery cover **B**.

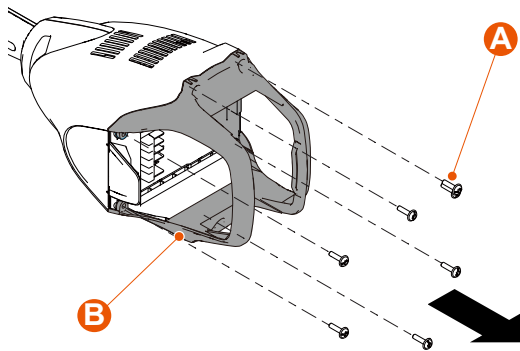

3. Remove the battery holder.

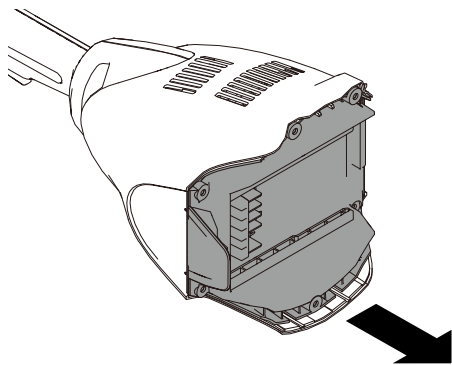

4. Remove the battery terminal **C** from the battery holder.

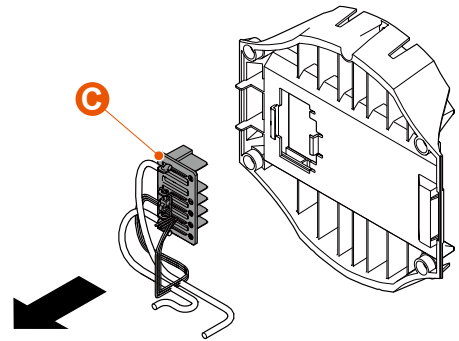

5. Inspect the removed parts.
If any deformation, damage, or wear is found, replace the parts with new ones.

Related Topics

- [4-1 Motor and Control Board Assembly Components \(p.37\)](#)

4-3 Remove the Motor Cover

Prerequisites

- Remove the following parts.
 - (1) Main pipe
 - (2) Battery holder
- Tools required:
 - Torx wrench (T27)

Procedure

1. Remove the 4 Torx bolts **A**.

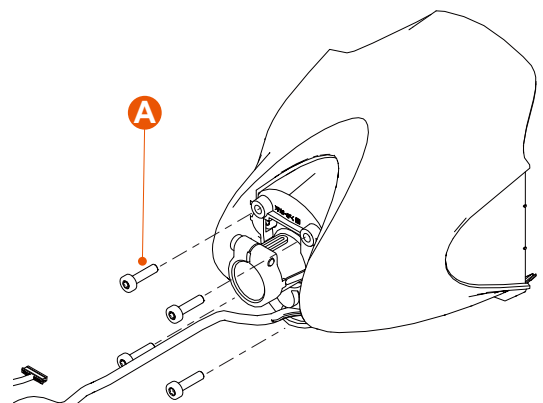

2. Make sure that the Torx bolt **B** is tightened.

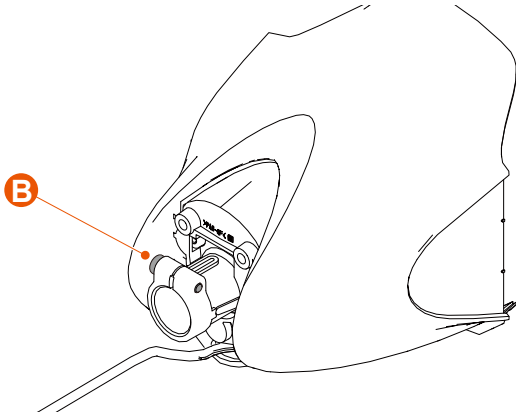

3. Disconnect the 10-pin connector **C** from the control board.

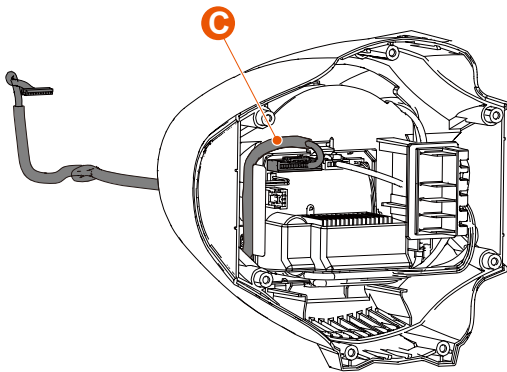

4. Remove the tabs **D** of the motor cover from the main pipe fixture **E**.

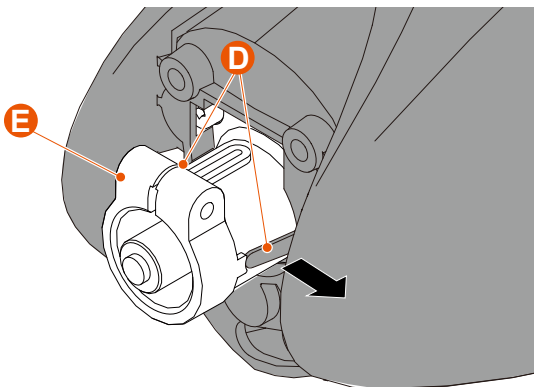

5. Remove the following parts.

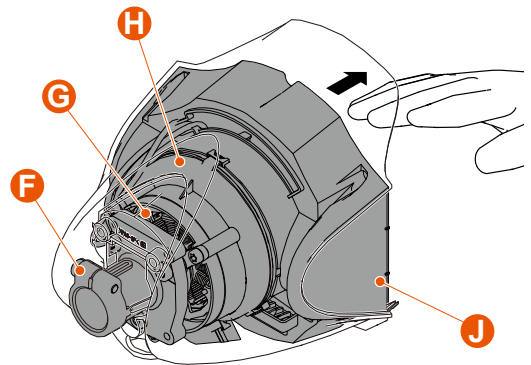

- Main pipe fixture **F**
- Motor assembly **G**
- Fan case **H**
- Air duct **J**

6. Inspect the removed parts.

If any deformation, damage, or wear is found, replace the parts with new ones.

Related Topics

- [4-1 Motor and Control Board Assembly Components \(p.37\)](#)
- [4-4 Attach the Motor Cover \(p.39\)](#)
- [9-2 Remove/Attach the Main Pipe and Flexible Shaft \(p.74\)](#)
- [4-2 Remove/Attach the Battery Holder \(p.38\)](#)

4-4 Attach the Motor Cover

Prerequisites

- Tools required:
 - Torx wrench (T27)
 - Battery terminal grease (Permatex PTX81150 or equivalent)

Procedure

1. Pass the 10-pin connector **A** of the power switch through the hole in the motor cover.

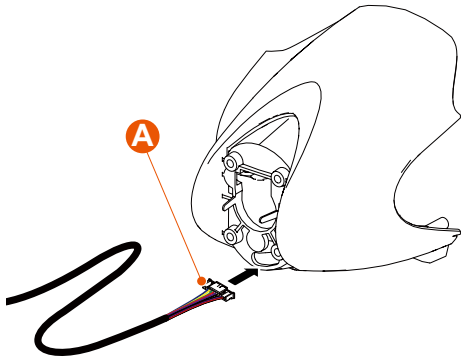

2. Pass the 2-pin connector **B** of the control board **C** through the hole in the motor cover.

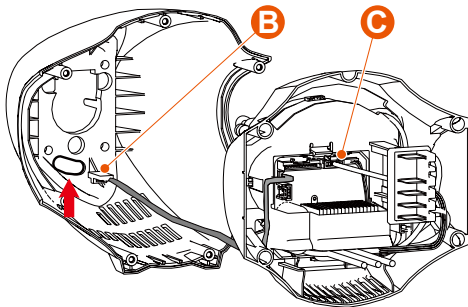

3. Pass the 10-pin connector **A** of the power switch through the hole in the air duct **D**.

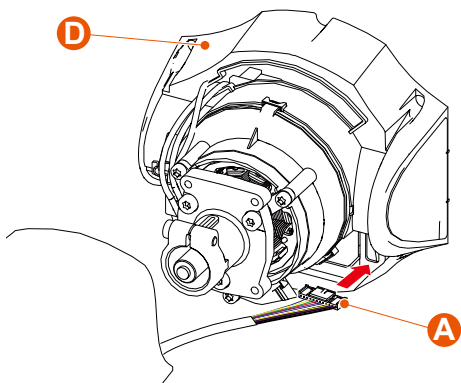

4. Apply the battery terminal grease (Permatex PTX81150 or equivalent) **E** in the connector **F** of the control board.

5. Connect the 10-pin connector **A** of the power switch to the control board **C**.

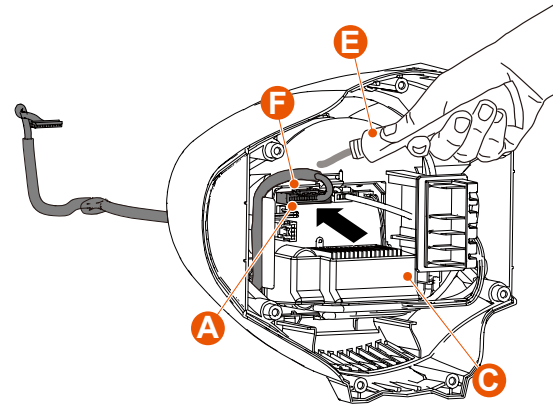

6. Tighten the 4 Torx bolts **G**.

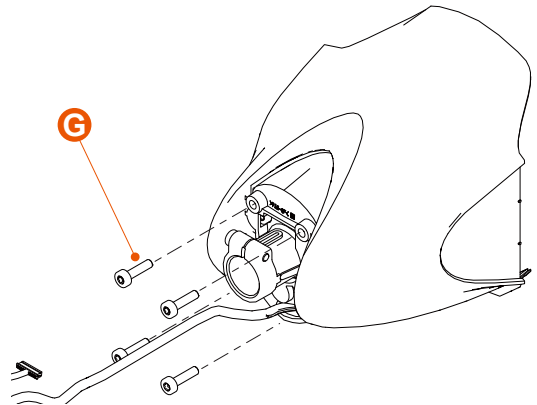

7. Attach the main pipe.

8. Attach the battery holder.

Related Topics

- [4-1 Motor and Control Board Assembly Components \(p.37\)](#)
- [4-3 Remove the Motor Cover \(p.38\)](#)
- [9-2 Remove/Attach the Main Pipe and Flexible Shaft \(p.74\)](#)
- [4-2 Remove/Attach the Battery Holder \(p.38\)](#)

4-5 Remove the Motor Assembly

Prerequisites

- Remove the following parts.
 - (1) Main pipe fixture
- Tools required:
 - Torx wrench (T27)

Procedure

1. Disconnect the 5-pin connector **A** of the motor from the control board.
2. Disconnect the 3-pin connector **B** of the motor and 3-pin connector **C** of the control board.
3. Remove the air duct **D**.

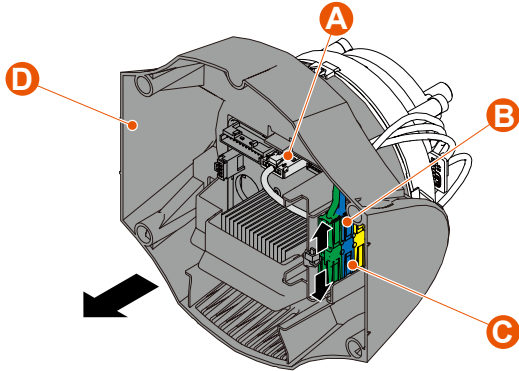

4. Remove the 3 Torx bolts **E**.
5. Remove the fan case **F**.

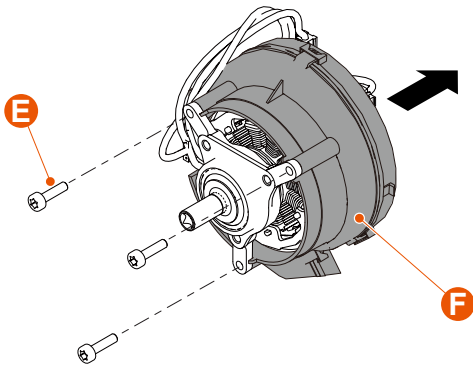

Related Topics

- [4-1 Motor and Control Board Assembly Components \(p.37\)](#)
- [4-6 Attach the Motor Assembly \(p.41\)](#)
- [9-3 Remove/Attach the Main Pipe Fixture \(p.75\)](#)

4-6 Attach the Motor Assembly

Prerequisites

- Tools required:
 - Torx wrench (T27)
 - Battery terminal grease (Permatex PTX81150 or equivalent)

Procedure

1. Attach the fan case **A** to the motor assembly.
2. Tighten the 3 Torx bolts **B**.

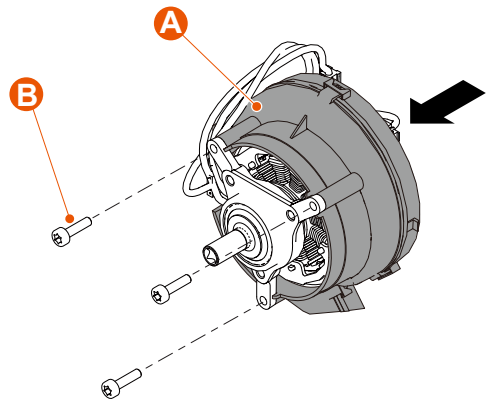

3. Route the wire **C** of the motor through the ribs of the fancase **D** and pass the wire **C** in the hole in the air duct **E**.
4. Pass the wire **F** of the motor in the hole in the air duct **E**.

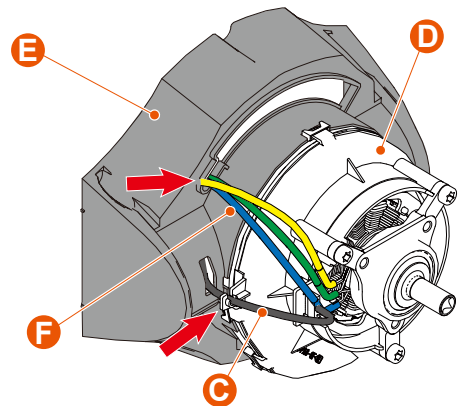

5. Apply the battery terminal grease (Permatex PTX81150 or equivalent) **G** in the connector **H** of the control board.

- Connect the 5-pin connector **J** to the control board **K**.
- Connect the 3-pin connector **L** of the motor and 3-pin connector **M** of the control board **K** and install them into the groove.

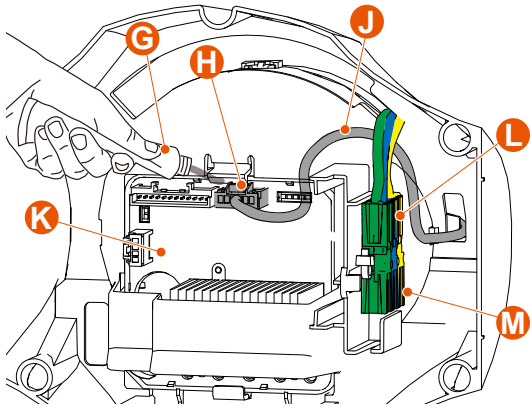
**NOTICE**

Wipe off the battery terminal grease that has been spilled.

- Attach the main pipe fixture.

Related Topics

- [4-1 Motor and Control Board Assembly Components \(p.37\)](#)
- [4-5 Remove the Motor Assembly \(p.40\)](#)
- [9-3 Remove/Attach the Main Pipe Fixture \(p.75\)](#)

4-7 Remove the Control Board Assembly**Prerequisites**

- Remove the following parts.
 - (1) Motor cover

Procedure

- Remove the 5-pin connector **A** of the motor from the control board.

- Disconnect the 3-pin connector **B** of the motor and 3-pin connector **C** of the control board.

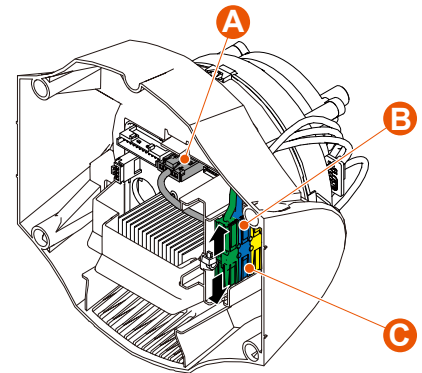

- Remove the control board.

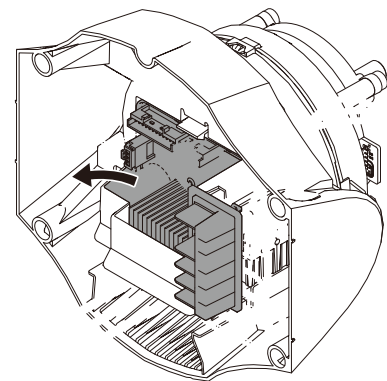

- Inspect the removed parts.

If any deformation, damage, or wear is found, replace the parts with new ones.

Related Topics

- [4-1 Motor and Control Board Assembly Components \(p.37\)](#)
- [4-8 Attach the Control Board Assembly \(p.42\)](#)
- [4-3 Remove the Motor Cover \(p.38\)](#)

4-8 Attach the Control Board Assembly**Prerequisites**

- Tools required:
 - Battery terminal grease (Permatex PTX81150 or equivalent)

Procedure

1. Pass the battery terminal **A** and 3-pin connector **B** of the control board in the hole of the air duct **C**.
2. Attach the control board assembly to the air duct **C**.

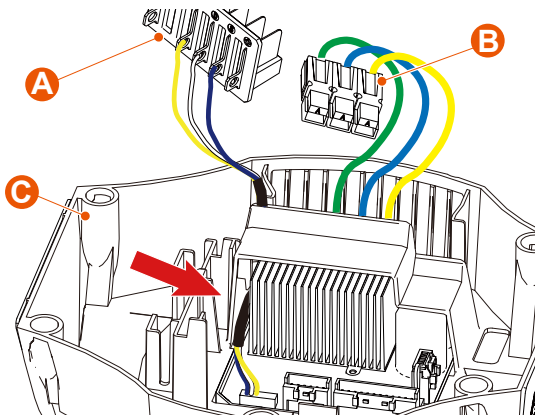

3. Apply the battery terminal grease (Permatex PTX81150 or equivalent) **D** in the connector **E** of the control board.
4. Connect the 5-pin connector **F** to the control board.
5. Connect the 3-pin connector **G** of the motor and 3-pin connector **H** of the control board and install them into the groove.

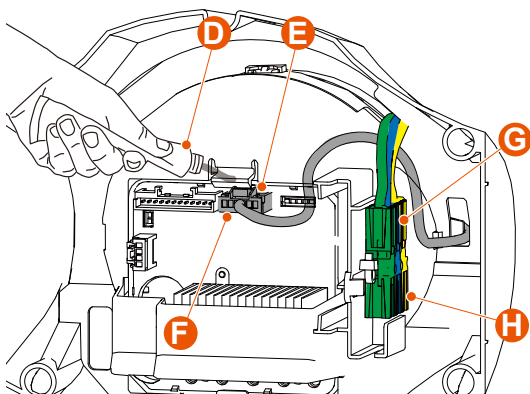

NOTICE

Wipe off the battery terminal grease that has been spilled.

6. Pass the wire **J** of the interlock switch through the hole in the air duct **C**.

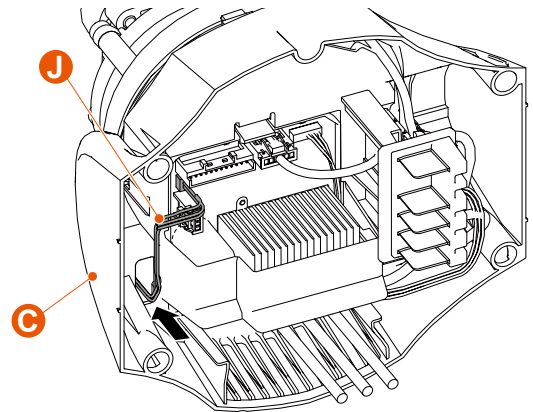

7. Attach the motor cover.

Related Topics

- [4-1 Motor and Control Board Assembly Components \(p.37\)](#)
- [4-3 Remove the Motor Cover \(p.38\)](#)

5. Disassemble/Assemble the Switch and Trigger

5-1 Switch and Trigger Components

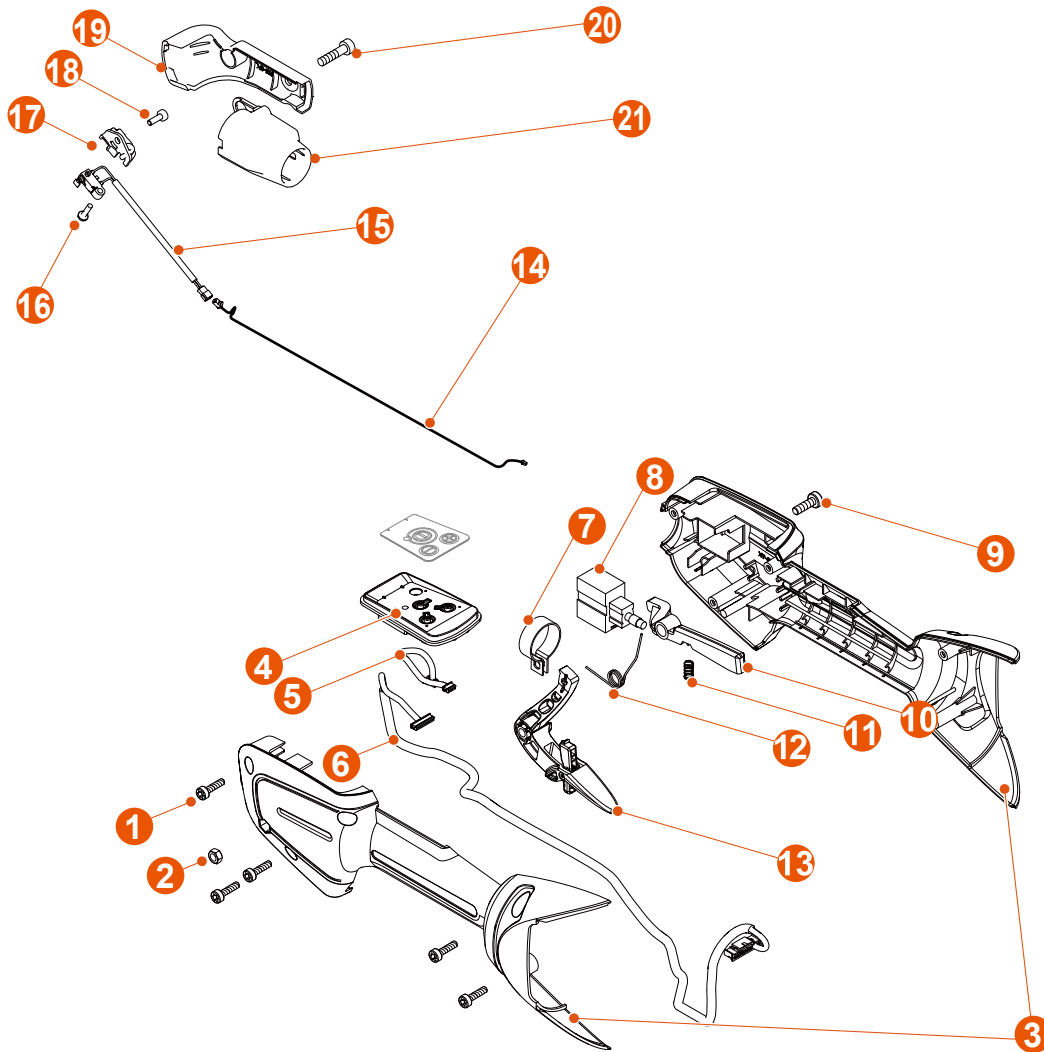

1 Torx bolt(M4)

2 Nut

3 Trigger holder

4 Power switch

5 Wire harness

6 Wire harness

7 Band

8 Variable speed switch

9 Torx bolt(M5)

10 Trigger lockout

11 Coil spring

12 Torsion spring

13 Trigger lever

14 Wire harness

15 Interlock switch

16 Screw

17 Switch stay

18 Torx bolt

19 Gear case lid

20 Torx bolt

21 Boot

5-2 Remove/Attach the Trigger Holder

When reinstalling the removed parts, do so in the reverse order from that indicated below.

Prerequisites

- Tools required:
 - Torx wrench (T27)

Procedure

1. Loosen the Torx bolt **A**.

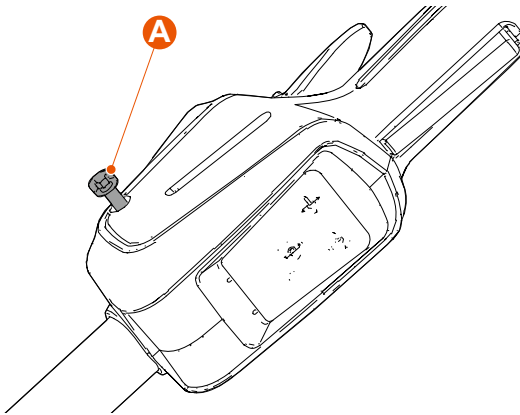

2. Slide the trigger holder in the direction of the arrow.



3. Remove the 5 Torx bolts **C**.

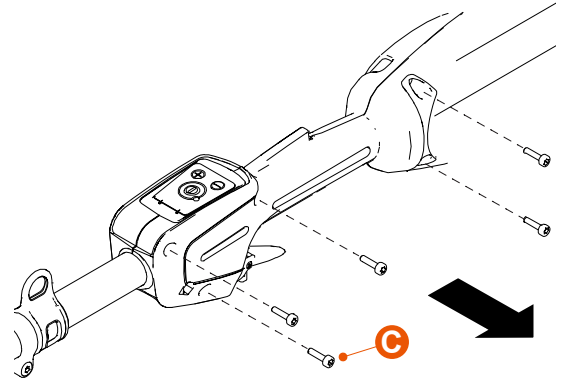

4. Remove the trigger holder half **D**.

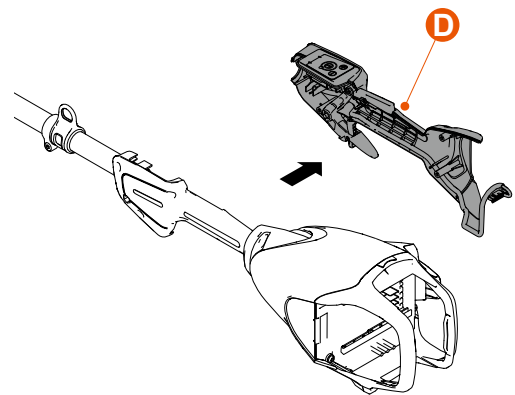

5. Remove the Torx bolt **E** and the nut **F**.

6. Remove the trigger holder half **G**.

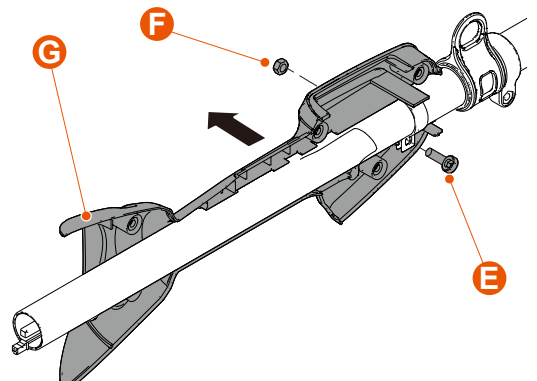

7. Inspect the removed parts.

If any deformation, damage, or wear is found, replace the parts with new ones.

Related Topics

- [5-1 Switch and Trigger Components \(p.44\)](#)

5-3 Remove the Trigger Parts

Prerequisites

- Remove the following parts.
 - Trigger holder

Procedure

- Remove the following parts.

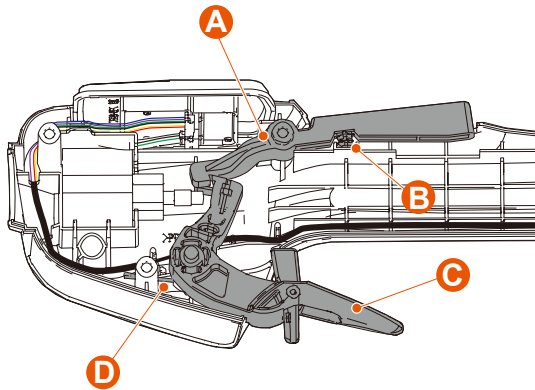

- Trigger lockout **A**
- Coil spring **B**
- Trigger lever **C**
- Torsion spring **D**

- Inspect the removed parts.

If any deformation, damage, or wear is found, replace the parts with new ones.

Related Topics

- [5-1 Switch and Trigger Components \(p.44\)](#)
- [5-4 Attach the Trigger Parts \(p.46\)](#)
- [5-2 Remove/Attach the Trigger Holder \(p.45\)](#)

5-4 Attach the Trigger Parts

Procedure

- Assemble the following parts.

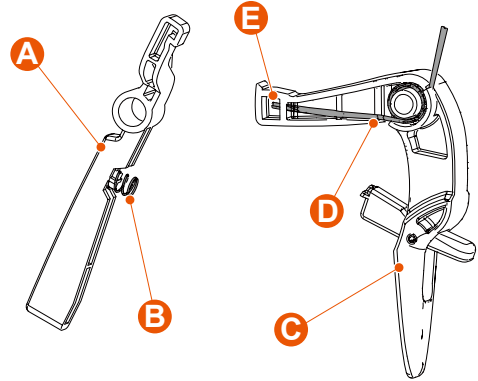

- Trigger lockout **A**
- Coil spring **B**
- Trigger lever **C**
- Torsion spring **D**

NOTICE

Make sure that the longer end of the torsion spring **E** is in the hole in the trigger lever **C**.

- Attach the following parts.

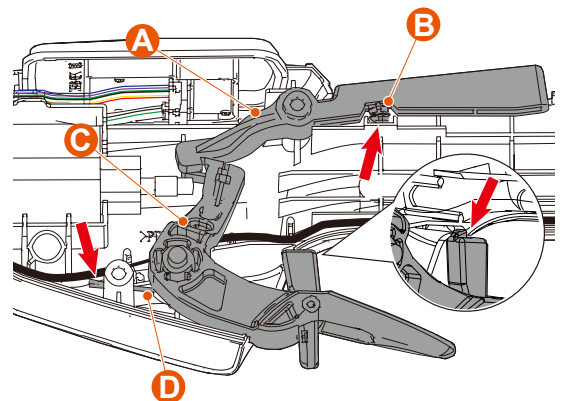

- Trigger lockout **A**
- Coil spring **B**
- Trigger lever **C**
- Torsion spring **D**

NOTICE

Make sure that each part is as follows.

- The coil spring **B** is seated in the groove.
- The shorter end of the torsion spring **D** is caught by the boss of the trigger holder.
- The end of the trigger lever **C** is caught by the rib of the trigger holder.

3. Attach the trigger holder.

Related Topics

- [5-1 Switch and Trigger Components \(p.44\)](#)
- [5-3 Remove the Trigger Parts \(p.46\)](#)
- [5-2 Remove/Attach the Trigger Holder \(p.45\)](#)

5-5 Remove the Power Switch

Prerequisites

- Remove the following parts.
 - (1) Trigger parts

Procedure

1. Remove the power switch from the trigger holder **A**.

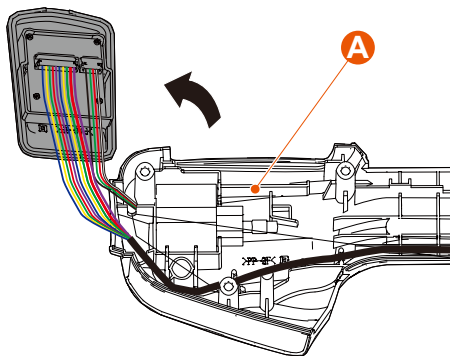

2. Disconnect the 10-pin connector **B** and the 4-pin connector **C** from the power switch.

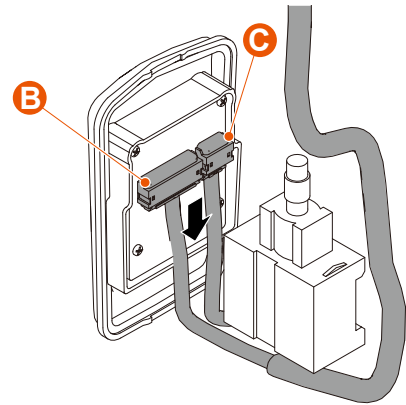

3. Inspect the removed parts.

If any deformation, damage, or wear is found, replace the parts with new ones.

Related Topics

- [5-1 Switch and Trigger Components \(p.44\)](#)
- [5-6 Attach the Power Switch \(p.47\)](#)
- [5-3 Remove the Trigger Parts \(p.46\)](#)

5-6 Attach the Power Switch

Procedure

1. Connect the 10-pin connector **A** and the 4-pin connector **B** to the power switch.

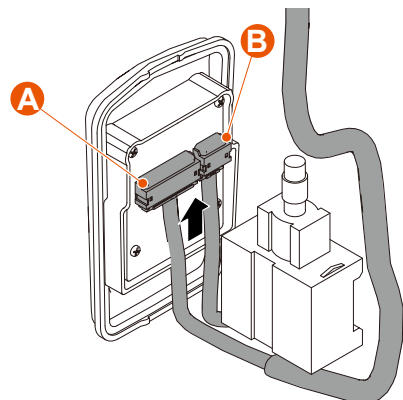

NOTICE

- Make sure that the connector is fully inserted as shown.

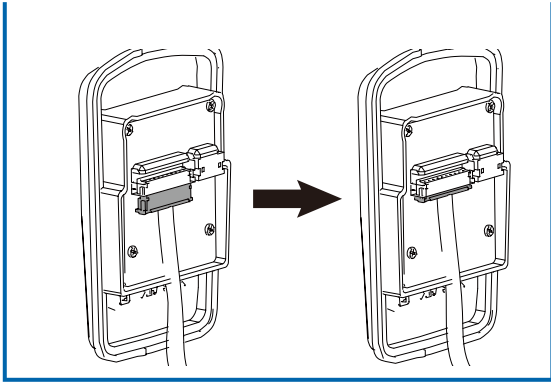

2. Route the wire harness **C** through the ribs of the trigger holder as shown.

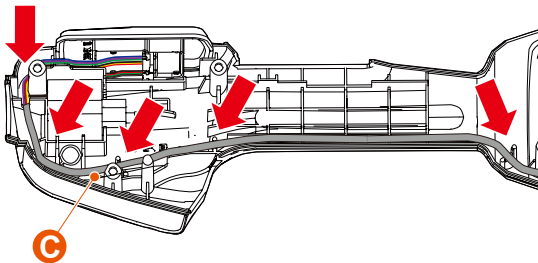

NOTICE

Make sure that the each leads of the wire harness **C** are seated between the power switch and the ribs of the trigger holder as shown.

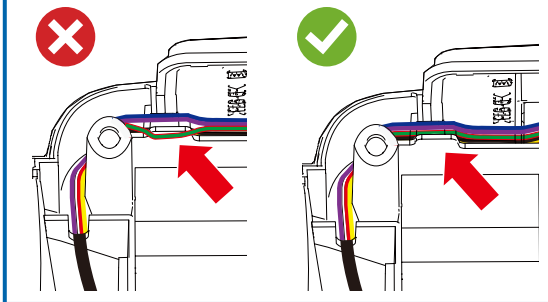

3. Attach the trigger parts.

Related Topics

- [5-1 Switch and Trigger Components \(p.44\)](#)
- [5-5 Remove the Power Switch \(p.47\)](#)
- [5-4 Attach the Trigger Parts \(p.46\)](#)

5-7 Remove/Attach the Variable Speed Switch

When reinstalling the removed parts, do so in the reverse order from that indicated below.

Prerequisites

- Remove the following parts.

- (1) Trigger parts

Procedure

1. Remove the variable speed switch from the trigger holder **A**.

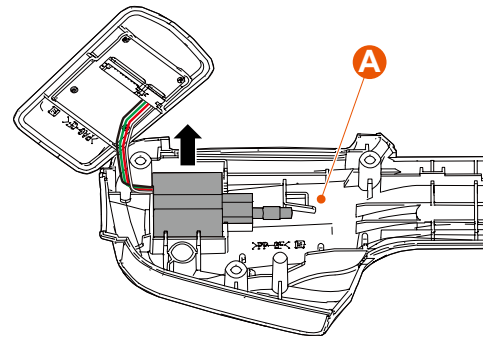

2. Disconnect the 4-pin connector **B** of the wire harness from the power switch **C**.

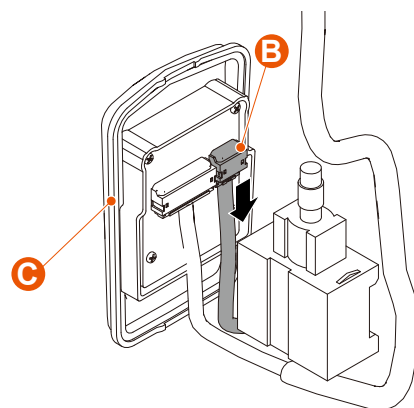

3. Remove the 4-pin connector of the wire harness from the variable speed switch.

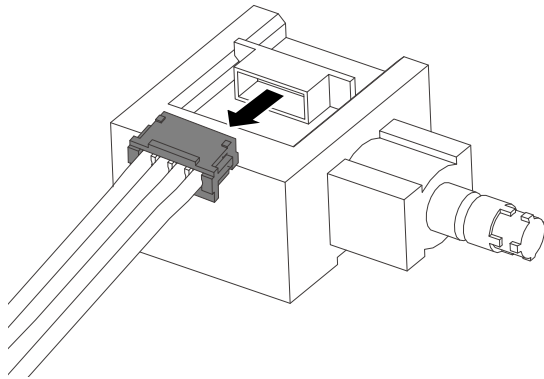

4. Inspect the removed parts.

If any deformation, damage, or wear is found, replace the parts with new ones.

Related Topics

- [5-1 Switch and Trigger Components \(p.44\)](#)
- [5-5 Remove the Power Switch \(p.47\)](#)

5-8 Remove the Interlock Switch Cover

Prerequisites

- Tools required:
 - Torx wrench (T27)

Procedure

1. Remove the Torx bolt **A** and interlock switch cover.

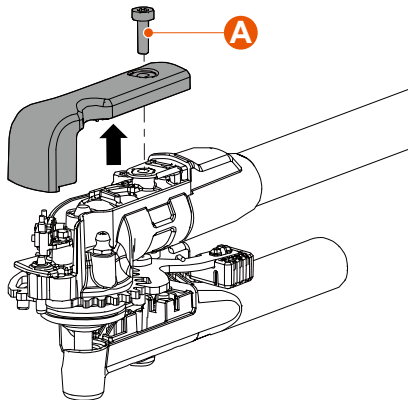

2. Slide the boot **B** in the direction of the arrow.

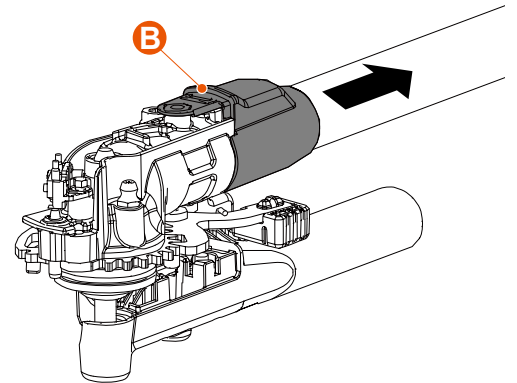

3. Inspect the removed parts.

If any deformation, damage, or wear is found, replace the parts with new ones.

Related Topics

- [5-1 Switch and Trigger Components \(p.44\)](#)
- [5-9 Attach the Interlock Switch Cover \(p.49\)](#)

5-9 Attach the Interlock Switch Cover

Prerequisites

- Required tools:
 - Torx wrench (T27)

Procedure

1. Slide and attach the boot **A** in the direction of the arrow.

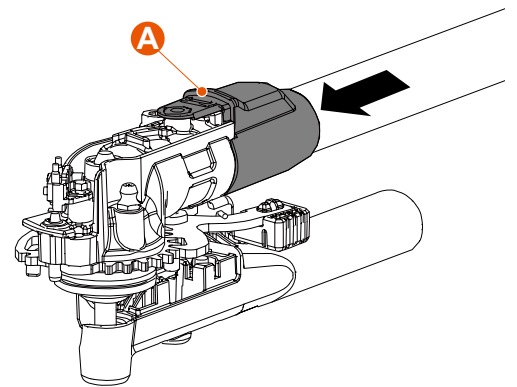

- Hook the interlock switch cover over the rib of the gear case **B** and attach the interlock switch cover.

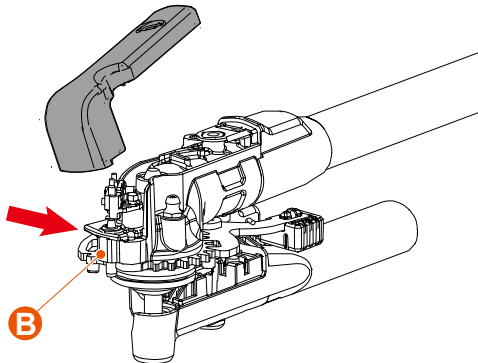

- Tighten the Torx bolt **C**.

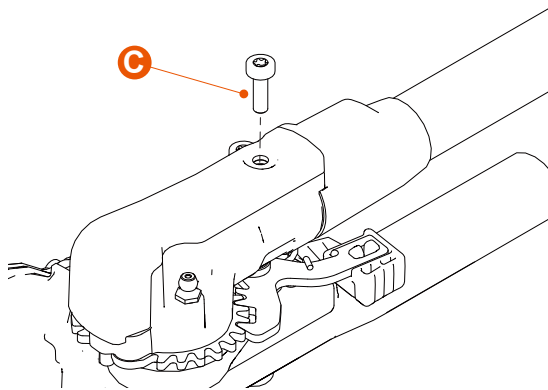

Related Topics

- [5-1 Switch and Trigger Components \(p.44\)](#)
- [5-8 Remove the Interlock Switch Cover \(p.49\)](#)

5-10 Remove the Interlock Switch

Prerequisites

- Remove the following parts.
 - (1) Interlock switch cover
 - (2) Trigger holder
- Tools required:
 - Torx wrench (T27)
 - Phillips screwdriver
 - Tape for wrapping connector

Procedure

- Disconnect the connector **A** of the interlock switch.

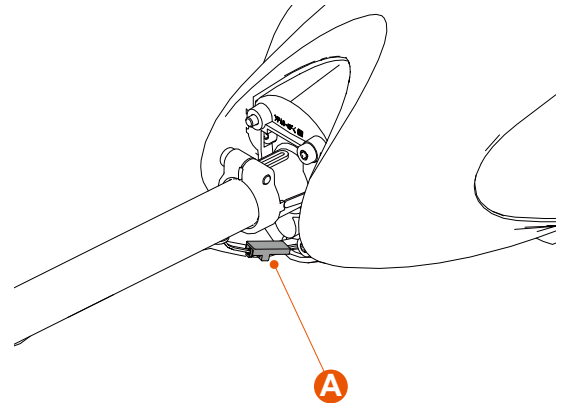

- Disconnect the connector **B** of the interlock switch.

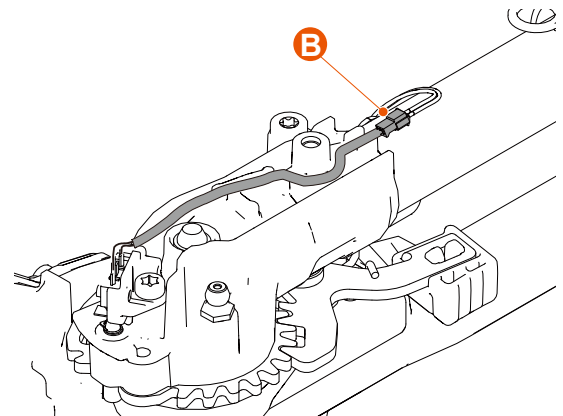

- Remove the Torx bolt **B** and interlock switch.

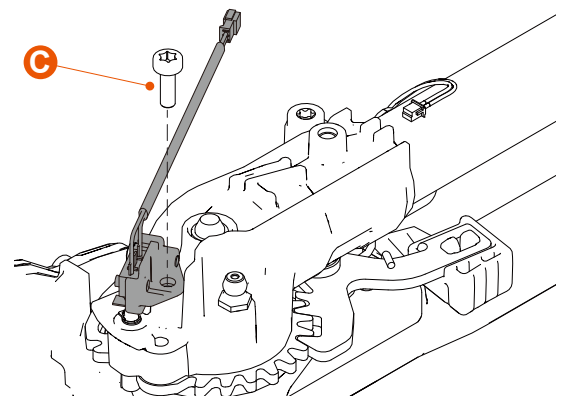

- Remove the screw **D** and the switch stay **E** from the interlock switch.

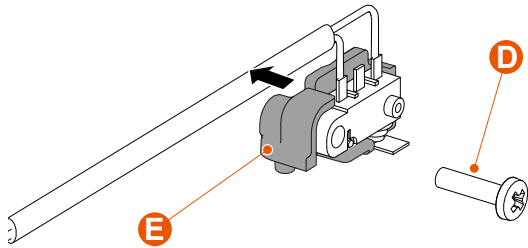

- Wrap tape **F** around the smaller connector **G** of the wire harness **J** to prevent grease from entering into the smaller connector **G**.
- Insert the smaller connector **G** into the hole **H** in the main pipe.

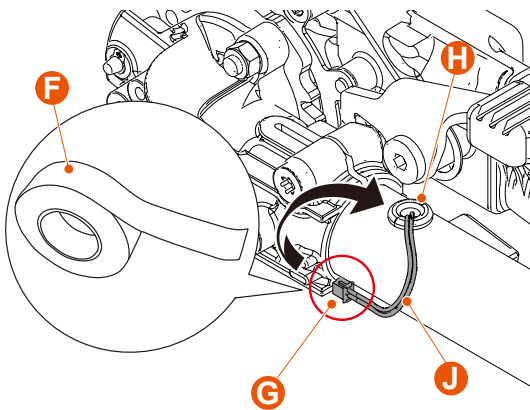

- Pull out the wire harness **J** from the hole in the main pipe on the motor side.

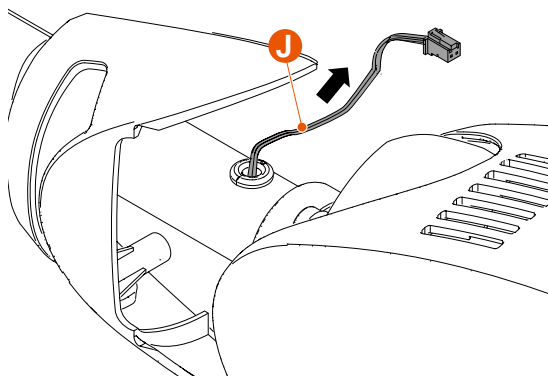

- Inspect the removed parts.

If any deformation, damage, or wear is found, replace the parts with new ones.

Related Topics

- [5-1 Switch and Trigger Components \(p.44\)](#)
- [5-11 Attach the Interlock Switch \(p.51\)](#)
- [5-8 Remove the Interlock Switch Cover \(p.49\)](#)
- [5-2 Remove/Attach the Trigger Holder \(p.45\)](#)
- [10-5 Inspect the Interlock Switch \(p.80\)](#)

5-11 Attach the Interlock Switch

Prerequisites

- Tools required:
 - Wire (Length is longer than main pipe)
 - Tape for wrapping connector
 - Torx wrench (T27)
 - Phillips screwdriver
 - Thread locking sealant(ThreeBond #1324N or equivalent)

Procedure

- Wrap tape **A** around the smaller connector **B** of the wire harness **C** to prevent grease from entering into the smaller connector **B**.

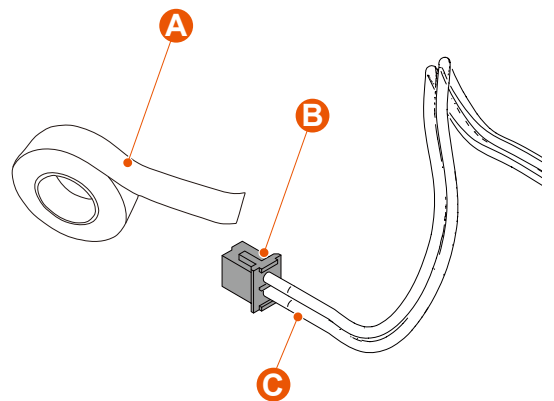

2. Wind the wire **D** around the wire harness **C**.

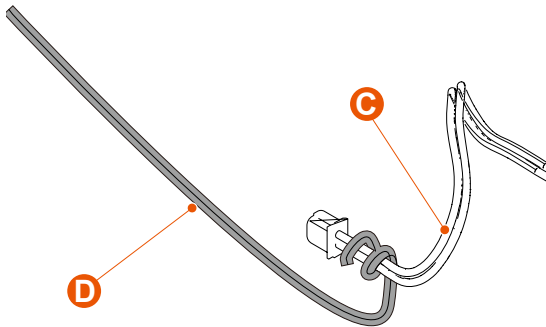

NOTICE

Take care not to damage the wire harness **C**.

3. Remove the grommet **E** on the motor side.

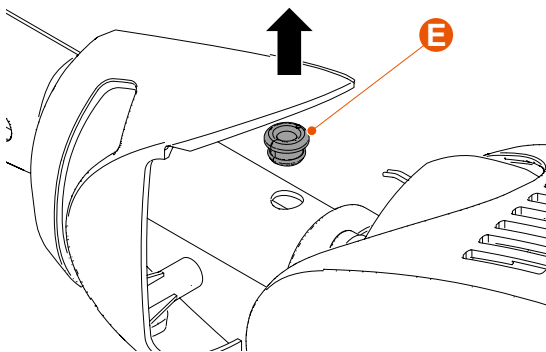

4. Insert the wire **D** and the wire harness **C** into the hole **F** in the main pipe on the motor side.

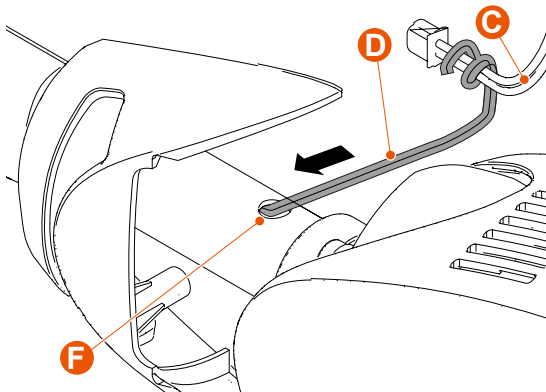

5. Attach the grommet **E** to prevent damage to the wire harness **C**.

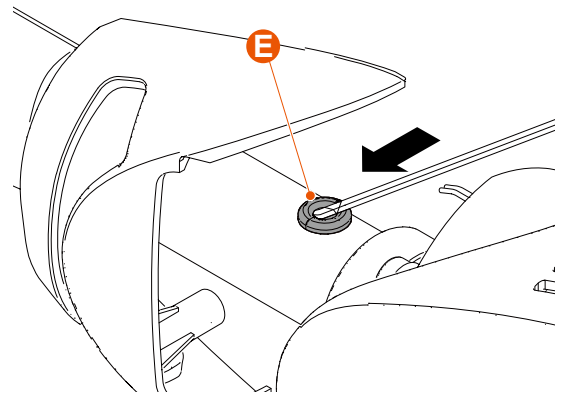

6. Pull out the wire **D** and the wire harness **C** from the hole in the main pipe on the gear case side.

7. Attach the grommet **G** when the smaller connector **B** is pulled out to prevent damage to the wire harness **C**.

8. Remove the tape from the smaller connector **B**.

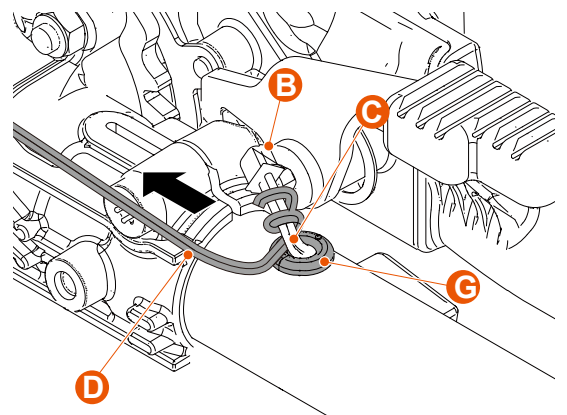

9. Assemble the interlock switch and the switch stay **H** with the screw **J**.

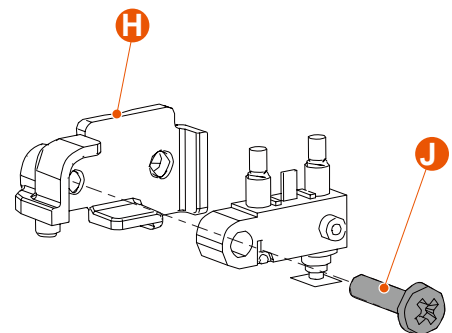

10. Apply thread locking sealant (ThreeBond #1324N or equivalent) to the hole **K** of the gear case.
11. Attach the interlock switch with the Torx bolt **L**.

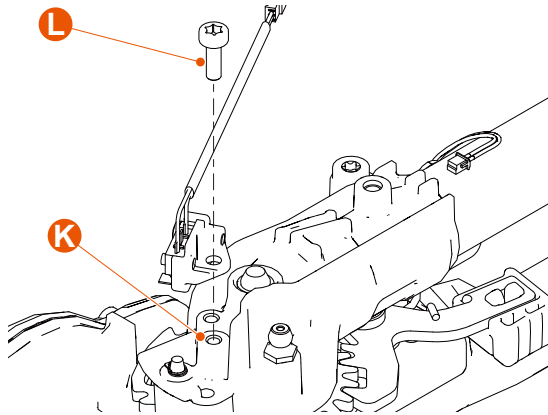

12. Pass the wire **M** of the interlock switch through the ribs of the gear case.
13. Connect the connector **N** of the interlock switch to the smaller connector **B**.

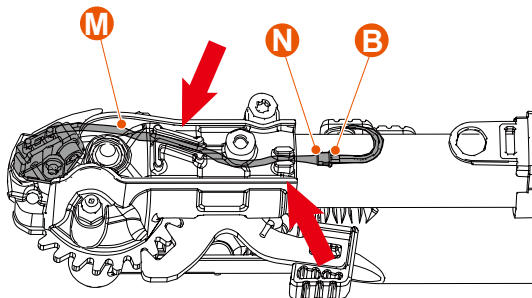

14. Attach the interlock switch cover.
15. Attach the trigger holder.

Related Topics

- [5-1 Switch and Trigger Components \(p.44\)](#)
- [5-10 Remove the Interlock Switch \(p.50\)](#)
- [5-9 Attach the Interlock Switch Cover \(p.49\)](#)
- [5-2 Remove/Attach the Trigger Holder \(p.45\)](#)

6. Disassemble/Assemble the Upper Gear Case

6-1 Upper Gear Case Components

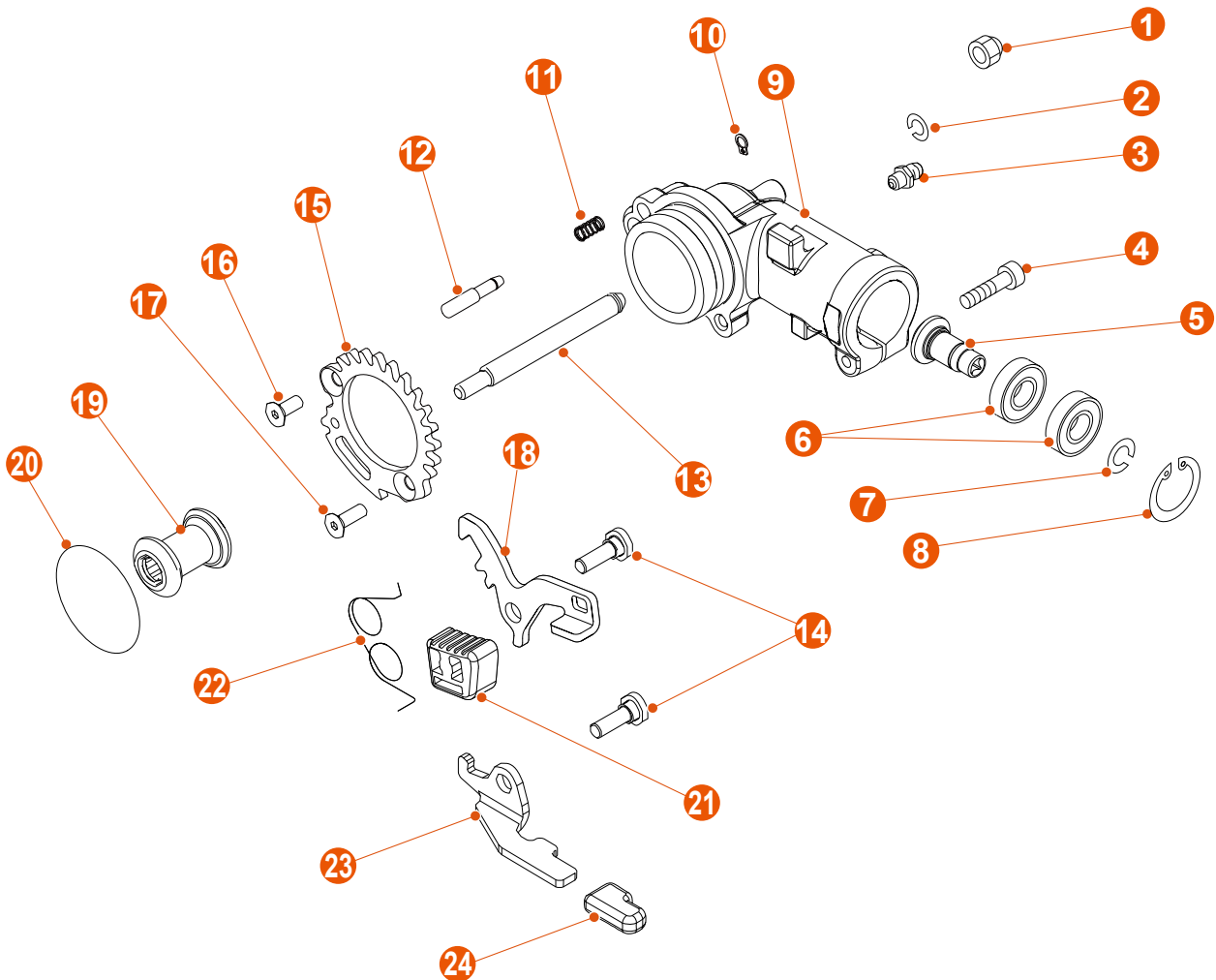

- | | | | |
|----|--------------------|----|----------------|
| 1 | Lock nut | 13 | Gear shaft |
| 2 | Retaining ring | 14 | Hex.bolt (M6) |
| 3 | Grease nipple | 15 | Latch resetter |
| 4 | Torx bolt (M5) | 16 | Hex.bolt (M5) |
| 5 | Bevel gear | 17 | Hex.bolt (M5) |
| 6 | Ball bearing | 18 | Release lever |
| 7 | Retaining ring | 19 | Bevel gear |
| 8 | Retaining ring | 20 | O-ring |
| 9 | Upper gear case | 21 | Cap |
| 10 | Retaining ring | 22 | Coil spring |
| 11 | Compression spring | 23 | Safety lever |
| 12 | Pin | 24 | Cap |

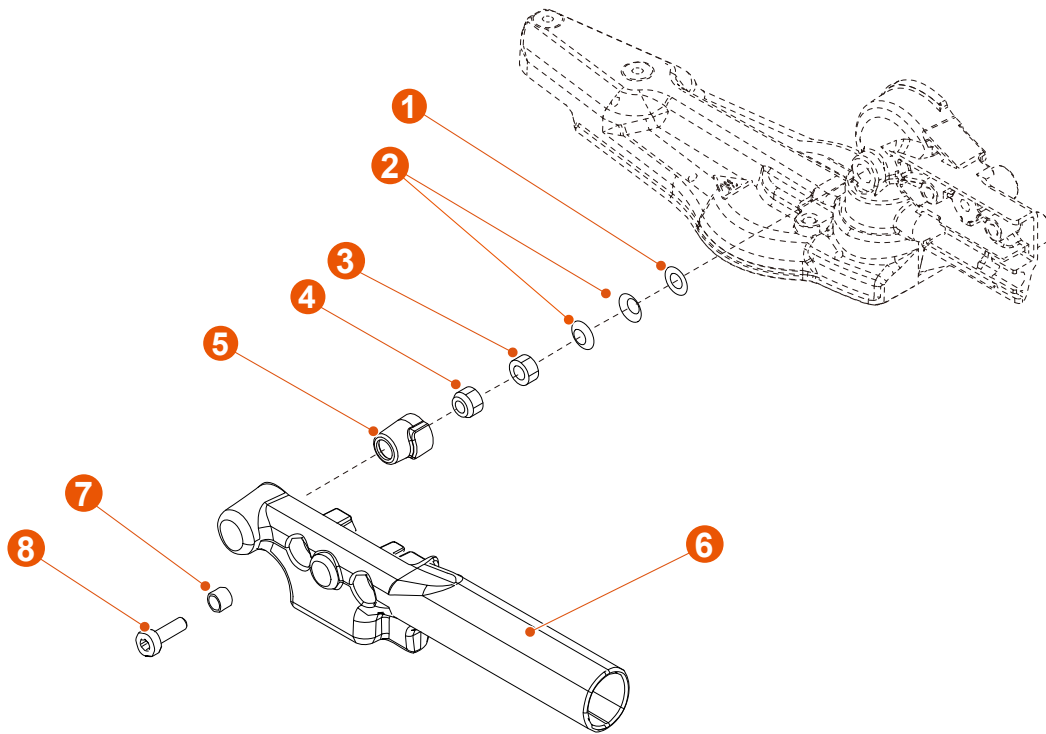

- 1 Washer
- 2 Wave washer
- 3 Nut
- 4 Lock nut

- 5 Dust cover
- 6 Handle grip
- 7 Collar
- 8 Torx bolt (M5)

6-2 Remove the Upper Gear Case

Prerequisites

- Remove the following parts.
 - (1) Inter rock switch
 - (2) Main pipe
- Tools required:
 - Piston pin tool
 - Heat gun
 - T-hex wrench
 - Torx wrench (T27)
 - Piston pin tool

Procedure

1. Remove the 2 Torx bolts **A** and 2 collars **B**.

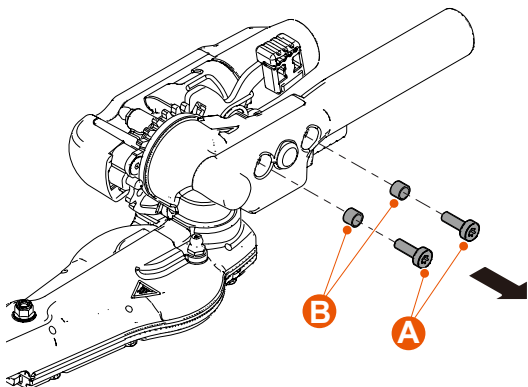

2. Remove the handle grip **C** from the gear case.

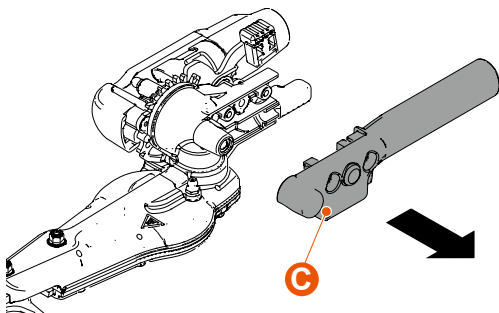

3. Remove the following parts.

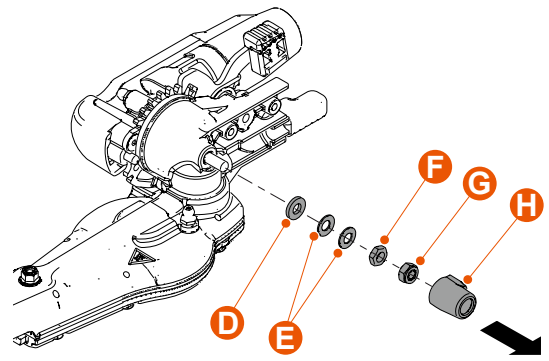

- Washer **D**
- Wave washer **E**
- Nut **F**
- Lock nut **G**
- Dust cover **H**

4. Grip the release lever **J** and safety lever **K** and then pull out the upper gear case as shown.

5. Remove the bevel gear **L** from the upper gear case.

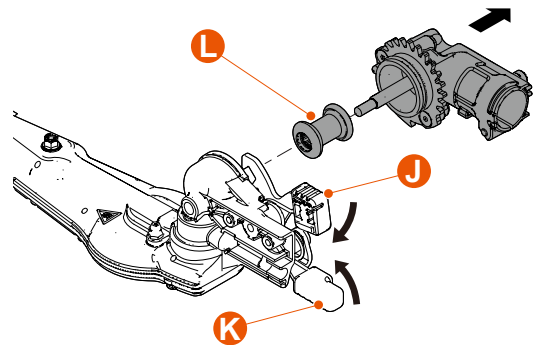

6. Remove the o-ring **Q** from the upper gear case.

7. Remove the following parts.

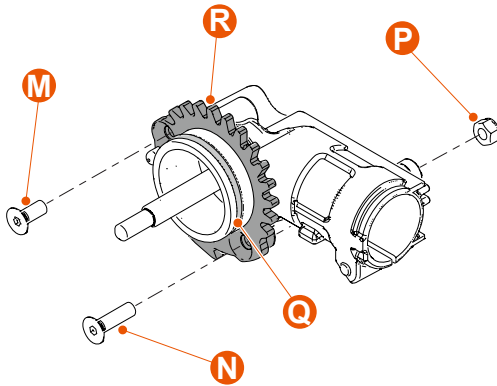

- Hex.bolt **M** (M5×12)
- Hex.bolt **N** (M5×18)
- Lock nut **P**
- Latch resetter **R**

8. Remove the Grease nipple **S**.

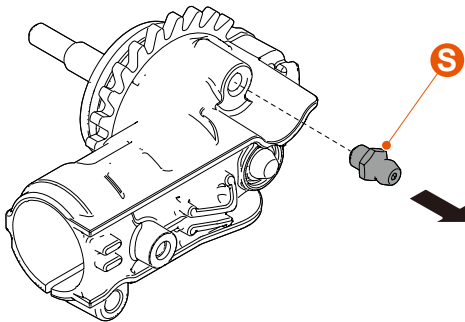

9. Remove the retaining ring **T**.

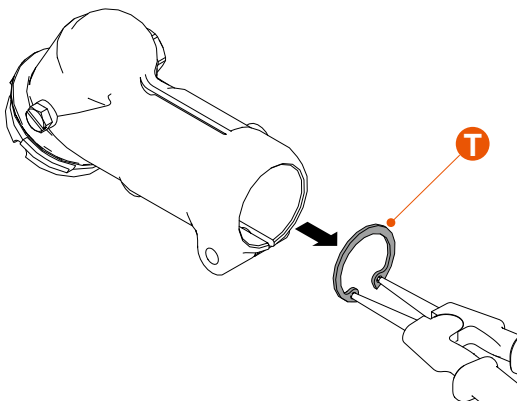

10. Heat up the middle of the upper gear case with a heat gun as shown.

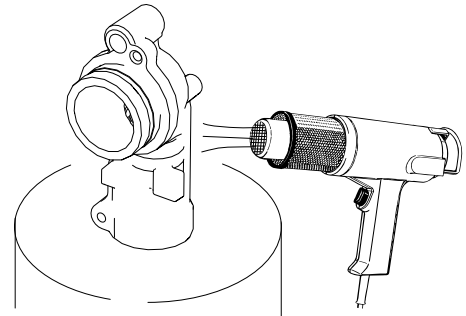

CAUTION

- When using a heat gun, put on the gloves. Otherwise, a burn will result.

11. Tap the gear case vertically against a flat surface several times until bevel gear **U** with the 2 ball bearings **V** come out.

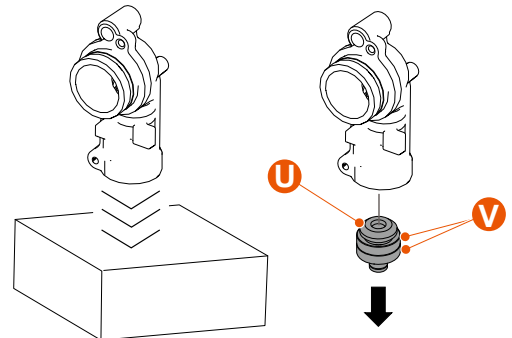

12. Push out the gear shaft **W** as shown.

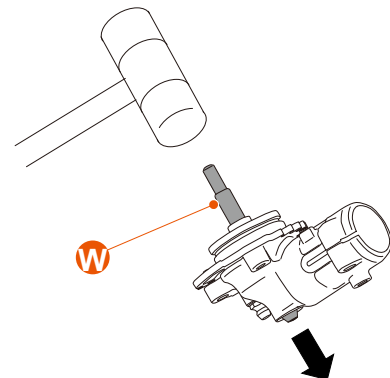

13. Remove the retaining ring **X** from the gear shaft **W**.

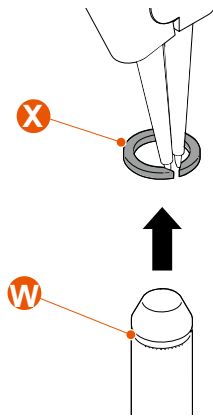

14. Inspect the removed parts.

If any deformation, damage, or wear is found, replace the parts with new ones.

Related Topics

- [6-1 Upper Gear Case Components \(p.54\)](#)
- [6-3 Attach the Upper Gear Case \(p.58\)](#)
- [5-10 Remove the Interlock Switch \(p.50\)](#)
- [9-2 Remove/Attach the Main Pipe and Flexible Shaft \(p.74\)](#)

6-3 Attach the Upper Gear Case

Prerequisites

- Required tools and materials:
 - Piston pin tool
 - Oil seal tool
 - Heat gun
 - T-hex wrench
 - Thread locking sealant (ThreeBond #1344J or equivalent)
 - Lithium-based grease

Procedure

1. Attach a new retaining ring **A** to the groove of the gear shaft.

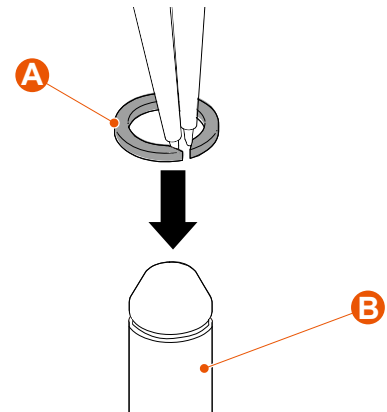

2. Heat up the Upper gear case with a heat gun as shown.

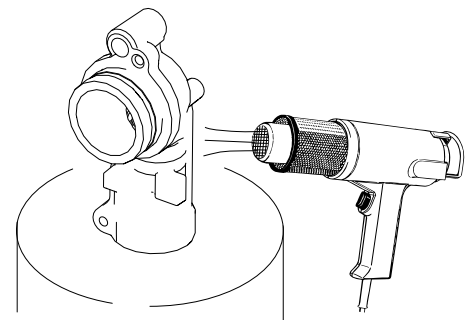

CAUTION

- When using a heat gun, put on the gloves. Otherwise, a burn will result.

3. Insert the gear shaft **B** into the upper gear case using the piston pin tool guide No.6 **C** or a suitable tool.

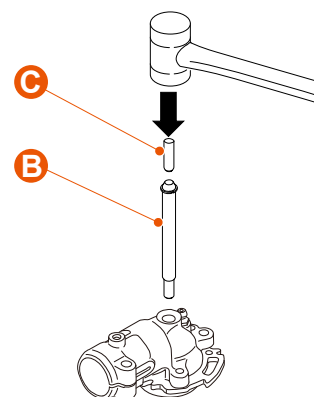

NOTICE

- Insert the gear shaft **B** until the retaining ring **A** touches to the surface of the gear case as shown.

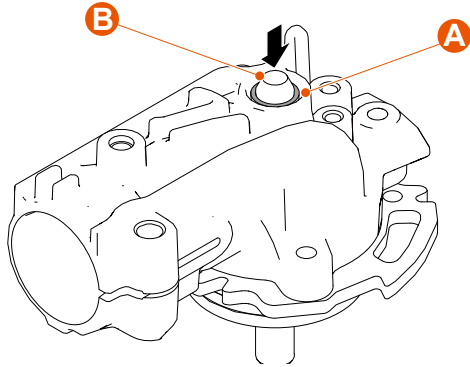

4. Heat up the middle of the upper gear case with a heat gun as shown.

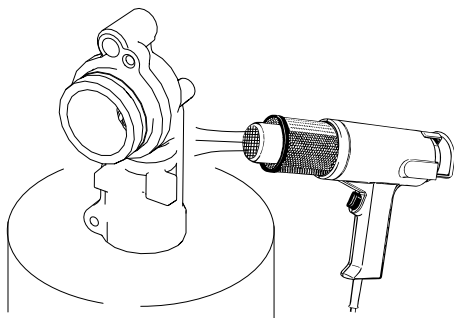

CAUTION

- When using a heat gun, put on the gloves. Otherwise, a burn will result.

5. Insert the bevel gear **E** with the ball bearings **D** into the upper gear case using oil seal tool **F** as shown.

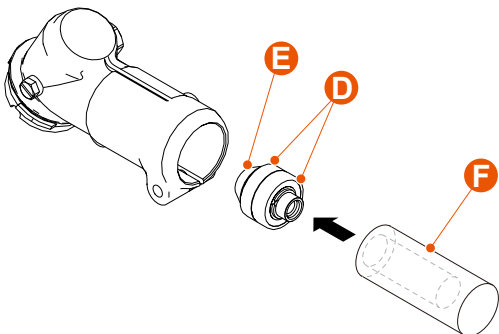

NOTICE

- Make sure that the bevel gear **E**, ball bearings **D** are seated in the correct position of the gear case as shown.

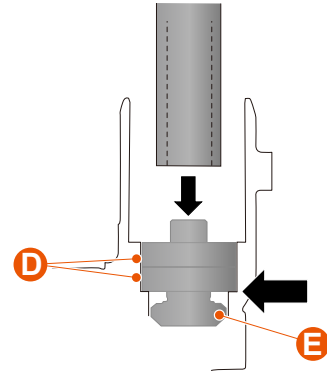

6. Attach a new retaining ring **H**.

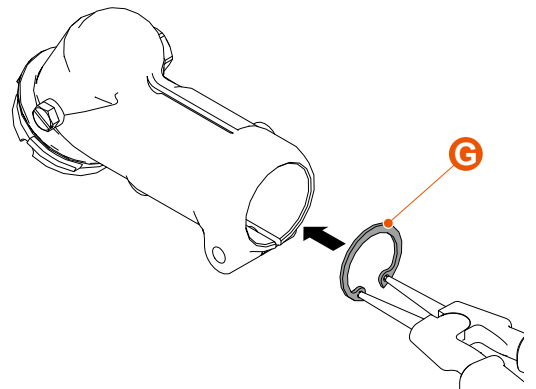

NOTICE

- The chamfered surface of the retaining ring **G** should face the ball bearing.

7. Attach the latch resetter **H**.
8. Attach the O-ring **J**.
9. Apply thread locking sealant (ThreeBond #1344J or equivalent) to the Hex bolt **K** and Hex bolt **L**.

10. Attach the following parts.

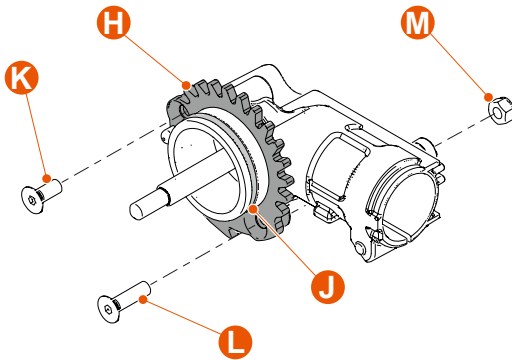

- Hex.bolt **K** (M5×12)
- Hex.bolt **L** (M5×18)
- Lock nut **M**

11. Attach the bevel gear **N** to the upper gear case.

12. Grip the release lever **P** and safety lever **Q** and then insert the upper gear case.

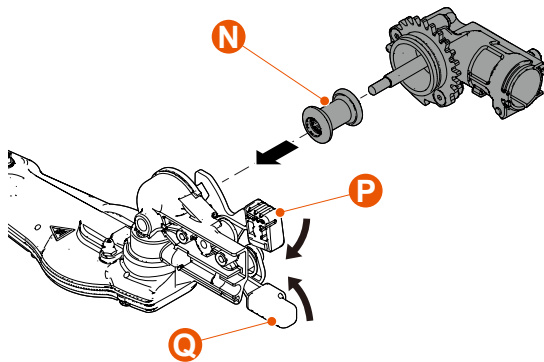

13. Apply lithium based grease to the surface of the outer wave washer **S** only.

14. Attach the following parts.

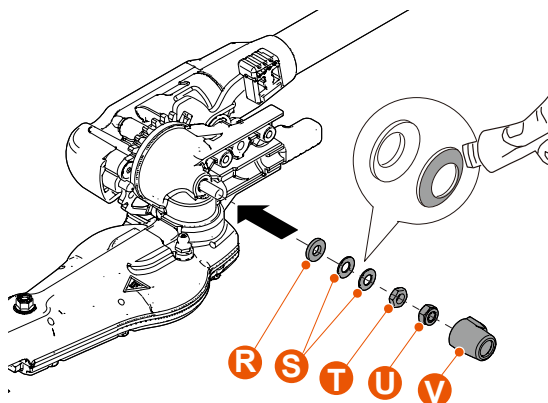

- Washer **R**
- Wave washer **S**
- Nut **T**
- Lock nut **U**
- Dust cover **V**

15. Attach the handle grip **W** to the gear case.

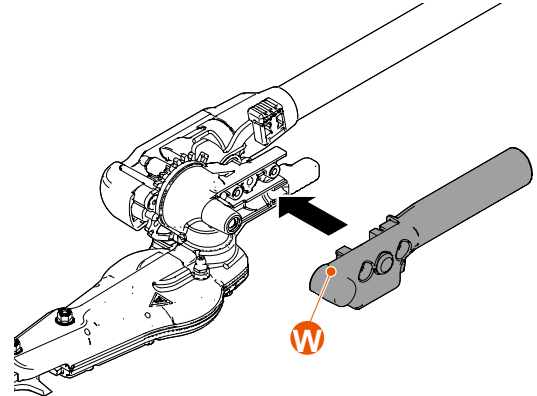

16. Attach the 2 bolts **X** and 2 collars **Y**.

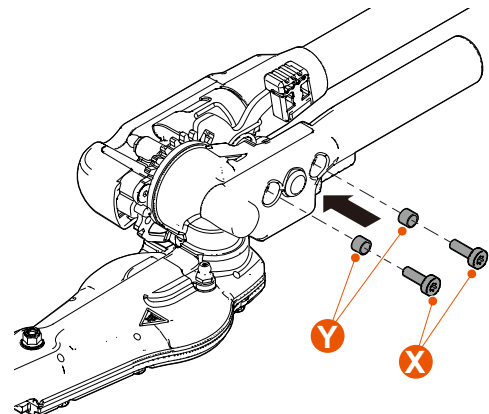

17. Attach the main pipe.

18. Inject 12 g to 18 g of lithium-based grease into the upper gear case through the grease nipple **Z**.

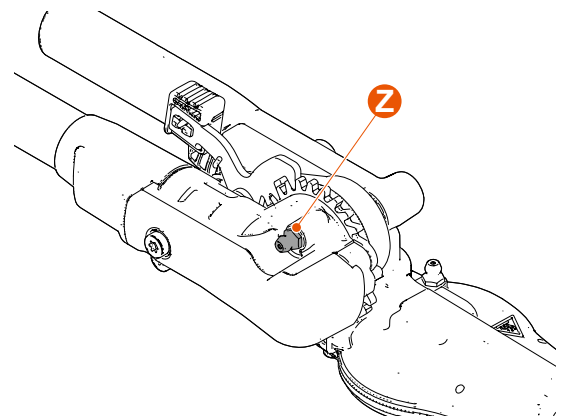

19. Attach the interlock switch.
20. Attach the main pipe.

Related Topics

- [6-1 Upper Gear Case Components \(p.54\)](#)
- [6-2 Remove the Upper Gear Case \(p.56\)](#)
- [5-11 Attach the Interlock Switch \(p.51\)](#)
- [9-2 Remove/Attach the Main Pipe and Flexible Shaft \(p.74\)](#)

6-4 Remove/Attach the Release Lever and Safety Lever

When reinstalling the removed parts, do so in the reverse order from that indicated below.

Prerequisites

- Remove the upper gear case.
- Tools required:
 - Torx wrench (T27)

Procedure

1. Remove the following parts.

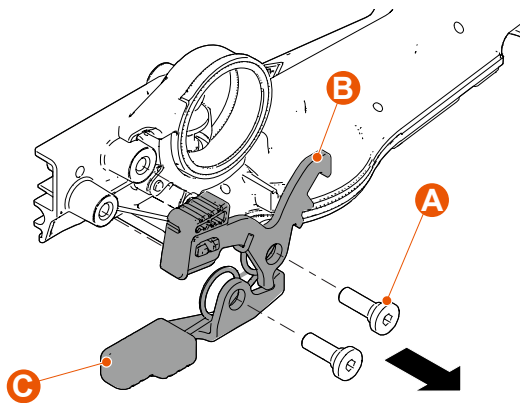

- Hex.bolt **A**
- Release lever **B**
- Safety lever **C**

2. Remove the following parts.

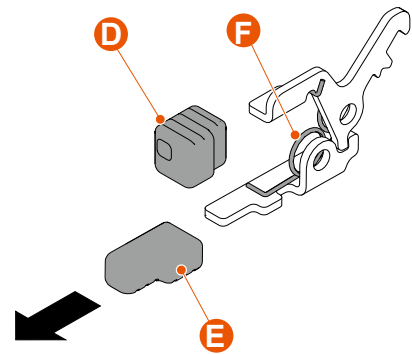

- Cap **D**
- Cap **E**
- Coil spring **F**

3. Inspect the removed parts.

If any deformation, damage, or wear is found, replace the parts with new ones.

Related Topics

- [6-1 Upper Gear Case Components \(p.54\)](#)
- [6-2 Remove the Upper Gear Case \(p.56\)](#)

7. Disassemble/Assemble the Lower Gear Case

7-1 Lower Gear Case Components

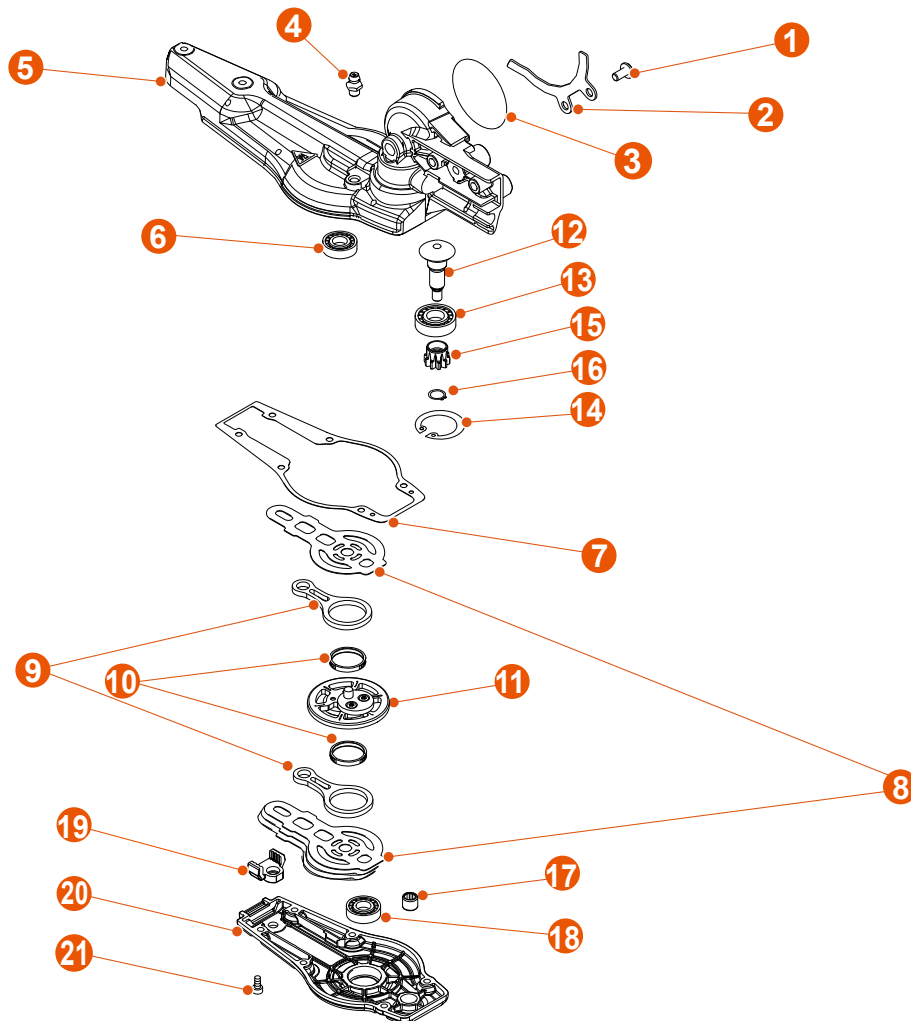

- | | |
|--------------------|-------------------|
| 1 Bolt | 12 Pinion shaft |
| 2 Angle plate | 13 Ball bearing |
| 3 Circular washer | 14 Retaining ring |
| 4 Grease nipple | 15 Spur gear |
| 5 Lower gear case | 16 Retaining ring |
| 6 Ball bearing | 17 Needle bearing |
| 7 Gear case gasket | 18 Ball bearing |
| 8 Side plate | 19 Seal |
| 9 Connecting rod | 20 Gear case lid |
| 10 Needle bearing | 21 Torx bolt (M4) |
| 11 Spur gear | |

7-2 Remove the Lower Gear Case

Prerequisites

- Remove the cutter assembly
- Tools required:
 - Torx wrench (T27)
 - Piston pin tool
 - T-hex wrench
 - Heat gun

Procedure

1. Remove the following parts.

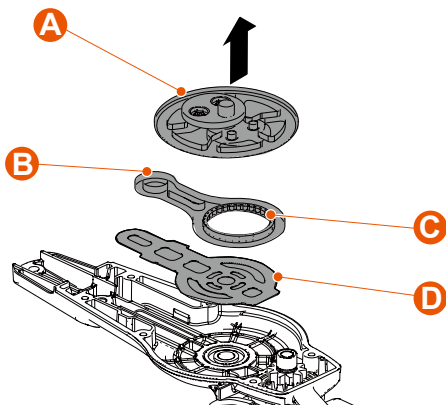

- Spur gear **A**
- Connecting rod **B**
- Needle bearing **C**
- Side plate **D**

2. Remove the grease nipple **E**.

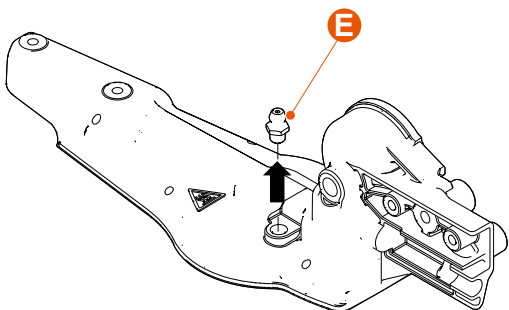

3. Heat up the lower gear case with a heat gun as shown.

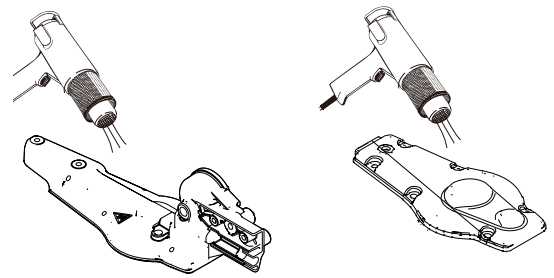

CAUTION

- When using a heat gun, put on the gloves. Otherwise, a burn will result.

4. Tap the gear case vertically against a flat surface several times until the ball bearings **F** and needle bearing **G** come out.

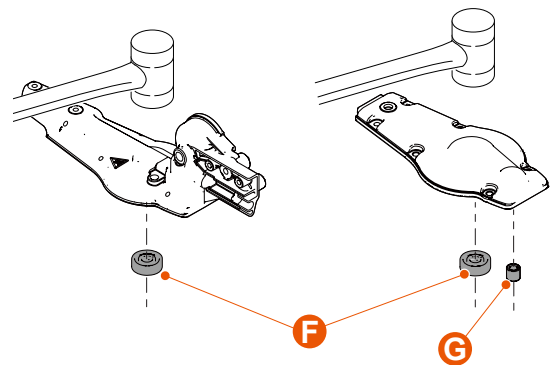

5. Remove the retaining ring **H**.

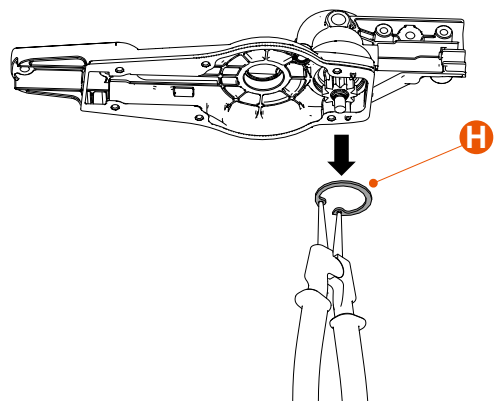

6. Heat up the lower gear case with a heat gun as shown.

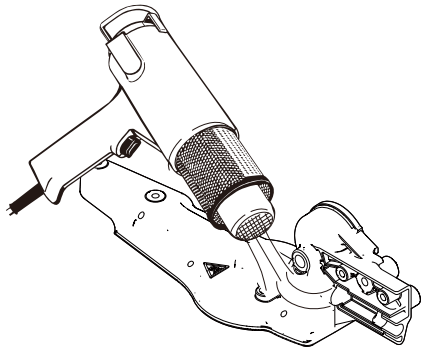

CAUTION

- When using a heat gun, put on the gloves. Otherwise, a burn will result.

7. Tap the gear case several times removing the following parts.

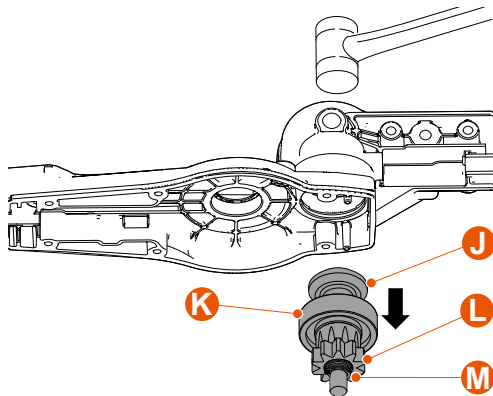

- Pinion shaft **J**
- Ball bearing **K**
- Spur gear **L**
- Retaining ring **M**

8. Inspect the removed parts.

If any deformation, damage, or wear is found, replace the parts with new ones.

Related Topics

- [7-1 Lower Gear Case Components \(p.62\)](#)
- [7-3 Attach the Lower Gear Case \(p.64\)](#)
- [6-2 Remove the Upper Gear Case \(p.56\)](#)

7-3 Attach the Lower Gear Case

Prerequisites

- Required tools and materials:
 - Oil seal tool
 - Lithium-based grease
 - New retaining ring

Procedure

1. Heat up the lower gear case with a heat gun as shown.

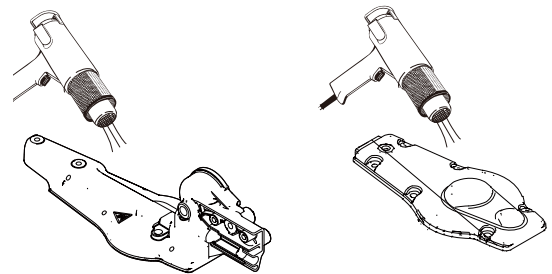

CAUTION

- When using a heat gun, put on the gloves. Otherwise, a burn will result.

2. Insert the ball bearings **A** into the lower gear case and gear case lid using oil seal tools **B** as shown.

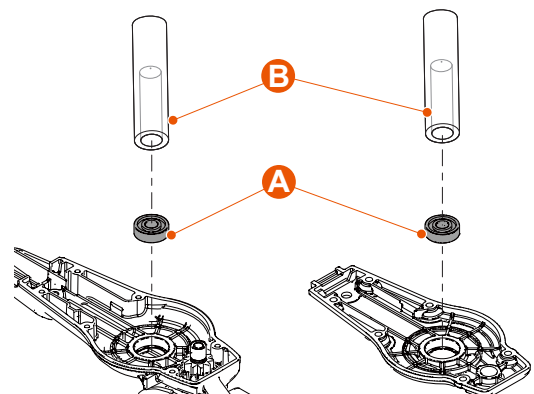

3. Insert the needle bearing **C** into the gear case lid using oil seal tool **B** as shown.

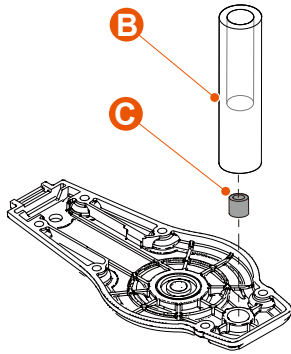

NOTICE
Use the oil seal tool upside down when insert the needle bearing.

4. Attach the following parts using oil seal tool **B**.

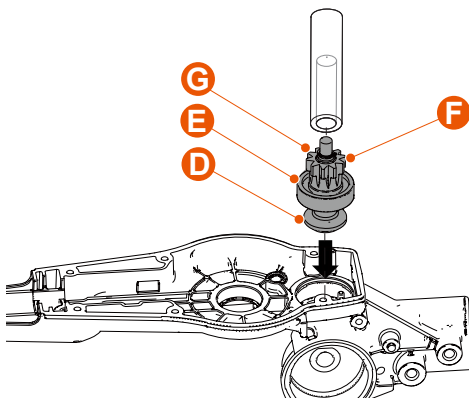

- Pinion shaft **D**
- Ball bearing **E**
- Spur gear **F**
- Retaining ring **G**

5. Attach the 1 side plate **H** to the gear case.

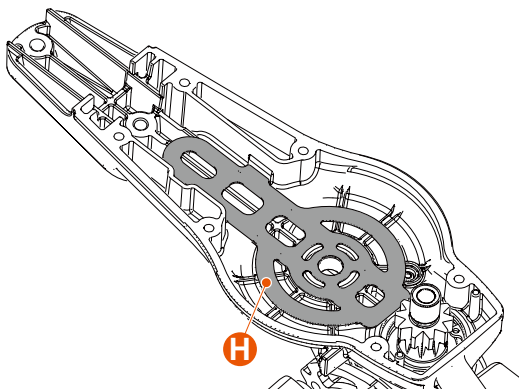

6. Apply lithium base grease **J** to the small end inner surfaces of the connecting rod **K**.

7. Attach the needle bearing **L** to the connecting rod **K**.

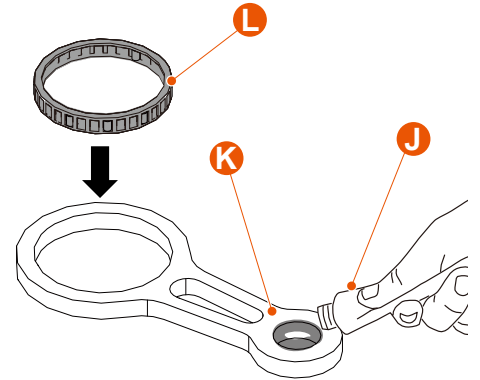

8. Put the connecting rod **K** to the spur gear **M**.

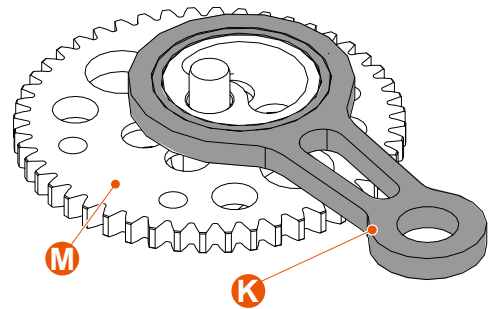

9. Attach the spur gear **M** and the connecting rod **K** in the gear case.

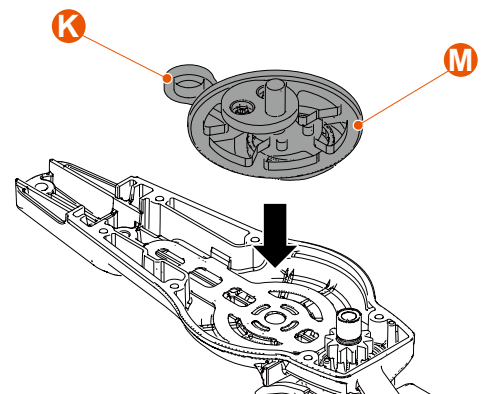

10. Attach the cutter assembly.

Related Topics

- [7-1 Lower Gear Case Components \(p.62\)](#)
- [7-2 Remove the Lower Gear Case \(p.63\)](#)
- [6-3 Attach the Upper Gear Case \(p.58\)](#)

8. Disassemble/Assemble the Cutter

8-1 Cutter Components

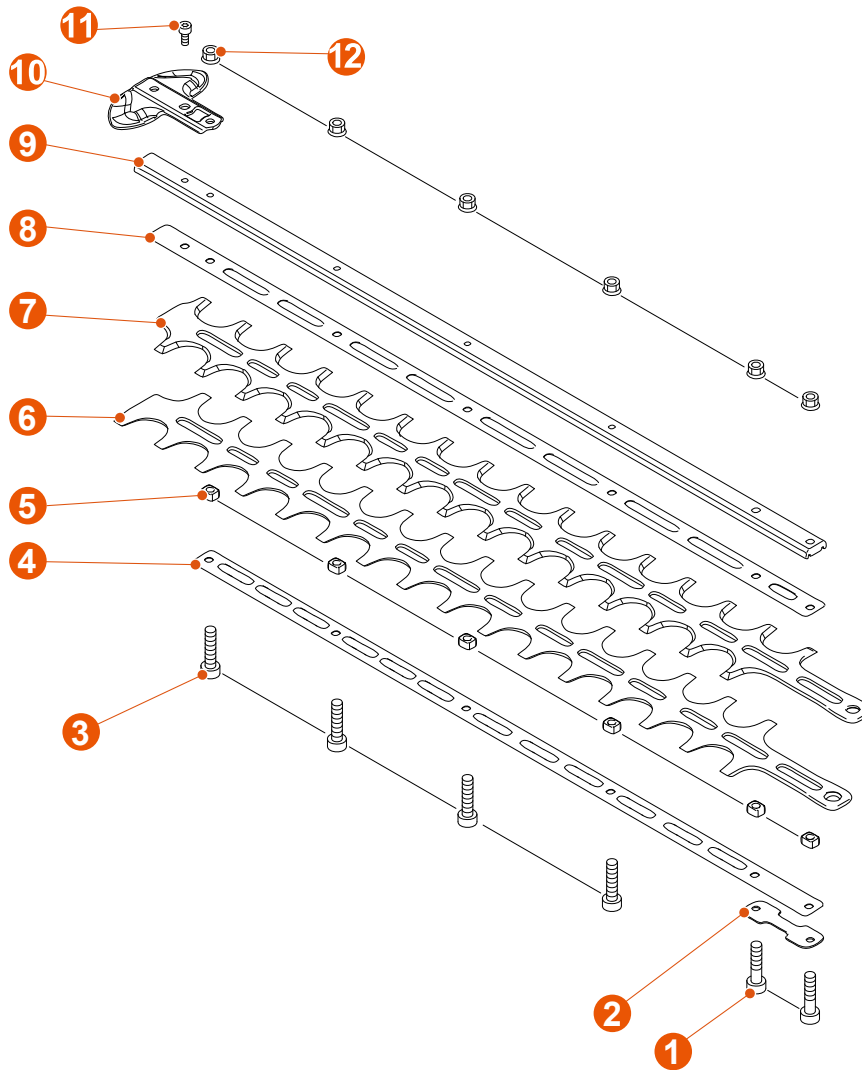

- 1 Torx bolt (M5)
- 2 Eye plate
- 3 Torx bolt (M5)
- 4 Cutter support
- 5 Collar
- 6 Cutter

- 7 Cutter
- 8 Cutter support
- 9 Cutter support
- 10 Protector
- 11 Torx bolt (M5)
- 12 Flange nut

8-2 Remove the Cutter Assembly

Prerequisites

- Prepare safety gloves.

CAUTION

- Wear safety gloves when removing or attaching the cutter assembly to protect your hands from injury.

- Tools required:
 - Torx wrench (T27)

Procedure

1. Remove the 6 Torx bolts **A**.
2. Remove the gear case lid **B**.

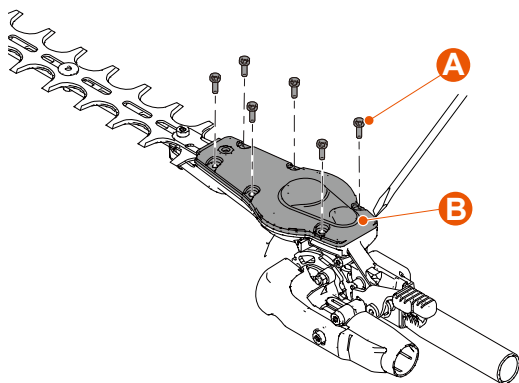

3. Remove the following parts.

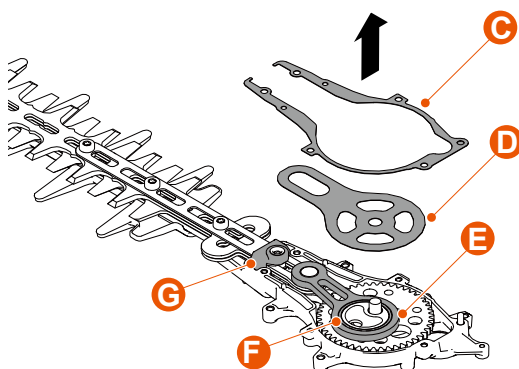

- Gear case gasket **C**
- Side plate **D**
- Connecting rod **E**
- Needle bearing **F**
- Seal **G**

4. Remove the 2 nuts **H**.
5. Remove the following parts.

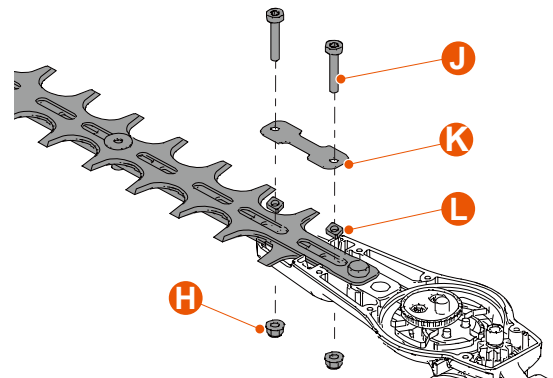

- Bolt **J**
- Eye plate **K**
- Collar **L**
- Cutter Assembly

6. Inspect the removed parts.

If any deformation, damage, or wear is found, replace the parts with new ones.

Related Topics

- [8-1 Cutter Components \(p.67\)](#)

8-3 Attach the Cutter Assembly

Prerequisites

- Prepare safety gloves.

CAUTION

- Wear safety gloves when removing or attaching the cutter assembly to protect your hands from injury.

- Required tools and materials:

- Lithium-based grease
- Torx wrench (T27)
- Spanner wrench
- Thread locking sealant (ThreeBond #1324N or equivalent)
- New gear case gasket

Procedure

1. Attach the cutter assembly in the gear case so that the pin **A** matches to the hole of the connecting rod **B**.

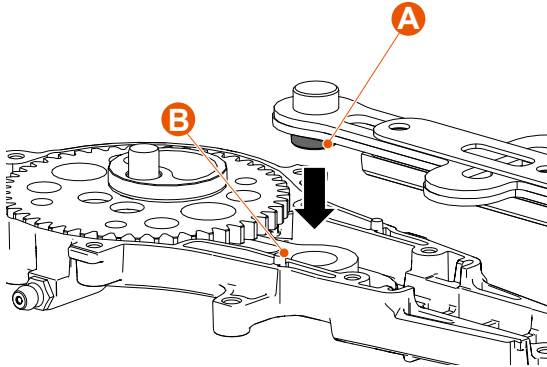

2. Place the 2 collars **C** and the 2 eye plates **D** on the cutter.
3. Tighten the 2 bolts **E** with 5.0 - 7.0 N · m.

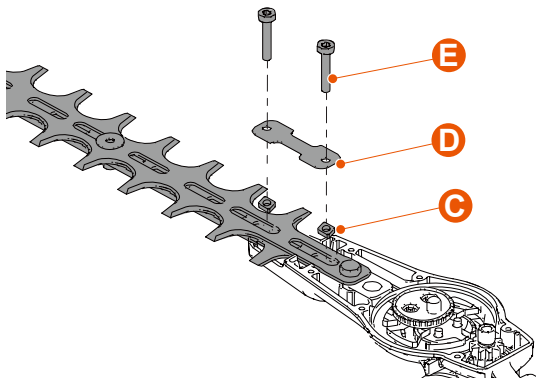

4. Tighten the 2 nuts **F** with 5.0 - 7.0 N · m, holding the 2 bolts with a Torx wrench.

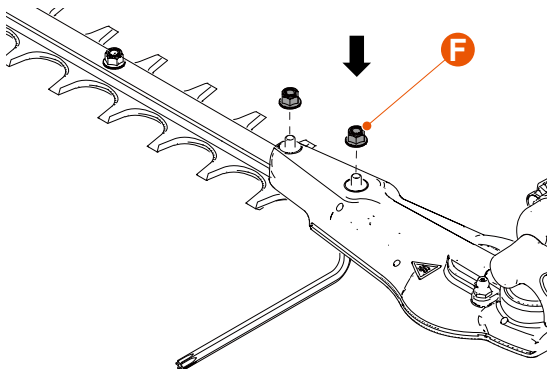

5. Apply lithium base grease **G** to the small end inner surfaces of the connecting rod **H**.

6. Attach the needle bearing **J** to the connecting rod **H**.

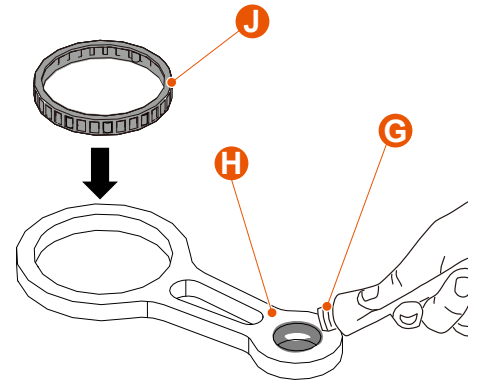

7. Attach the connecting rod **H** to the spur gear **K**.

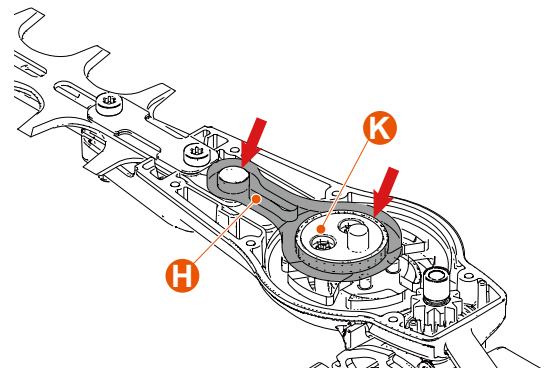

NOTICE

- Make sure that the both ends of the connecting rod **H** are placed in the correct position.

8. Attach the following parts.

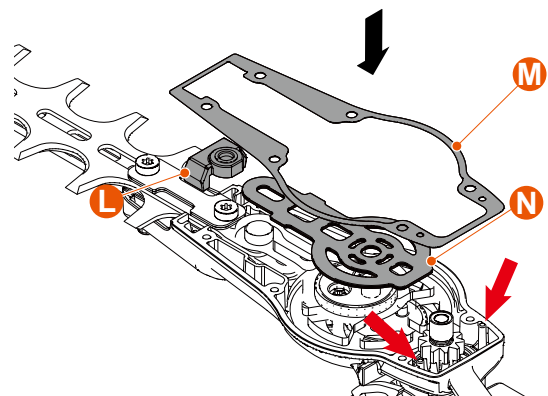

- Seal **L**
- Gear case gasket **M**
- 3 Side plate **N**

NOTICE

- Make sure that the boss of the lower gear case is inserted to the holes of the gear case gasket.

9. Attach the gear case lid **P**.
10. Apply thread locking sealant (ThreeBond #1324N or equivalent) to the holes of the gear case lid **P**.
11. Tighten the 6 Torx bolts **Q**.

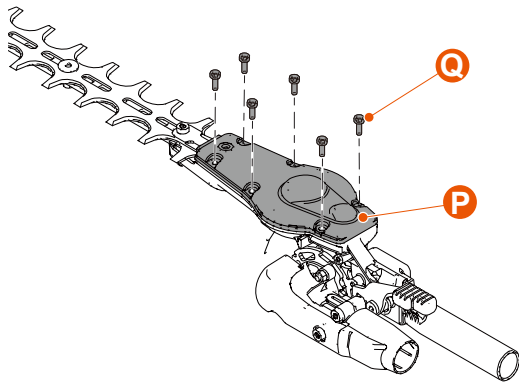

NOTICE

- Wipe off the thread locking sealant (ThreeBond #1324N or equivalent) that has been spilled.

12. Inject 37 g to 43 g of lithium based grease into the gear case through the grease nipple **R**.

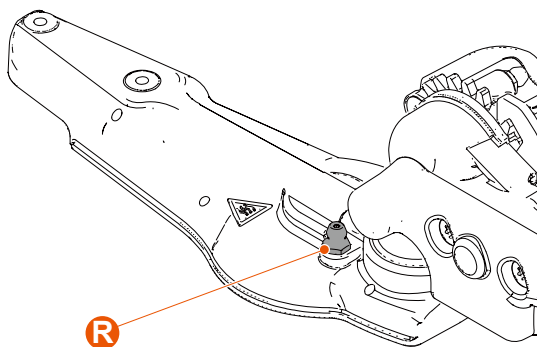

Related Topics

- [8-1 Cutter Components \(p.67\)](#)

8-4 Remove the Cutter

Prerequisites

- Remove the cutter assembly.
- Prepare safety gloves.

⚠ CAUTION

- Wear safety gloves when disassembling or assembling the cutter to protect your hands from injury.

- Tools required:

- Torx wrench (T27)
- Spanner wrench

Procedure

1. Remove the 4 flange nuts **A**.

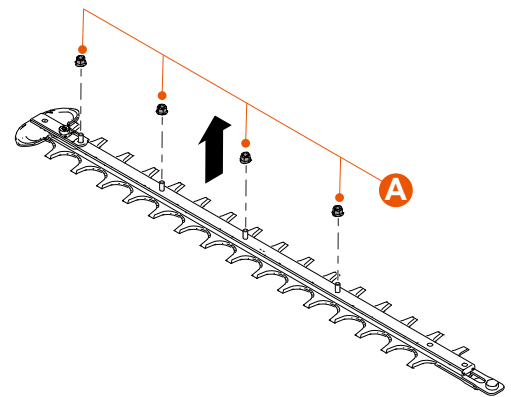

2. Remove the bolt **B**.
3. Remove the protector **C**.

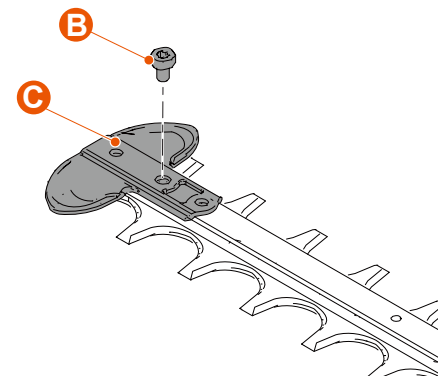

4. Remove the 4 bolts **D**.

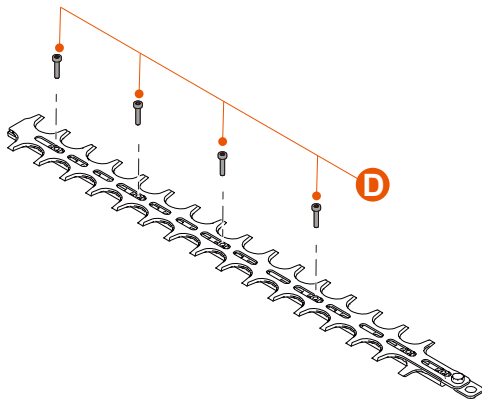

5. Remove the following parts.

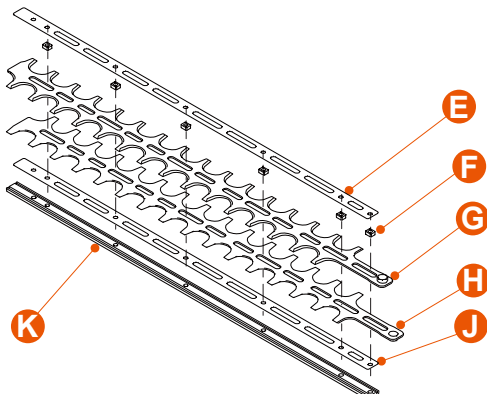

- Cutter support **E**
- Collar **F**
- Cutter **G**
- Cutter **H**
- Cutter support **J**
- Cutter support **K**

6. Inspect the removed parts.

If any deformation, damage, or wear is found, replace the parts with new ones.

Related Topics

- [8-1 Cutter Components \(p.67\)](#)
- [8-5 Attach the Cutter \(p.71\)](#)
- [8-2 Remove the Cutter Assembly \(p.68\)](#)

8-5 Attach the Cutter

Prerequisites

- Prepare safety gloves.

CAUTION

- Wear safety gloves when disassembling or assembling the cutter to protect your hands from injury.

- Tools required:

- Torx wrench (T27)
- Spanner wrench

Procedure

1. Temporarily assemble the following parts.

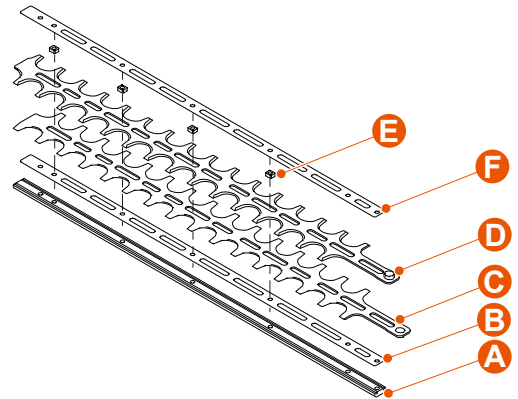

- Cutter support **A**
- Cutter support **B**
- Cutter **C**
- Cutter **D**
- Collar **E**
- Cutter support **F**

NOTICE

Make sure the shorter cutter support **F** is on top.

2. Tighten the 4 bolts **G**.

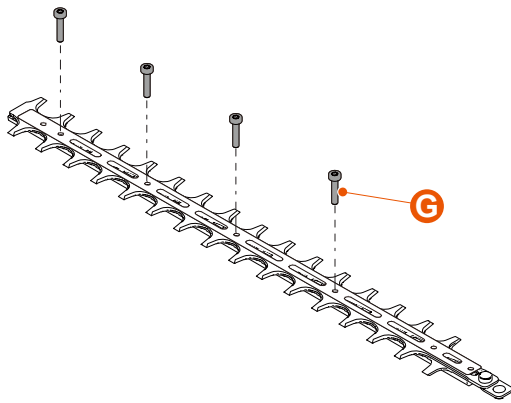

3. Attach the protector **H**.

4. Tighten the bolt **J**.

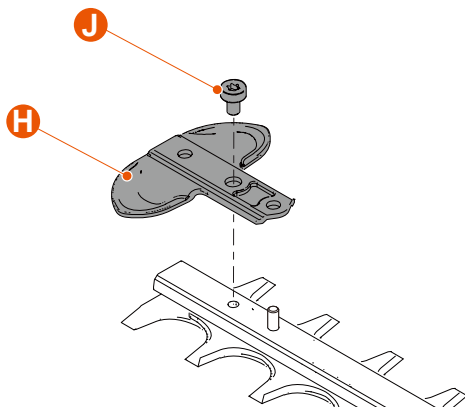

5. Tighten the 4 nuts **K** with 5.0 - 7 N · m, holding the 4 Torx bolt **L** with the Torx wrench **M**.

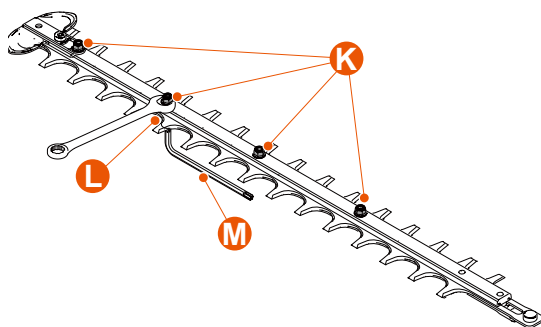

6. Attach the cutter assembly.

Related Topics

- [8-1 Cutter Components \(p.67\)](#)
- [8-4 Remove the Cutter \(p.70\)](#)
- [8-3 Attach the Cutter Assembly \(p.68\)](#)

9. Disassemble/Assemble the Main Pipe and Flexible Shaft

9-1 Main Pipe and Flexible Shaft Components

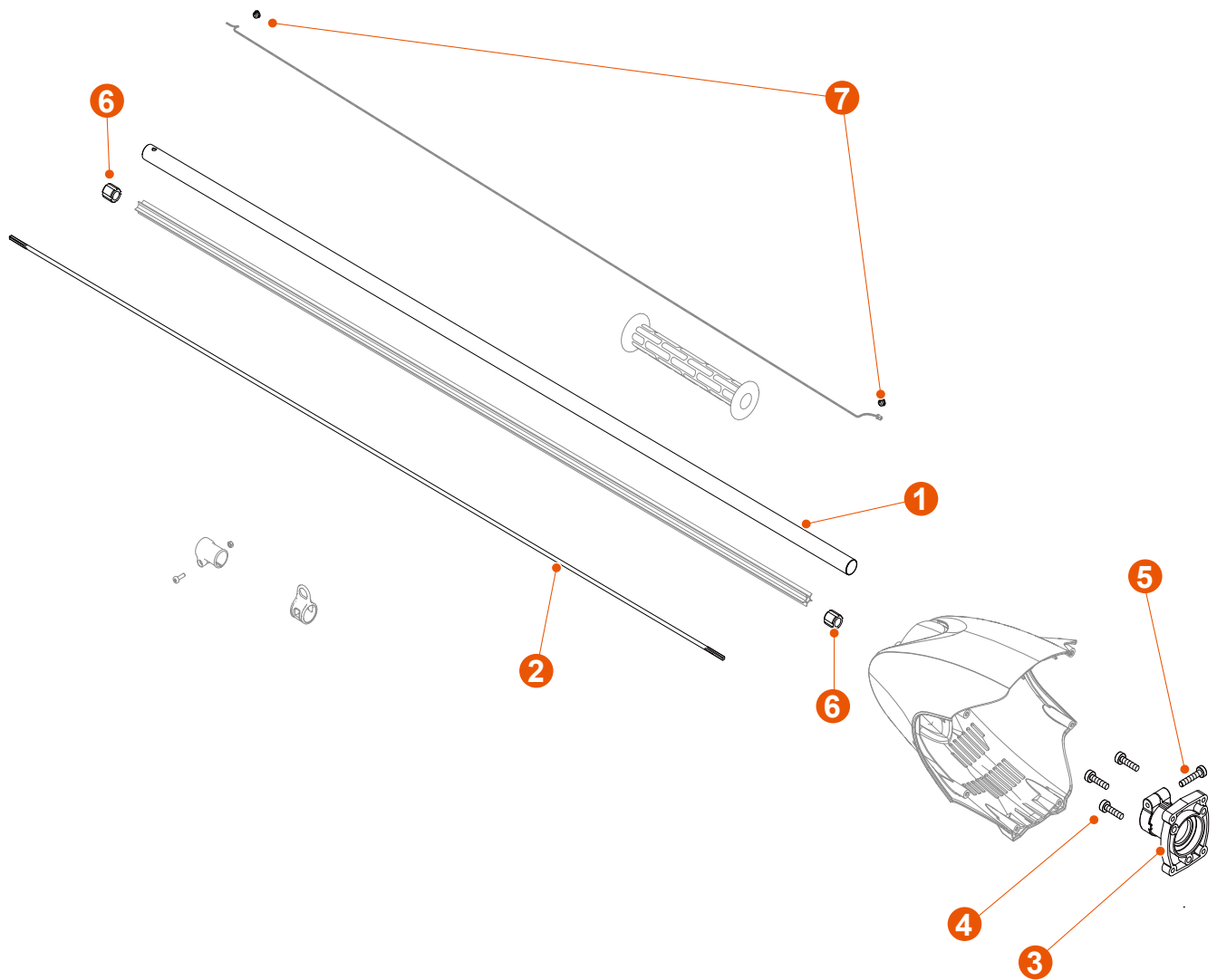

- 1** Main pipe
- 2** Flexible shaft
- 3** Main pipe fixture
- 4** Torx bolt(M5)
- 5** Torx bolt(M5)
- 6** Stopper
- 7** Grommet

9-2 Remove/Attach the Main Pipe and Flexible Shaft

When reinstalling the removed parts, do so in the reverse order from that indicated below.

Prerequisites

- Remove the following parts.
 - (1) Trigger holder
 - (2) Interlock switch cover
- Tools required:
 - Torx wrench (T27)

Procedure

1. Disconnect the connector **A** of the interlock switch.

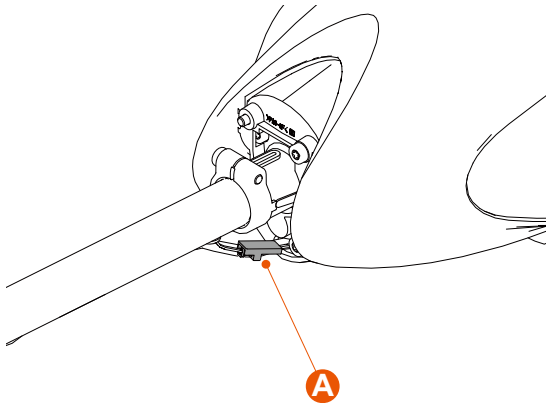

2. Disconnect the connector **B** of the interlock switch.

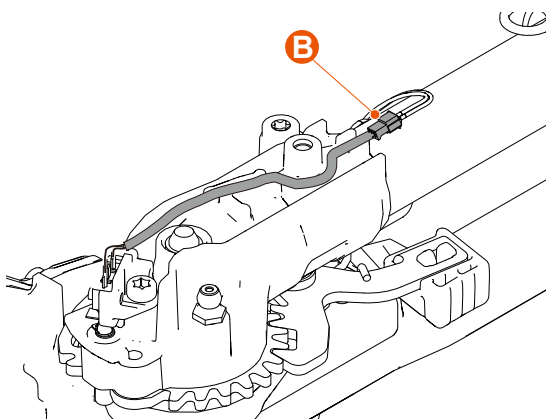

3. Loosen the Torx bolt **C**.

4. Pull out the main pipe.

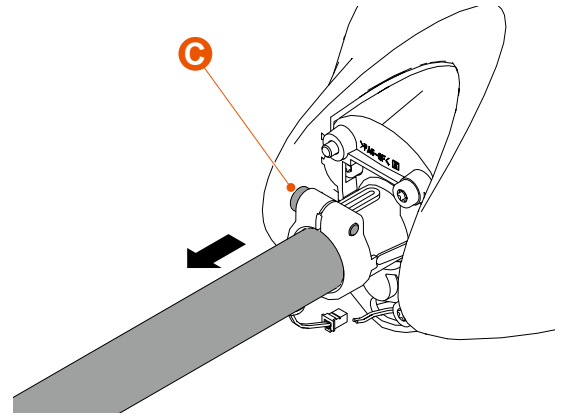

5. Loosen the Torx bolt **D**.

6. Pull out the main pipe from the upper gear case.

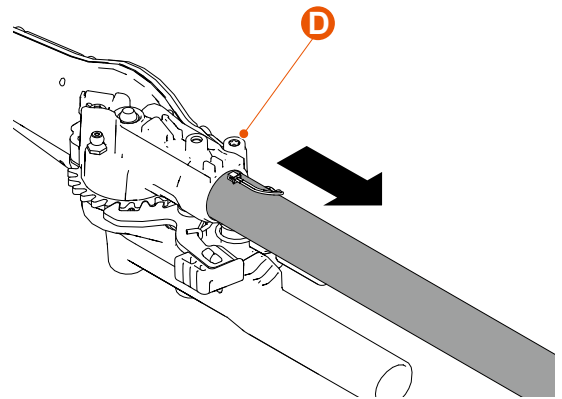

7. Pull out the flexible shaft from the main pipe.

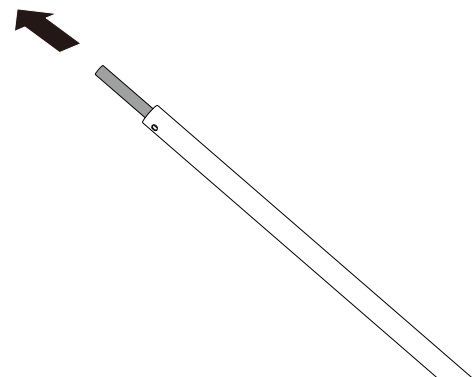

8. Inspect the removed parts.

If any deformation, damage, or wear is found, replace the parts with new ones.

Related Topics

- [9-1 Main Pipe and Flexible Shaft Components \(p.73\)](#)
- [5-2 Remove/Attach the Trigger Holder \(p.45\)](#)
- [5-10 Remove the Interlock Switch \(p.50\)](#)

9-3 Remove/Attach the Main Pipe Fixture

When reinstalling the removed parts, do so in the reverse order from that indicated below.

Prerequisites

- Remove the following parts.
 - (1) Motor cover
- Tools required:
 - Torx wrench (T27)

Procedure

1. Remove the 3 Torx bolts **A**.
2. Remove the main pipe fixture.

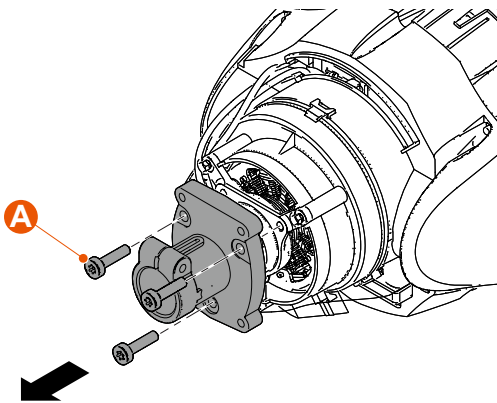

3. Inspect the removed parts.

If any deformation, damage, or wear is found, replace the parts with new ones.

Related Topics

- [9-1 Main Pipe and Flexible Shaft Components \(p.73\)](#)
- [5-2 Remove/Attach the Trigger Holder \(p.45\)](#)
- [5-11 Attach the Interlock Switch \(p.51\)](#)

10. Inspect the Various Parts

10-1 Inspect the Motor Assembly

Prerequisites

- Disconnect the 5-pole terminal connector of the motor assembly from the control board.
- Tools required:
 - Multimeter

Procedure

1. Confirm that there is no short-circuit between terminals [1] and [2] of the motor assembly 5-pole terminal connector.

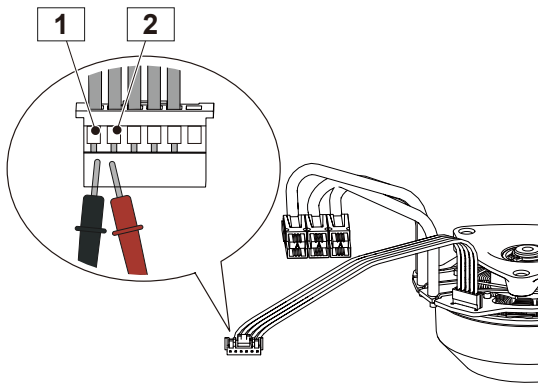

Measure the resistance between terminals [1] and [2] with a multimeter.

- If the multimeter registers infinite resistance : There is no continuity.
- If the multimeter registers zero resistance : There is continuity.

If those 2 points are short-circuited (there is continuity), replace the motor assembly with a new one.

2. Inspect the parts of the motor assembly.

If the following are found, replace the motor assembly with a new one.

- Damage to motor terminals
- Burning or disconnection of motor winding
- Non-smooth rotation or damage in the motor ball bearings

Related Topics

- [4-5 Remove the Motor Assembly \(p.40\)](#)
- [4-6 Attach the Motor Assembly \(p.41\)](#)
- [4-1 Motor and Control Board Assembly Components \(p.37\)](#)

10-2 Inspect the Control board assembly

Prerequisites

- Remove the control board assembly.
- Tools required:
 - Multimeter

Procedure

1. Check that there is no short-circuit between the positive terminal screw **A** and the negative terminal screw **B** of the battery terminal.

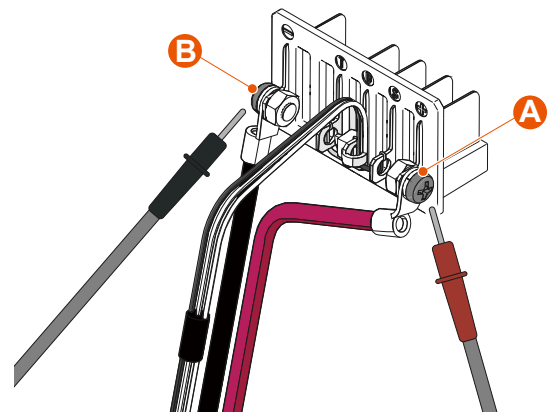

Figure : Battery terminal

Measure the resistance between the positive terminal screw **A** and the negative terminal screw **B** with a multimeter.

- If the multimeter registers infinite resistance : There is no continuity.
- If the multimeter registers zero resistance : There is continuity.

If those 2 points are short-circuited (there is continuity), replace the control board assembly with a new one.

2. Check if any conductive substances, such as water and metal pieces, adhered to the control board assembly.

If conductive substances are adhered to the control board assembly, remove them.

3. Inspect the control board assembly and control board terminals for burning or damage.

If found, replace the control board assembly with a new one.

Related Topics

- [4-7 Remove the Control Board Assembly \(p.42\)](#)
- [4-8 Attach the Control Board Assembly \(p.42\)](#)
- [4-1 Motor and Control Board Assembly Components \(p.37\)](#)

10-3 Inspect the Power Switch

Prerequisites

- Remove the power switch.
- Tools required:
 - Multimeter
- LED tester

Used for inspecting the power indicator (step 3.). If an LED tester is not available, inspect the power switch using coin batteries.

Procedure

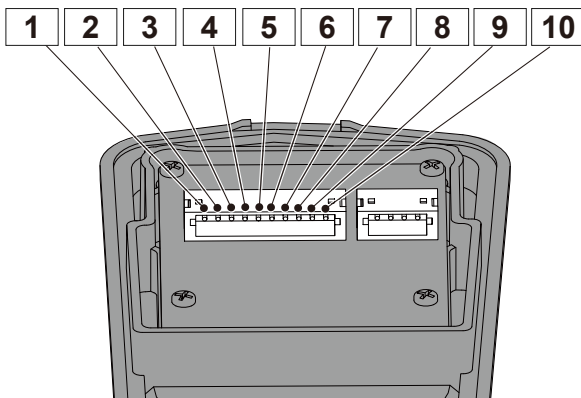

Figure : Power switch (rear)

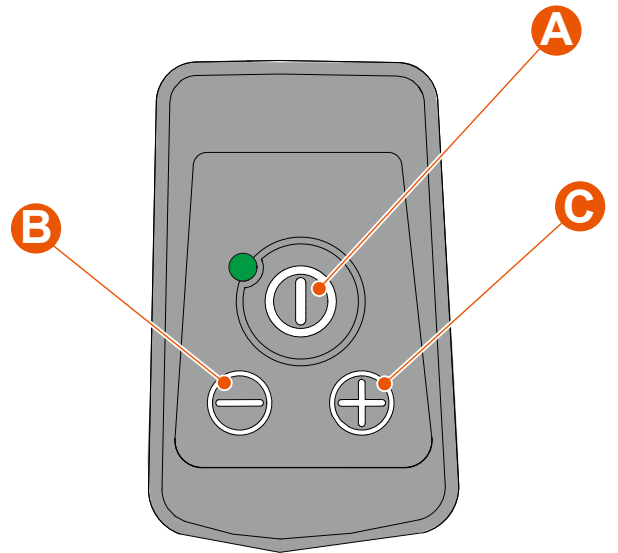

Figure : Power switch (front)

1. Check that there is no short-circuit between terminals [1] and [2] of the power switch.

Measure the resistance between terminals [1] and [2] of the power switch with a multimeter.

- If the multimeter registers infinite resistance : There is no continuity.
- If the multimeter registers zero resistance : There is continuity.

If those 2 points are short-circuited (there is continuity), replace the power switch with a new one.

2. Check that there is no bad connection between the following terminals of the power switch.

Measure the resistance between terminals [2] and [5] of the power switch with a multimeter.

- If the multimeter registers zero resistance when the power switch button **A** is pressed : There is continuity.
- If the multimeter registers infinite resistance when the power switch button **A** is released : There is no continuity.

If the power switch is not in the state above, replace it with a new one.

Measure the resistance between terminals [2] and [9] of the power switch with a multimeter.

- If the multimeter registers zero resistance when the - button **B** is pressed : There is continuity.
- If the multimeter registers infinite resistance when the - button **B** is released : There is no continuity.

If the power switch is not in the state above, replace it with a new one.

Measure the resistance between terminals [2] and [8] of the power switch with a multimeter.

- If the multimeter registers zero resistance when the + button **C** is pressed : There is continuity.
- If the multimeter registers infinite resistance when the + button **C** is released : There is no continuity.

If the power switch is not in the state above, replace it with a new one.

3. Check if the power indicator is intact.

The power indicator can be checked using an LED tester or coin batteries.

If the power indicator does not light up, replace the power switch with a new one.

When using an LED tester

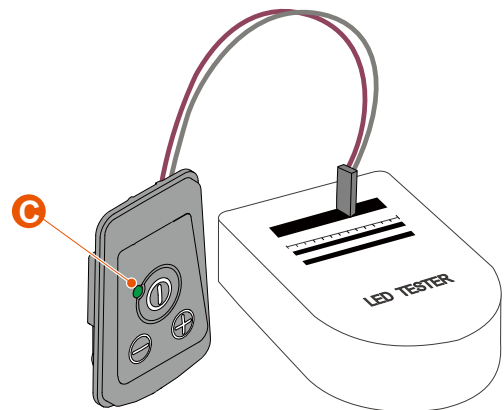

⚠ CAUTION

- When inspecting the power indicator using an LED tester, be sure not to apply electric current higher than 150 mA to the power indicator. It may damage the power indicator.

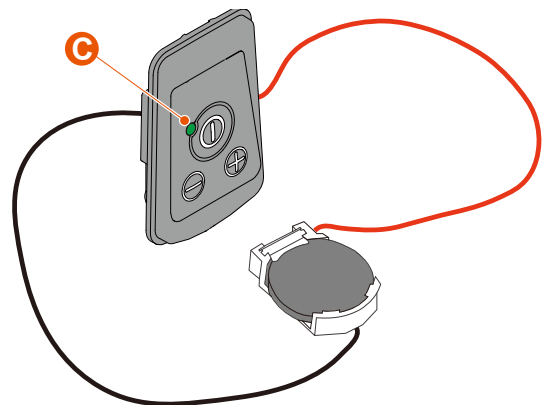

- (1) Connect the positive (+) wire of an LED tester to terminal [1] of the power switch. Likewise, connect the negative (-) wire to terminal [6].
- (2) Apply an electric current of 10 mA to 50 mA and check if the power indicator **C** lights up.

When using coin batteries



⚠ CAUTION

- When inspecting the power indicator using a coin battery, be sure to use one of the following coin battery types.
CR2032 / ECR2032 / DL2032 / SB-T51
If a battery type other than above is used, the power indicator will be damaged due to overcurrent (150 mA or higher).

- (1) Connect the positive (+) wire from the coin battery to terminal [1] of the power switch. Likewise, connect the negative (-) wire to terminal [6].
- (2) Check if the power indicator  lights up.
- (3) If the power indicator  does not light up, connect 2 coin batteries in series and check the power indicator again.

⚠ CAUTION

- When connecting 2 coin batteries in series to check the power indicator, take care to ensure that the connection of the coin batteries and power switch has the correct polarity.
If a voltage of 5 V or higher is applied to the power indicator in the opposite direction, the power indicator will be damaged.

Related Topics

- [5-5 Remove the Power Switch \(p.47\)](#)
- [5-6 Attach the Power Switch \(p.47\)](#)
- [5-1 Switch and Trigger Components \(p.44\)](#)

10-4 Inspect the Variable Speed Switch

Prerequisites

- Remove the variable speed switch.
- Tools required:
 - Multimeter

Procedure

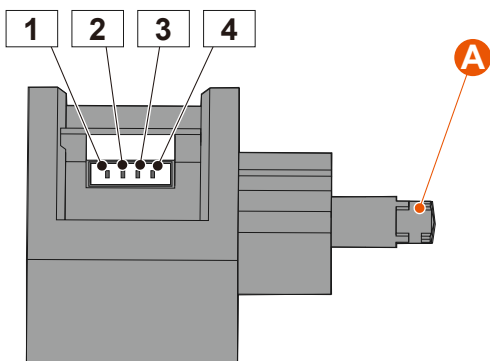

1. **Check that there is no short-circuit between terminals [1] and [3] of the variable speed switch.**



Measure the resistance between terminals [1] and [3] of the variable speed switch with a multimeter.

- If the resistance is 70 kΩ to 130 kΩ : Normal
- If the resistance is outside the range of 70 kΩ to 130 kΩ : Short-circuited

If short-circuited, replace the variable speed switch with a new one.

2. **Check that there is no bad connection between terminals [1] and [4] of the variable speed switch.**



Measure the resistance between terminals [1] and [4] of the variable speed switch with a multimeter.

- If the multimeter registers zero resistance when the switch button  is pressed : There is continuity.
- If the multimeter registers infinite resistance when the switch button  is released : There is no continuity.

If the variable speed switch is not in the state above, replace it with a new one.

3. **Check that there is no abnormal change in resistance when measuring the resistance between terminals [1] and [2] of the variable speed switch.**

Measure the resistance between terminals [1] and [2] of the variable speed switch with a multimeter.

- When the switch button  is pressed : The resistance should be 100 Ω or lower.
- When the switch button  is released : The resistance should be 70 kΩ to 130 kΩ.

If there is abnormal change in resistance, replace the variable speed switch with a new one.

Related Topics

- [5-7 Remove/Attach the Variable Speed Switch \(p.48\)](#)
- [5-1 Switch and Trigger Components \(p.44\)](#)
- [5-10 Remove the Interlock Switch \(p.50\)](#)
- [5-11 Attach the Interlock Switch \(p.51\)](#)

10-5 Inspect the Interlock Switch

This procedure describes how to inspect the interlock switch when interlock switch failure is suspected, such as when the fast blinking of the power switch does not disappear when the cutter is in the cutting position.

Prerequisites

- Remove the battery from the unit.
- Check that the connectors of the interlock switch are securely connected.
- Tools required:
 - Multimeter

Procedure

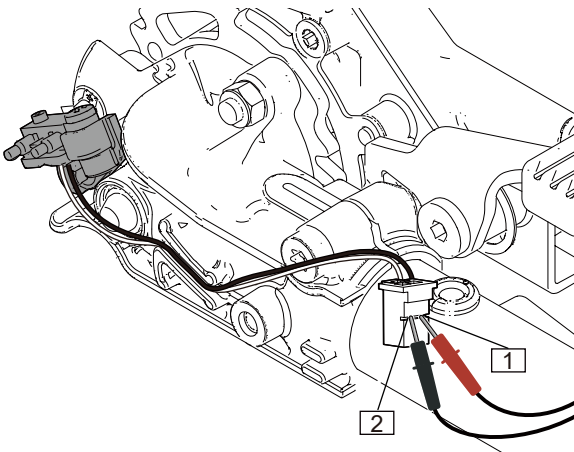

Figure : Figure : Interlock switch

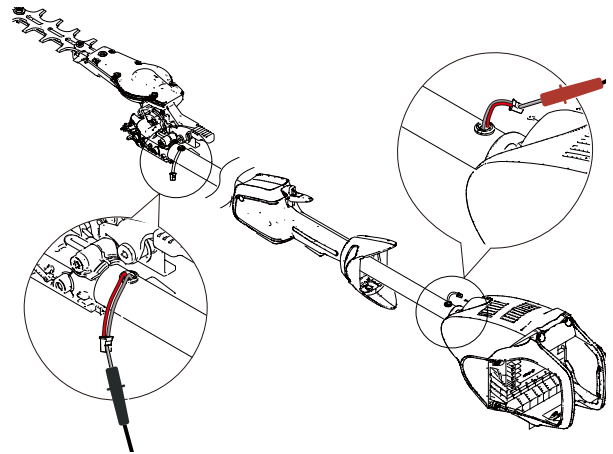

Figure : Figure : Wire harness

1. **Check that there is no bad connection between terminals [1] and [2] of the interlock switch.**

Measure the resistance between terminals [1] and [2] of the interlock switch with a multimeter.

- If the multimeter registers infinite resistance when the cutter blade is closed position : There is no continuity.
- If the multimeter registers zero resistance when the cutter blade is opened 180° from the closed position : There is continuity.

If the interlock switch is not in the state above, replace it with a new one.

2. **Check that there is no bad connection of the wire harness.**

Measure the resistance of the positive lead with a multimeter.

- If the multimeter registers zero resistance : There is continuity.
- If the multimeter registers infinite resistance : There is no continuity.

Measure the resistance of the negative lead with a multimeter.

- If the multimeter registers zero resistance : There is continuity.
- If the multimeter registers infinite resistance : There is no continuity.

If the wire harness is not in the state above, replace it with a new one.

3. If the above procedure does not solve the problem, inspect the control board.

10-6 Sharpen the Cutter

File and reshape the cutter edges as shown.

- (A) 8.0 mm (0.31 in) radius
- (B) 100 degree (approx.)
- (C) 45 degree
- (D) 35 degree

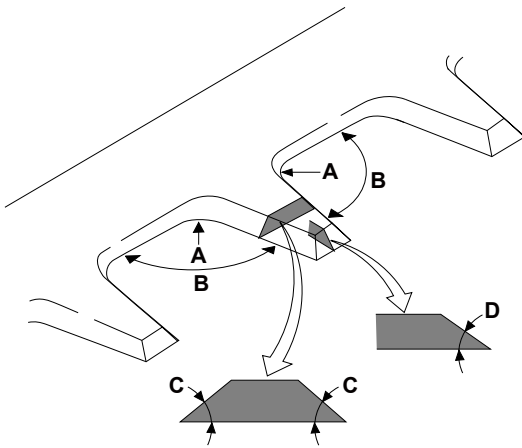

Prerequisites

- Remove the battery.
- Prepare eye protection and safety gloves.

CAUTION

- Wear eye protection and safety gloves when sharpening the cutters to protect your eyes and hands from injury.

- Required tools and materials:
 - Disk grinder, Abrasive belt, or Smooth flat file
 - Blade Lubricant

Procedure

1. Move the cutter position to 2 - 3 mm as shown.

2. Sharpen the cutter faces as shown.

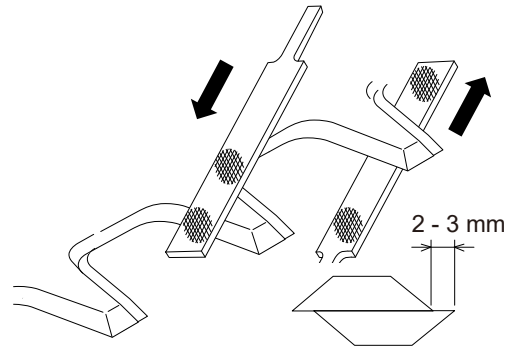

NOTICE

- Sharpen the base of the cutters smoothly as shown.

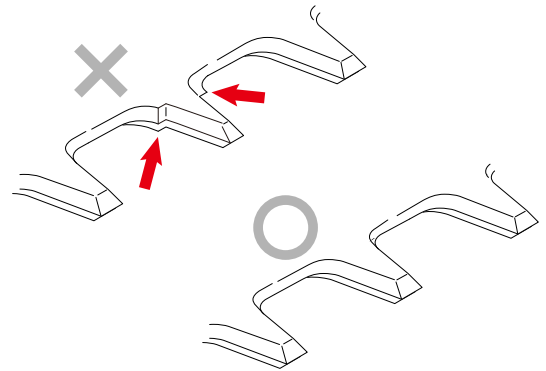

3. Move the cutter position to 2 - 3 mm as shown.
4. Sharpen the cutter faces as shown.

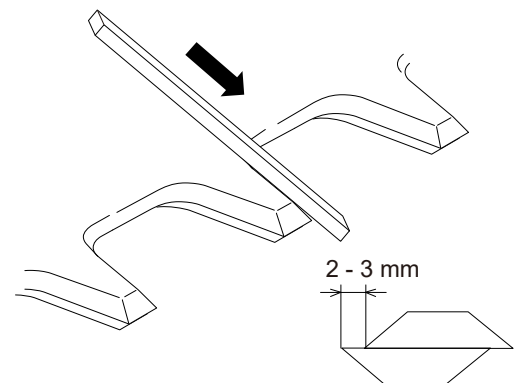

5. Sharpen the cutter faces as shown.

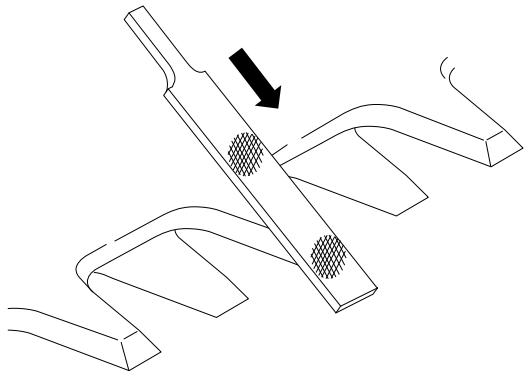

Related Topics

- [8-2 Remove the Cutter Assembly \(p.68\)](#)
- [8-3 Attach the Cutter Assembly \(p.68\)](#)
- [8-1 Cutter Components \(p.67\)](#)

YAMABIKO