

# COBRA

MODELS: T60RL (DYM7603)

## COBRA CULTIVATOR / TILLER OWNER'S MANUAL



**Cobra Garden Machinery**

Henton and Chattell Ltd., London Road, Nottingham NG2 3HW UK

[www.cobragarden.co.uk](http://www.cobragarden.co.uk)

## CONTENTS

SECTION 1 SAFETY LABELS .....	3
SECTION 2 SAFETY INSTRUCTION.....	4
SECTION 3 COMPONENTS .....	6
SECTION 4 TECHNICAL DATA.....	7
SECTION 5 ASSEMBLY .....	7
SECTION 6 CONTROLS.....	10
SECTION 7 BEFORE OPERATION.....	12
SECTION 8 OPERATION.....	12
SECTION 9 SERVICING.....	15
SECTION 10 STORAGE.....	18
SECTION 11 TRANSPORTING.....	18
SECTION 12 WARRANTY.....	19
SECTION 13 EC-DECLARATION OF CONFORMITY.....	20

## 1. SAFETY LABELS

The following safety labels appear on the machine. They are there to remind you of the care and attention required in use. This is what the symbols mean:



Read Operator's Manual



Danger! Rotating work machine.



When repairing, please pick up the spark plug, and then repair it according to the operational manual.



Keep Bystanders Away



Fuel is flammable, keep fire away. Do not add fuel with running machine.



Toxic fumes; don't operate inside house.



When working, please wear the glasses and ear plugs to defend the operator himself.



Caution: Engine hot.

## 2. SAFETY INSTRUCTION

**!WARNING:** When using petrol tools, basic safety precautions, including the following, should always be followed to reduce the risk of serious personal injury and/or damage to the unit. Read all these instructions before operating this product and retain these instructions for future reference.

**!WARNING:** This machine produces an electromagnetic field during operation. This field may under some circumstances interfere with active or passive medical implants. To reduce the risk of serious or fatal injury, we recommend persons with medical implants to consult their physician and the medical implant manufacturer before operating this machine.

### Training

1. Before using the tiller read the instructions carefully. Familiarise yourself with the controls and pay particular attention in learning how to stop the machine in an emergency.
2. Never allow children or people unfamiliar with these instructions to use the tiller. Local regulations can restrict the age of the operator.
3. Never operate while people, especially children or pets are nearby.
4. Never use the tiller if the operator is taking medicine or substances that could affect or impair his ability to react or concentrate.
5. Keep in mind that the operator or user is responsible for accidents or hazards occurring to other people or their property.

### Before you start

1. While operating the tiller, always wear substantial footwear and long trousers. Do not operate the equipment when barefoot or wearing open toed sandals.
2. Thoroughly inspect the area where the equipment is to be used and remove all objects which can damage or be thrown by the machine.
3. WARNING - Petrol is highly flammable.
  - Store fuel in containers specifically designed for this purpose.
  - Refuel outdoors only and do not smoke while refuelling; add fuel before starting the engine.
  - Never remove the cap of the fuel tank or add petrol while the engine is running or when the engine is hot.
  - If petrol is spilled, do not attempt to start the engine, but move the machine away from the area of spillage and avoid creating any source of ignition until petrol vapours have dissipated.
  - Replace all fuel tank and container caps securely.
4. Replace faulty silencers.
5. Before using, always visually inspect to see that the blade, blade bolts and cutter assembly are not worn or damaged. Replace worn or damaged blades and bolts in sets to preserve balance.

### Operation and Caution

1. Do not operate the engine in a confined space where dangerous carbon monoxide fumes can

collect, refuel outdoors only.

2. Operate only in daylight or in good artificial light.
3. Avoid operating the equipment in wet conditions, where feasible.
4. Always be sure of your footing on slopes.
5. Walk, never run, always be in control of the tiller and never allow yourself to be pulled along.
6. Exercise extreme caution when changing direction on slopes.
7. Do not operate on excessively steep slopes of more than 20°
8. Use extreme caution when reversing or pulling the tiller towards you.
9. Never operate the tiller with defective guards, covers or without safety devices in place.
10. Do not change the engine governor settings or over speed the engine.
11. Before starting the engine disengage the cultivator blade and drive clutches.
12. Keep your feet well away from the blade when starting the engine and in accordance with the instructions.
13. Do not tilt the tiller when starting the engine and always start on a flat surface.
14. Never put hands or feet near or under rotating parts.
15. Always ensure the engine is fully switched off before picking up/carrying the tiller.
16. Stop the engine and disconnect the spark plug wire, make sure that all moving parts have come to a complete stop and, where a key is fitted remove the key, make sure engine has had time to cool.
  - Before clearing the cultivator tines / blades
  - Before checking, cleaning or working on the tiller.
  - After striking a foreign object. Inspect the tiller for damage and make repairs before restarting.
  - If the tiller starts to vibrate abnormally (check immediately).
17. Stop the engine and disconnect the spark plug wire, make sure that all moving parts have come to a complete stop and, where a key is fitted remove the key, make sure engine is completely cooled.
  - Whenever you leave the tiller.
  - Before refuelling.
18. Reduce the throttle setting during engine shut down and, if the engine is provided with a shut-off valve, turn the fuel valve off.

### Maintenance and Storage

1. Keep all nuts, bolts and screws tight to be sure the equipment is in safe working condition.
2. Never store the equipment with petrol in the tank inside a building where fuel vapours can reach an open flame or spark or where the temperature is high.
3. Before storage allow the engine to cool.
4. To reduce the fire hazard, keep the engine, silencer, battery compartment and petrol storage area free of grass, leaves, or excessive grease.
6. Replace worn or damaged parts for safety. Genuine parts should always be used as parts of inferior quality can damage the equipment and compromise safety.
7. If the fuel tank has to be drained, this should be done outdoors. Always ensure engine is completely cooled before starting this task.
8. If the cultivator blades/tines needs to be removed, wear strong gloves to prevent injury to hands and fingers.
9. When transporting the machine make sure you close the fuel cut off. Be careful to ensure weight is evenly distributed. Wear strong gloves.
10. When tilting the machine never tilt towards the air filter as this may become damaged with fuel.

11. Never crank the engine when the spark plug is removed.
12. Frequently check the fuel lines and fittings for damage and cracks, replace if necessary
13. Never start the engine with the air filter cover removed.
14. Carefully clean the tiller after use to remove debris as this can damage and corrode.

**⚠ Warning: Do not touch rotating tines/blade.**

**⚠ Warning: Refuel in a well ventilated area with the engine stopped**

### 3. COMPONENTS

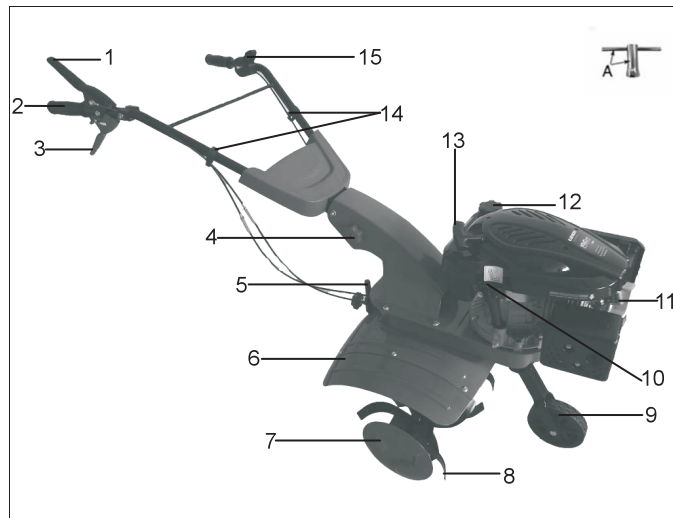

Fig. 1

- |                  |                     |                    |                 |                    |
|------------------|---------------------|--------------------|-----------------|--------------------|
| 1. Clutch handle | 2. Handle           | 3. Reverse handle  | 4. Locking knob | 5. Depth regulator |
| 6. Fender        | 7. Protective Plate | 8. Blade           | 9. Front wheel  | 10. Oil cap        |
| 11. Spark plug   | 12. Fuel cap        | 13. Starter handle | 14. Cable clamp | 15. Choke lever    |

**Including** A. Spark plug wrench

### 4. TECHNICAL DATA

Type	T60RL (DYM7603)
Engine	LC1P70FC
Engine displacement	196 cm <sup>3</sup>
Rated engine power	3.1kW
Blade width	600mm
Blade diameter	280mm
Fuel capacity	1.0 L
Max.engine speed	3200/min
Net weight	48.6kg
Sound pressure level at operator's position (According to EN 709)	81.9dB(A) K=3 dB(A)
Measured Sound power level LWA, (According to EN 709)	95.20 dB(A), K=2.22 dB(A)
Guaranteed Sound Power level (According to 2000/14/EC)	97dB(A)
Vibration(According to EN 709)	6.433m/s <sup>2</sup> , K=1.5m/s <sup>2</sup>

### 5. ASSEMBLY

#### 5.1 ASSEMBLE THE BLADE

1. Connect the right blade assembly as shown Fig. 2A/ Fig. 2B.
2. Align the hole of the shaft. (Fig.2C)
3. Fix the blade assembly with the bolt and fixed pin. (Fig. 2D/ Fig. 2E)
4. Assemble the left blade in the same way.

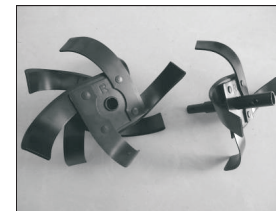

Fig. 2A

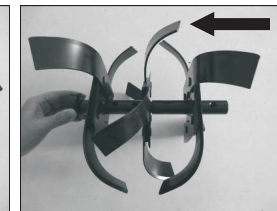

Fig. 2B

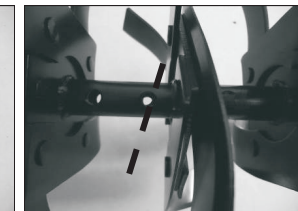

Fig. 2C

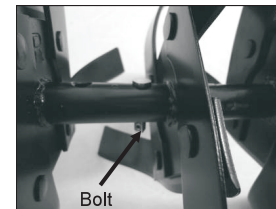

Fig. 2D

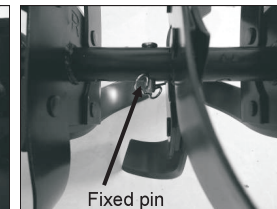

Fig.2E

## 5.2 ASSEMBLE THE PROTECTIVE PLATE

1. Insert the right protective plate into the blade assembly (Fig. 3A/ Fig. 3B).
2. Align the hole of the shaft. (Fig.3C)
3. Fix the blade and protective plate with bolt and fixed pin. (Fig. 3D/ Fig. 3E)
4. Assemble the left protective plate in the same way.

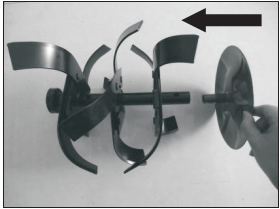

Fig. 3A

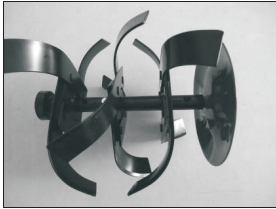

Fig. 3B

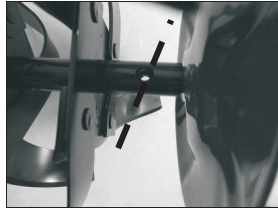

Fig.3C

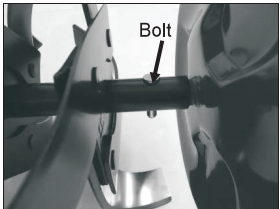

Fig.3D

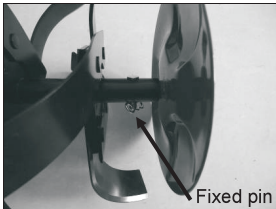

Fig.3E

## 5.3 ASSEMBLE THE BLADE TO THE UNIT

1. Insert the right blade assembly into the transmission shaft (Fig. 4A/ Fig. 4B).
2. Align the hole of the shaft. (Fig.4C)
3. Fix the blade with bolt and fixed pin. (Fig. 4D/ Fig. 4E)
4. Assemble the left blade in the same way.

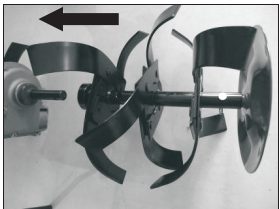

Fig. 4A



Fig. 4B



Fig.4C

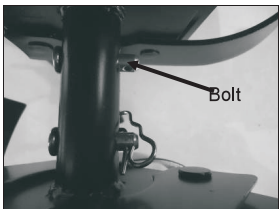

Fig. 4D

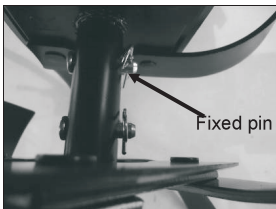

Fig. 4E

Fig.4D

Fig.4E

## 5.4 ASSEMBLE THE FRONT WHEEL

1. Insert the bushing into the hole of front wheel. (Fig. 5A/ Fig. 5B)
2. Fix the front wheel into place with bolt and nut. (Fig. 5C/ Fig. 5D)

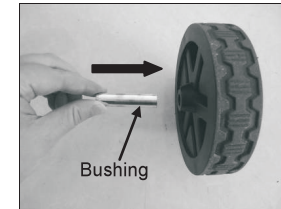

Fig. 5A

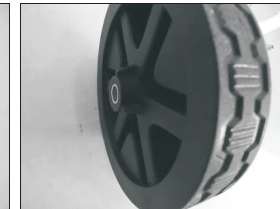

Fig. 5B

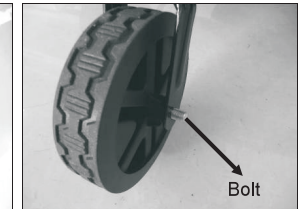

Fig. 5C

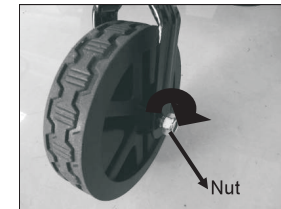

Fig. 5D

## 5.5 ASSEMBLE THE FENDER

1. Fix the fender into the unit body with bolts and nuts. (Fig. 6A/ Fig. 6B)
2. Fix the other fender in the same way.

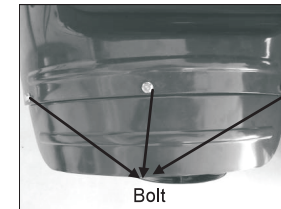

Fig. 6A

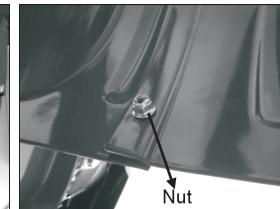

Fig. 6B

## 5.6 ASSEMBLE THE HANDLE

1. Fix the handle panel with screws and washers. (Fig. 7A/ Fig. 7B)
2. Fix the handle into the unit body with bolt and nut (Fig. 7C/ Fig. 7D/ Fig. 7E/ Fig. 7F)



Fig. 7A



Fig. 7B



Fig. 7C

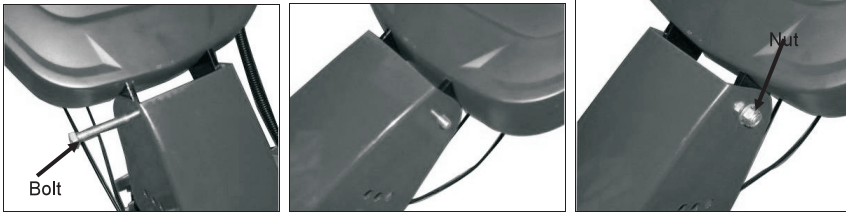

Fig.7D

Fig.7E

Fig.7F

### 5.7 ADJUSTMENT OF THE HANDLE HEIGHT

1. Move the handle up or down, adjustment it to the correct height. There are 3 adjustment heights on this type of petrol cultivator; The 3rd position the handle to the ground is highest, the 1st position is the lowest.
2. Fix the handle with the bolts and locking knobs. The bolts and locking knobs should be in the same height on both sides. (Fig. 8A/ Fig. 8B/ Fig. 8C)
3. Attach the cable-clamp to the position shown and then attach the cable. (Fig. 8D)

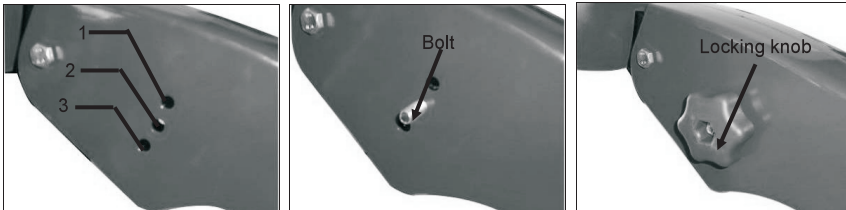

Fig. 8A

Fig. 8B

Fig. 8C

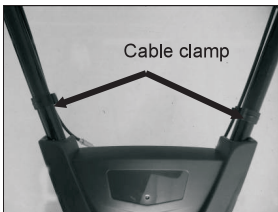

Fig. 8D

## 6. CONTROLS

### 6.1 ENGINE SWITCH

The engine switch enables and disables the ignition system.

The engine switch must be in the "START RUN" position when starting the engine.

Turn the switch to the "STOP O" position to stops the engine.( Fig. 9)



Fig.9

### 6.2 THROTTLE CHOKE LEVER

The throttle lever controls engine speed.

When starting the engine turn the throttle choke lever to '🐦' position. (Fig. 10)

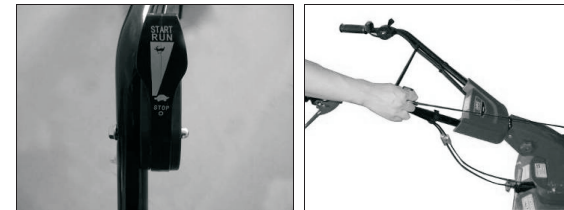

Fig. 10

Fig. 11

### 6.3 RECOIL STARTER GRIP

Pulling the starter grip operates the recoil starter to crank the engine. (Fig. 11)

Fig. 11

### 6.4 CLUTCH HANDLE AND REVERSE HANDLE

This is situated on the right handle. Connect the worm bar and engine output shaft to drive the cultivator blade when the clutch handle is press down.

1. Press the lock button (1) whilst pressing down the clutch handle (2) and keep it held, the machine will move forward. (Fig. 12A/ Fig. 12B)

Release the clutch handle to stop the machine moving.

2. Press the lock button (1) and Press down the reverse handle (2) and keep it held, the machine will reverse automatically. (Fig. 12C/ Fig. 12B)

Release the reverse handle, the petrol cultivator will stop reversing.

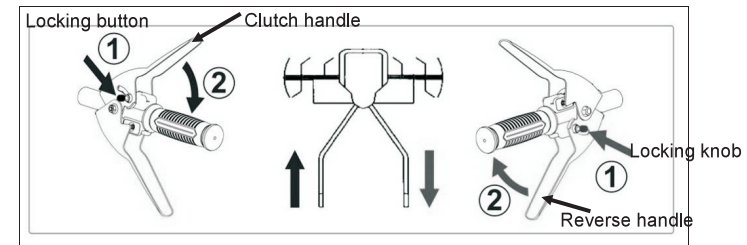

Fig. 12A

Fig. 12B

Fig. 12C

## 6.5 ADJUSTMENT OF THE DEPTH REGULATOR

1. Loosen the locking knob. (Fig. 13)
2. Align the hole on the regulator and adjustment the depth (4 positions). The deepest position (position 1), the shallowest position (position 4). (Fig. 13)
3. Tighten the locking knob.

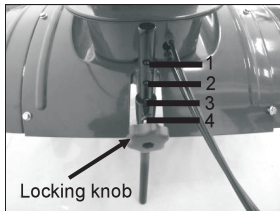

Fig. 13

## 7. BEFORE OPERATION

### 7.1 CHECK THE GENERAL CONDITION

Look around and underneath of the engine for signs of oil or gasoline leaks.

Remove any excessive dirt or debris, especially around the exhaust and recoil starter.

Look for signs of damage.

Check that all shields and covers are in place, and all nuts, bolts, and screws are tightened.

### 7.2 CHECK THE ENGINE

Check the oil level. (see 9.5)

**Please Note:** For shipping purposes, there is no fuel and oil in the engine.

Fill the engine with oil before using.

Check the air filter. (see 9.9)

Check the fuel level. (see 9.4)

**NOTICE:** The engine can be seriously damaged without oil. Always check the oil level before using. The machine must stand on level ground when checking.

## 8. OPERATION

**⚠ CAUTION:** The petrol cultivator is equipped with fenders. The petrol cultivator may never be started without it or with a defect fender.

### 8.1 STARTING THE ENGINE

1. The unit is equipped with a rubber boot over the end of the spark plug, make certain the metal loop on the end of the spark plug wire (inside the rubber boot) is fastened securely over the metal tip on the spark plug.

2. When starting the engine, turn the throttle choke lever to “” position, (Fig. 14A)
3. Standing behind the unit, pull the starter grip lightly until you feel resistance then pull briskly. Return the starter grip gently. Once the engine starts, set the throttle lever on a suitable position. (Fig. 14B)

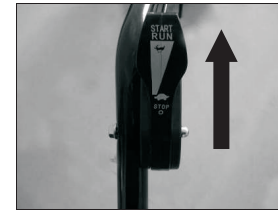

Fig. 14A

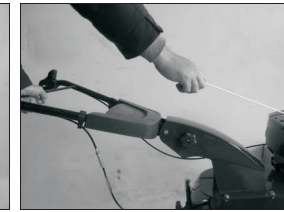

Fig. 14B

### 8.2 STOPPING THE ENGINE

To stop the engine in an emergency or normal condition, simply press the handle switch to the “STOP O” position. (Fig. 14C)

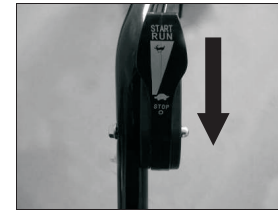

Fig. 14C

### 8.3 OPERATE THE MACHINE

1. Pull the front wheel support of the petrol cultivator with one hand for downward and moved to the slot. (Fig. 15A/ Fig. 15B)
  2. Start the engine as above. Let the engine run a few minutes to warm up before use.
  3. Press the lock button (1) and meanwhile press down the clutch handle (2) and keep it held, the machine will move forward. (Fig. 15C)
  4. Press the lock button (1) and Press down the reverse handle (2) and keep it in grasp, the machine will reverse automatically. (Fig. 15D)
- Release the clutch handle to stop the machine to moving.  
Release the reverse handle, the petrol cultivator will stop reversing.

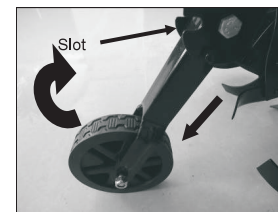

Fig. 15A



Fig. 15B

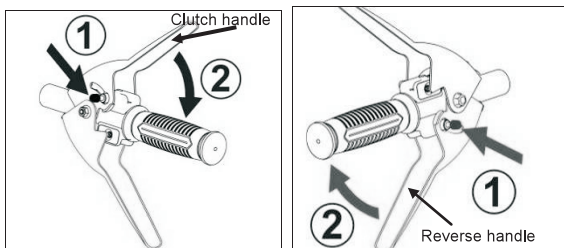

Fig. 15C

Fig. 15D

**⚠ WARNING:** If the soil is stuck on the cultivator blades, do not try to remove it before:

- Releasing the clutch handle.
- Stopping the engine.
- Disconnecting the spark plug cable.
- Waiting up to 30 minutes after use to allow the engine to cool.
- Do not put your hand inside the cultivator blade.

#### 8.4 ADJUSTING THE WIRE

##### Forward drive mode

When the drive starts feeling slow you need to adjust the clutch wire.

- Finely adjust the wire using the adjustment screw.
- To tension the wire and increase speed, screw the adjustment screw clockwise.

Make sure the wires are not tensioned too tight, if the cultivator starts to drive without the clutch lever being operated, extend the wire.

- To extend the wire and reduce speed, screw the adjustment screw counterclockwise (Fig.16)

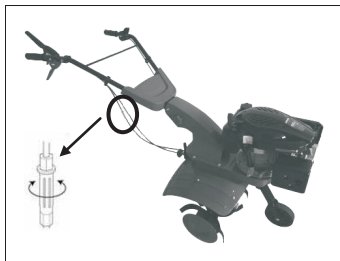

Fig.16

##### Reverse drive mode

When the drive starts feeling slow you need to adjust the reverse control wire.

- Finely adjust the wire using the adjustment screw.
- To tension the wire and increase speed, screw the adjustment screw clockwise.

Make sure the wires are not tensioned too tight, if the cultivator starts to drive without the reverse lever being operated, extend the wire.

- To extend the wire and reduce speed, screw the adjustment screw counterclockwise (Fig.16)

#### 8.5 AFTER USE

1. Check for loose or damaged parts. If required, change damaged parts.
2. Tighten loose screws and nuts.
3. Clean both cultivator blades.
4. Disconnect the spark plug cable.

#### 9. SERVICING

##### 9.1 SAFETY PRECAUTIONS

Make sure the engine is off before you begin any maintenance or repair. This will eliminate several potential hazards:

- Carbon monoxide poisoning from engine exhaust.

Never run the machine indoors. The exhaust fumes contain carbon monoxide, a very toxic gas.

- Burns from hot parts.

Let the engine cool for up to 30 minutes after use before touching.

- Injury from moving parts.

Read the instructions before you begin, and make sure you have the tools and skills required.

To reduce the possibility of fire or explosion, be careful when working around petrol. Use only a nonflammable solvent, not petrol, to clean parts. Keep cigarettes, sparks and flames away from all fuel related parts.

##### 9.2 MAINTENANCE SCHEDULE

REGULAR SERVICE PERIOD		Each use	First month or 20 Hrs.	Every 3 months or 50 Hrs.	Every 6 months or 100 Hrs.	Every year or 300 Hrs.
ITEM						
● Engine oil	Check level	○				
	Change		○		○	
● Air cleaner	Check	○				
	Clean			○(1)		
	Replace					○*
● Sediment Cup	Clean				○	
● Spark Plug	Check-Clean				○	
	Replace					○
Spark arrester (optional parts)	Clean				○	
● Idle speed	Check-Adjust					○(2)
● Valve clearance	Check-Adjust					○(2)
● Fuel tank and Strainer	Clean					○(2)
● Combustion chamber	Clean	After every 300 Hrs.(2)				
● Fuel line	Check	Every 2 years (replace if necessary )(2)				

- Emission-relate items.

\* Replace the paper element type only.

(1) Service mote frequently when used in dusty areas.

(2) These items should be serviced by your servicing dealer unless you have the proper tools and are



mechanically proficient. Refer to manual for service procedures.

### 9.3 REFUELING

Use unleaded petrol to produces fewer engine and spark plug deposits and extends exhaust system life.

**⚠ WARNING:** petrol is highly flammable and explosive, and you can be burned or seriously injured when refueling.

- Stop engine and keep heat, sparks, and flame away.
- Refuel only outdoors.
- Petrol is poisonous, be careful not to touch or breathe the vapors.

### 9.4 ADDING FUEL

9.4.1 Remove the fuel tank cap.

9.4.2 Add fuel to the bottom of the fuel level limit in the neck of the fuel tank. Do not overfill. Wipe up spilled fuel before starting the tiller.

### 9.5 ENGINE OIL LEVEL CHECK

9.5.1 Check the oil with engine stopped and level.

9.5.2 Remove the oil filler cap/dipstick and wipe it clean.

9.5.3 Insert the oil filler cap/dipstick into the oil filler neck as shown, but do not screw it in, then remove it to check the oil level. (Fig. 17A)

9.5.4 If the oil level is near or below the lower limit mark on the dipstick, remove the oil filler cap/dipstick, and fill with the recommended oil to the upper limit mark. Do not overfill. (Fig. 17B)

9.5.5 Reinstall the oil filler cap/dipstick.

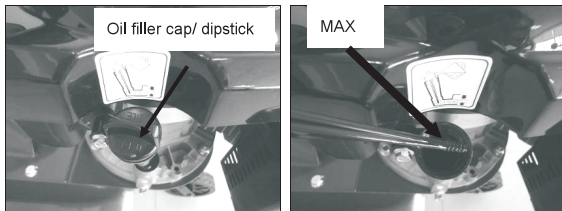

Fig. 17A

Fig. 17B

### 9.6 ENGINE OIL RECOMMENDATIONS

SAE 10W-30 is recommended for general use. Other viscosities shown in the chart may be used when the average temperature in your area is within the recommended range.

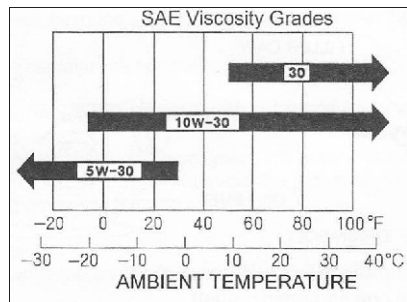

Fig.18

The SAE oil viscosity and service classification are in the API label on the oil container. We recommend

that you use API SERVICE Category SE or SF oil.

### 9.7 OIL CHANGE

Drain the engine oil when the engine is warm. Warm oil drains quickly and completely.

1. Place a suitable container below the engine to catch the used oil.
2. Remove the drain bolt. Remove the oil into the container by slightly tipping the engine toward the oil filler cap/dipstick. Re-assemble the drain bolt after changing.
3. With the engine in a level position, fill to the upper limit mark on the dipstick with the recommended oil.
4. Reinstall the oil filler cap/dipstick securely.

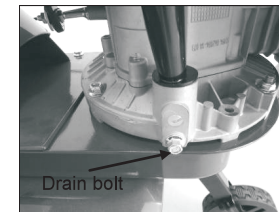

Fig. 19

**⚠ WARNING:** Running the engine with a low oil level can cause engine damage.

- Engine oil is poisonous, be careful not to touch it.
- With engine off but still warm, disconnect the spark plug wire and keep it away from the spark plug. We suggest you take used oil in a sealed container to your local recycling center or service station for reclamation. Do not throw it in the trash, pour it on the ground, or down a drain.

### 9.8 LUBRICATION

**⚠ WARNING:** No service must be carried out before: The engine has stopped.

The cable has been disconnected from the spark plug.

Lubricate the linkage every 10 hours of use and before long time storage. Use 10W oil.

No parts inside the gearbox are to be lubricated. All bearings and bushings are permanently lubricated and require no maintenance.

Lubricating these parts will only result in the grease getting on to the friction wheel and disc drive plate, which could damage the rubber clad friction wheel.

For long time storage the above-mentioned parts should be lightly wiped with an oily rag to prevent rust.

### 9.9 AIR CLEANER SERVICE

A dirty air filter will restrict air flow to the carburetor, reducing engine performance. If you operate the engine in very dusty areas, clean the air filter more often than specified in the **MAINTENANCE SCHEDULE**.

**⚠ NOTICE:** Operating the engine without an air filter, or with a damaged air filter, will allow dirt to enter the engine, causing rapid engine wear.

**⚠ CAUTION:** Do not hose engine. Water can damage engine or contaminate the fuel system.

1. Wipe the body of the tiller with a dry cloth.
2. Hose the tines and guards by tilting so that the spark plug is up.

### 9.10 ENGINE AIR CLEANER

**CAUTION:** Do not allow dirt or dust to clog the air filter foam element. The engine air cleaner element must be serviced or replaced after 50 hours normal use. Replace more regularly if used in dry dusty conditions.

## TO REPLACE THE AIR FILTER

1. Press down the two tabs on top of the filter cover. (Fig.19A)
2. Remove the cover. (Fig.19B)
3. To loosen debris, gently tap the filter on a hard face. If the filter is excessively dirty, replace with a new filter.
4. Reinstall filter.
5. Close the filter cover.

**NOTE:** Replace filter if frayed, torn, damaged or unable to be cleaned.

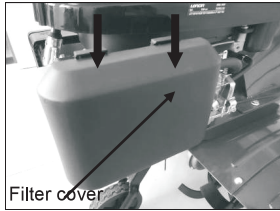

Fig.20A

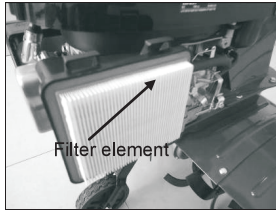

Fig.20B

## 10. STORAGE

Never store the machine with petrol in the fuel tank in a confined area with bad ventilation. Petrol fumes could reach open flames, sparks and cigarettes etc.

If the machine is to be stored for a longer period than 30 days, the following method are recommended.

1. Empty the fuel tank.
2. Start the engine and let it run until it stops due to lack of fuel.
3. Change the engine oil if it has not been done for 3 months.
4. Remove the spark plug and empty a little engine oil in the hole. Crank the engine a couple of times.  
Screw back the spark plug.
5. Clean the whole machine thoroughly.
6. Lubricate all the parts as shown in LUBRICATING above.
7. Inspect the machine for damage, repair if necessary.
8. Touch up any paint damage.
9. Rust protection to the metal surfaces.
10. Store the machine indoors if possible.

## 11. TRANSPORTING

If the engine has been running, allow it to cool for at least 15 minutes before loading the machine on the transport vehicle. A hot engine and exhaust system can burn you and can ignite some materials.

Empty the fuel tank before transporting.

## 12. WARRANTY

This product is warranted in accordance with legal regulations for a 24 month period effective from the date of purchase by the first user.

This product will not be covered if used in a commercial application.

This warranty covers all material or production failures, it does not include: defects from normal wear and tear, parts such as, bearings, brushes, cables, air cleaning elements, brake pad, clutch disc, tyre, wheel, recoil starter rope, belts, cutter blades, plugs, lubricant oils and grease or accessories. Damage or defects resulting from abuse, accidents or alterations, natural fading of painted or plated surfaces, sheet peeling and other natural deterioration.

Any damage that occurs from the use of non-genuine Cobra parts will not be covered.

We reserve the right to reject any claim where the purchase cannot be verified or when it is clear that the product was not maintained properly. (Clean ventilation slots, carbon brushes and serviced regularly)

Expenses incidental to the warranty claim that are not covered;

-Compensation for loss of time, commercial loss or rental costs of substitute product.

-Costs incurred for transportation to and from the dealership.

Any damage that occurs from the following will not be covered; exposure of the product to smoke and soot, chemical agents, bird droppings or other animal waste, seawater, sea breeze, salt or other environmental phenomena.

Any damage resulting from operating methods other than those indicated in the owner's manual will not be covered.

Your purchase receipt must be kept as proof for date of purchase. Your un-dismantled tiller must be returned to your dealer in an acceptably clean state, accompanied by your proof of purchase.

### Please Register Your Cobra

If your dealer did not collect registration information from you, please take a few minutes and register your purchase with Cobra.

You can register by completing and mailing the registration card that should be in the box or by going online to:

[www.cobragarden.co.uk](http://www.cobragarden.co.uk) and clicking on Product Registration.

Before using the Cobra, all operators must read this manual.

### 13. EC-DECLARATION OF CONFORMITY

EC Declaration of Conformity	
We herewith declare,	Cobra Garden Machinery Henton & Chattell Ltd, London Road, Nottingham NG2 3HW United Kingdom
that the following machine complies with the appropriate basic safety and health requirements of the EC Directive based on its design and type, as brought into circulation by us.	
In case of alteration of the machine, not agreed upon by us, this declaration will lose its validity	
Machine Description:	Petrol Cultivator
Machine Type:	T60RL (DYM7603)
Displacement	196 cm <sup>3</sup>
Max, Cutting width	600mm
Measured sound power level:	95.20dB(A)
Guaranteed sound power level:	97dB(A)
Applicable EC Directives	2006/42/EC 2014/30/EU 2000/14/EC (EU)2016/1628
Applicable Harmonized Standards	EN 709 EN ISO 14982
Authorized Signature/Date	  Peter J. Chaloner 2019-10-08
Title of Signatory	Managing Director
Name and address of the person authorized to compile the technical file	Cobra Garden Machinery Henton & Chattell Ltd, London Road, Nottingham NG2 3HW United Kingdom