

**HYUNDAI**  
POWER PRODUCTS

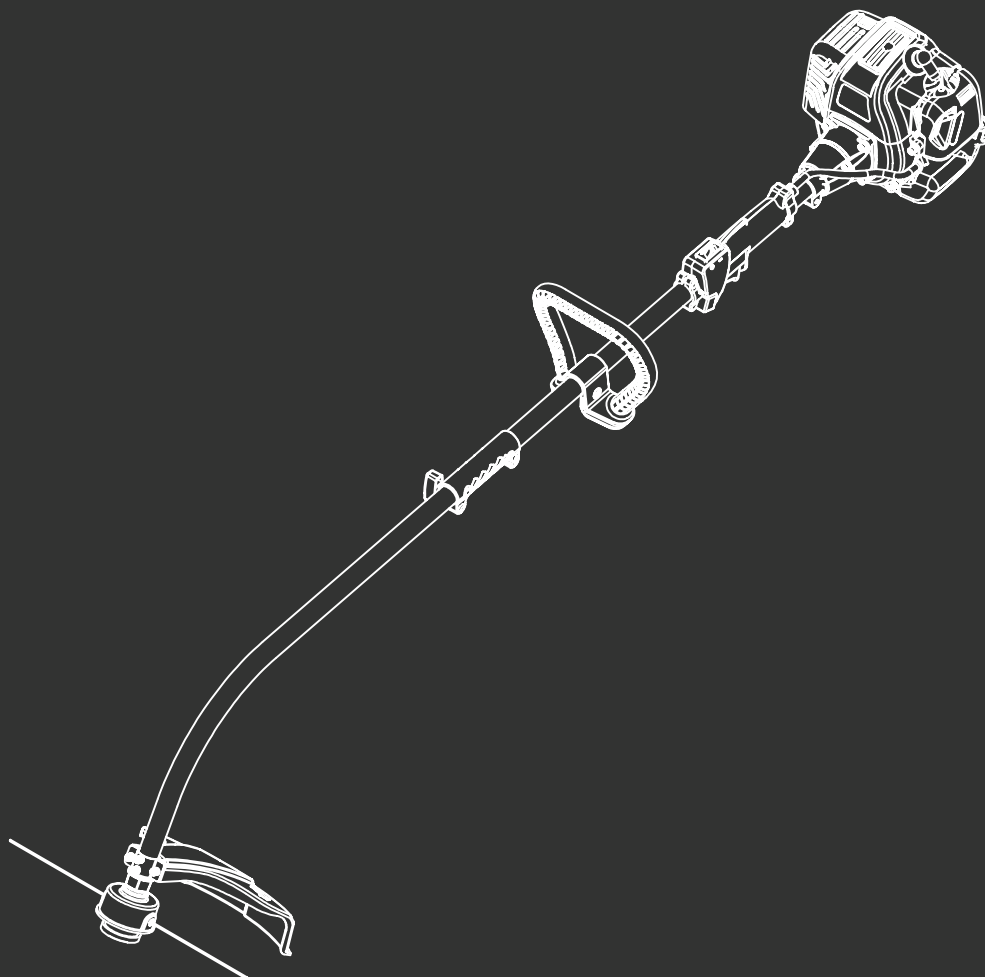

# GRASS TRIMMER HYTR2600X

Instruction Manual



# HYUNDAI POWER PRODUCTS

## Thank You For Purchasing Your HYUNDAI Product

We work very hard to give all of our customers the best possible service. If you have any problems, before leaving negative feedback, please contact us to give us a chance to resolve the issue.

We would be delighted if you left us positive feedback!  
Thank you for purchasing this product.

Rated **Excellent** on ★ Trustpilot

This manual has been produced by Hyundai Power Products and should be kept with the product. Please read and understand these instructions before you use your product. Failure to do this may result in personal injury or damage to the product.

The safety precautions and warnings are to ensure your safety and protect you from harm or damage to the product.

The information contained in this manual was accurate at the time of production, however HYUNDAI Power Products may make modifications to the product without notification.

GENPOWER LTD  
Isaac Way, London Road,  
Pembroke Dock, UNITED KINGDOM, SA72 4RW  
T: +44 (0) 1646 687 880 F: +44 (0) 1646 686 198  
E: info@hyundaipowerproducts.co.uk  
www.hyundaipowerproducts.co.uk

# Contents

Features.....	4-5
What's In The Box.....	5
General Safety.....	6-9
For Safe Operation.....	10-12
Symbols On The Machine.....	13
Assembly.....	14
Starting / Stopping Procedure.....	15
Using The Trimmer.....	16
Maintenance & Care.....	18-21
Troubleshooting.....	22-24
Specification.....	25
Disposal.....	26
Our Product Range.....	27
Useful Information.....	28
Notes.....	29
Contact Us.....	30
Declaration Of Conformity.....	31

**IMPORTANT: DON'T FORGET TO REGISTER YOUR EXTENDED  
3 YEAR HYUNDAI WARRANTY WITHIN 30 DAYS OF PURCHASE.  
<https://www.hyundaipowerproducts/warranty>**

## Contact Us



[www.hyundaipowerproducts.co.uk](http://www.hyundaipowerproducts.co.uk)



01646 687 880



[aftersales@hyundaipowerproducts.co.uk](mailto:aftersales@hyundaipowerproducts.co.uk)

# Features

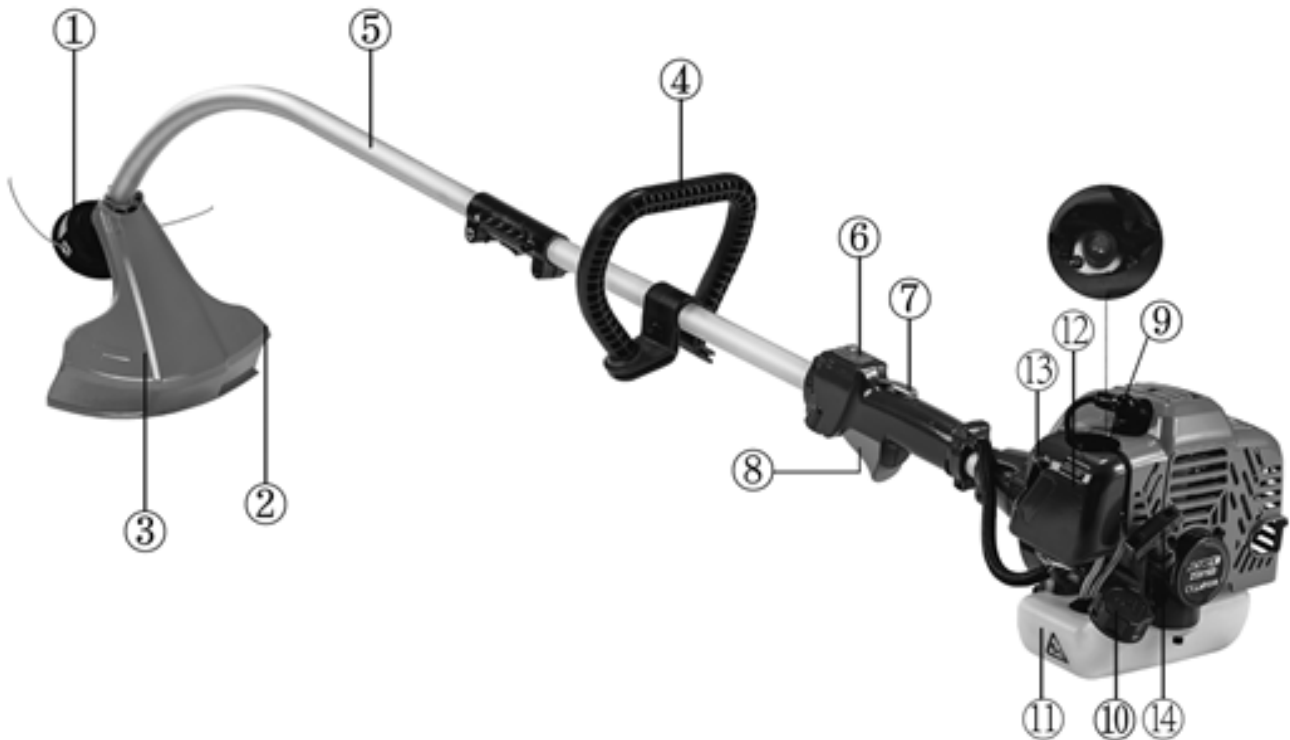

## 1 - Nylon Cutter Head

Contains replaceable nylon trimming line that advances when the trimmer head is tapped against the ground while the head is turning at normal operating speed.

## 2 - Cut-Off Knife

Trims nylon line to the correct length- 180mm/ 7" from the head to end of line. If trimmer is operated without a cut-off knife the line may become too long (more than 180mm/7") this will cause additional strain and may overheat or damage the engine.

## 3 - Debris Shield

Mounted just above the cutting attachment. Helps protect operator by deflecting debris produced during the trimming operation. Do not operate unit without shield.

## 4 - D-Handle

This handle can be adjusted and slid up or down the shaft to suit your preference.

## 5 - Lower Drive Shaft Assembly

Contains a specially designed liner with flexible drive shaft.

## 6 - Ignition Switch

Slide switch mounted on top of the throttle trigger housing. Move switch forward to run, back to stop.

# Features

## 7 - Safety Lever

Before using the throttle, push safety lever down.

## 8 - Throttle Trigger

Spring loaded to return to idle when released. When accelerating, press trigger gradually for best operating technique. Do not hold trigger while starting.

## 9 - Bulb

Pushing bulb (7 to 10 times before starting), will remove all air and stale fuel from fuel system and bring fresh fuel to the carburetor.

## 10 - Fuel Tank Lid

Ensure this is correctly and firmly threaded onto the tank when in use.

## 11 - Fuel Tank

Contains fuel and fuel filter.

## 12 - Air Cleaner Cover

Contains replaceable foam element.

## 13 - Choke

The choke (cold start) lever is located on the top of the filter cover.

## 14 - Starter Handle

Pull handle until engine starts, then return handle slowly. DO NOT let handle snap back or damage to starter will occur.

Specifications, descriptions and illustrative material in this manual are as accurate as known at the time of publication, but are subject to change without notice. Illustrations may include optional equipment and accessories, and may not include all standard equipment.

## What's In The Box

- Power unit
- Lower shaft
- Guard



# General Safety



**⚠ WARNING : READ THE INSTRUCTION BOOKLET THOROUGHLY BEFORE USING THE MACHINE.** Keep for future reference and pass it on if the machine is loaned or sold to another user.

## Training

### **⚠ DANGER ⚠**

Engine exhaust fumes contain Carbon Monoxide. This is a poisonous gas and can kill in minutes. NEVER use inside a building or in an area with poor ventilation.

**⚠ 1. WARNING!** You must read these instructions carefully before operating the machine. Make sure that you are familiar with the controls and properly operate the machine. You must learn how to stop the engine quickly. If you do not follow the warnings and instructions, it may result in fire and/or serious injury. Make sure to save all warnings and instructions for future reference.

**2.** Never allow children or people unfamiliar with these instructions to use the product. Local regulations can restrict the minimum age of the operator.

**3.** Never operate while people, especially children, or pets are nearby.

**4.** Never operate the product if the user is unwell or tired, or has taken alcohol, medicine, drugs or any substances which may slow the user's reflexes and compromise judgement.

**5.** Keep in mind that the operator or user is responsible for accidents, hazards or unexpected events involving the machine that occur to other people or their property. It is the responsibility of the user to assess the potential risk of the area where work is being

carried out. The operator or user must take all necessary precautions to ensure their own safety and that of others, especially on slopes or rough, slippery and unstable ground.

**6.** If the product is sold or lent to others, you must make sure that the operator reads this manual. Keep this manual safe and pass it on to the new user.

## Preliminary Operations

**1.** Always wear anti-slip and resistant work footwear and long trousers while using the machine. Do not use the machine when barefoot or wearing open sandals. Do not wear chains, bracelets or clothing that is loose fitting or hanging ties or cords. Tie long hair back. Always wear protective earplugs.

**2.** Make sure you thoroughly inspect the entire work area and remove all objects and anything that could be thrown by the machine or could damage the engine or cutting unit (branches, stones, wire, toys, etc).

**⚠ 3. WARNING: DANGER!** Petrol is highly flammable.

- Make sure to store the fuel in special containers.

- Use a funnel to add fuel, only outdoors. Do not smoke during this and each time fuel is handled.

- Add fuel before starting the engine, never remove the fuel tank cap or add fuel whilst the engine is running or when it is hot.

- If you have spilled fuel, make sure you do not attempt to start the engine but move the

# General Safety

machine away from the area of spilled fuel and avoid creating any source of ignition until the fuel has evaporated and fuel vapours have dissipated.

- Make sure to always put the tank and fuel container caps back on and tighten well.

4. You must check the general condition of the machine before use.

 **5. WARNING** - The noise and vibration levels shown in these instructions are the maximum levels for use of the machine.

Lack of maintenance will have a significant influence on noise emissions and vibrations. It is necessary to take preventive steps to eliminate possible damage due to high levels of noise and stress from vibration. You must maintain the machine well, wear ear protection and take breaks from working.

Appropriate Personal Protective Equipment (PPE), **MUST** be worn at all times when operating or repairing the machine.



## GLOVES

Protective electrically non-conductive gloves are highly recommended when working.



## BOOTS

Non-skid heavy duty footwear are highly recommended when working.



## HEARING PROTECTION

Suitable safety hearing protection is recommended.



## EYE PROTECTION

Always wear safety glasses/goggles and/or face shields. Everyday eyeglasses have only impact resistant lenses; they are not safety glasses/goggles.



## CLOTHING

Do not wear loose clothing, gloves, scarfs, neckties or jewellery (rings, wrist watches), which can be caught in moving parts.



# General Safety



## General Fuel Safety

---



### CAUTION! ALL FUELS ARE FLAMMABLE

- Fire hazard - keep fuel away from all sources of ignition for example heaters, lamps, sparks from grinding or welding.
- DO NOT carry out hot work on tanks that have contained fuel.
- ALWAYS keep the work area tidy.
- ALWAYS clean up spills promptly using absorbent granules and a lidded bin.
- ALWAYS dispose of waste fuels correctly.



## Fueling / De-Fueling

---



### CAUTION! ALL FUELS ARE FLAMMABLE

- ALWAYS fuel and de-fuel in a well ventilated area outside of buildings.
- ALWAYS wear correct, suitable and fit for purpose Personal Protective Equipment (PPE), suggested items are but not limited to safety gloves, overalls.
- When fueling/de-fueling ALWAYS avoid inhaling fumes.
- When de-fueling ALWAYS use a proper fuel retriever.
- ALWAYS carry fuel in the correct and clearly marked container.
- Do not smoke whilst fueling / de-fueling or using the machine.
- Keep the handles of the machine free from oil and fuel.



## Electrical Safety (Where Applicable)

---

- Electricity can kill – NEVER work on LIVE/ENERGISED equipment.
- Prior to carrying out any maintenance work you MUST identify electrical isolation methods and isolate all electrical supplies.
- Prior to use and with all electrical supplies isolated, you MUST check all electrical cables, plugs and connectors for the following;
  - Are intact and have no signs of damage, to include but not limited to bare wires, chaffing, cuts and loose wiring.
  - If there are any signs of damage, the damaged item MUST be taken out of service until the damage has been repaired by an electrically competent person.
- All trailing cables should be routed so as not to cause any kind of trip hazard.
- NEVER work on or near electricity with wet hands, wet clothing and wet gloves.

## Batteries (Where Present)

---

Batteries present a risk if they become damaged by the possible leaking of electrolyte. This electrolyte is an acid and can cause serious burn injuries. Care should be taken when working on or near them. **NOTE** the electrolyte may be in a liquid or gel form.

Should you come in to contact with electrolyte you should;

- Remove all clothing contaminated with electrolyte. If you cannot remove then saturate them in water.
- Get medical assistance as soon as possible.



# General Safety

You must advise the medical staff of the type of acid.

- Lead/acid battery = dilute sulphuric acid.
- Nickel/cadmium = potassium hydroxide alkali electrolyte.
- Use fresh running water to wash off excess electrolyte, continue this until medical assistance arrives. Make sure that you do not move the electrolyte to another part of your body or face.
- If electrolyte comes in to contact with eyes the electrolyte needs to be immediately washed away with large amounts of water. Make sure that you do not wash the electrolyte to another part of your face or body.
- Gasses from charging batteries are highly flammable and explosive and great care should be taken to charge in well ventilated areas.



• There is an explosion risk if the battery terminals are short circuited, when connecting/disconnecting ALWAYS exercise great care so that the terminals or battery leads are NOT allowed to touch and cause a spark. ALWAYS use suitable insulated tools.

## Vibrations (Where Applicable)

• Prolonged use of hand held (operated) machines will cause the user to feel the effects of/from vibrations. These vibrations can lead to white finger (Raynaud's phenomenon) or carpal tunnel syndrome. This condition reduces the ability of the hand to feel and regulate temperature, causing numbness and heat sensations and may cause nerve damage and circulatory tissue death.

• Not all factors that lead to white finger disease are known, but cold weather, smoking and other diseases that affect blood vessels and blood circulation as well as large and long-lasting impact of shocks are considered factors in the formation of white finger. Note the following to reduce the risk of white finger and carpal tunnel syndrome;

- Wear gloves and keep your hands warm.
- Take regular breaks.
- All of the above precautions may help reduce the risk of white finger disease but not rule out the carpal tunnel syndrome. Long-term and regular users are therefore recommended to observe the condition of your hands and fingers. Seek medical attention immediately if any of the above symptoms should occur.

## Noise (Where Applicable)

• The operating noise of the machine can damage your hearing. Wear hearing protection such as earplugs or ear defenders to protect your hearing. Long-term and regular users are advised to have hearing checked regularly. Be especially vigilant and cautious when using ear protection because your ability to hear alarm warnings will be reduced.

• Noise emissions for this equipment is unavoidable. Carry out noisy work at approved times and for certain periods. Limit the working time to a minimum. For your personal protection and protection of people working nearby it is also advisable for them to wear hearing protection.



• See Certificate of Conformity section for Outdoor Noise declaration of conformity.

## Contact Us



[www.hyundaipowerproducts.co.uk](http://www.hyundaipowerproducts.co.uk)



01646 687 880



[aftersales@hyundaipowerproducts.co.uk](mailto:aftersales@hyundaipowerproducts.co.uk)

# For Safe Operation

## During Use

 **1.** Never operate the engine in a confined space where dangerous carbon monoxide fumes can develop. All ignition operations have to be effected in an open or well-ventilated area. Always remember that exhaust fumes are toxic.

Carbon monoxide is a colourless and odourless gas. Inhaling this gas can cause death as well as serious long term health problems such as brain damage.

The symptoms of carbon monoxide poisoning can include but are not limited to the following; Headaches, dizziness, nausea, breathlessness, collapsing or loss of consciousness.

Carbon monoxide poisoning symptoms are similar to flu, food poisoning, viral infections and simply tiredness. It is quite common for people to mistake this very dangerous poisoning for something else.

To avoid carbon monoxide poisoning **DO NOT** use Petrol/Diesel powered equipment inside any of the following; Home, garage, tent, camper van, mobile home, caravan or boat. This is not exhaustive and if you are in any doubt contact your dealer.

If you think you have or someone around you has been affected by carbon monoxide poisoning; Get them fresh air immediately, by leaving the affected area or by opening doors and windows. If safe and practical to do so make sure that the machine is turned off.

**DO NOT** enter a room you suspect of having carbon monoxide present – instead call the emergency services.

Contact a Doctor immediately or go to Hospital – let them know that you suspect carbon monoxide poisoning.

**DO NOT** use in an enclosed area or moving vehicle.

**2.** You must only work in daylight or with good artificial light in good visibility conditions. Keep people, children and animals away from the working area.

**3.** Make sure on slopes you have a steady foothold.

**4.** You must walk and never run whilst holding the machine.

**5.** You must pay special attention when approaching obstacles that could compromise visibility.

**6.** When using the machine near roads, pay attention to traffic.

**7.** You must be careful near ravines, ditches or embankments.

**8.** Follow the instructions to start the engine carefully.

**9.** Do not place your hands or feet near or under rotating parts.

**10.** Do not tamper with or disable safety systems.

**11.** Do not over-rev the engine or change the engine settings.

**12.** The engine parts get very hot when running, do not touch. Danger of burns.

**13.** Only use manufacturer-recommended attachments.

**14.** You must switch off the engine (making sure that all moving parts are stationary):

- When transporting the machine
- Whenever you leave the machine unattended
- Before clearing blockages
- Before cleaning, checking or working on the machine
- After striking a foreign object, you must inspect the machine for damage and make

# For Safe Operation

repairs before using it again.

**29. WARNING** - If something breaks or an accident happens whilst working, you must turn off the engine immediately and move the machine away to prevent further damage. If an accident happens with injuries or third parties are injured, carry out the first aid measures most suitable for the situation immediately and contact the medical authorities for any necessary health care. Carefully remove any debris that might cause damage or harm persons or animals should it not be seen.

**30.** Do not tamper with the safety features.

**31.** Inspect the area to be cut and remove all debris that could become entangled in the nylon cutting head. Also remove any objects that the unit may throw during cutting.

**32.** Never leave the machine unattended.

**33.** Do not overreach. Keep proper footing and balance at all times. Do not run the unit while standing on a ladder or on any other unstable footing location.

**34.** Keep hands and feet clear of the nylon cutting head while unit is in use.

**35.** Never touch the nylon cutting head when ever the engine is running. If it is necessary to adjust the protector or nylon cutting head, be sure to stop the engine and confirm that the nylon cutting head has stopped running.

**36.** The engine should be turned off when the machine is moved between work areas.

**37.** Be careful not to hit the nylon cutting head against stones, or the ground. Unreasonable rough operation will shorten the life of the machine as well as create an unsafe environment for yourself and those around you.

**38.** Pay attention to loosening and overheating of parts. If there is any abnormality of the machine, stop operation immediately and check the machine carefully. If necessary, have the machine serviced by a authorized dealer. Never continue to operate a machine which may be malfunctioning.

**39.** After the engine has stopped, the machine is still hot. Never place the machine in any places where there are flammable materials (dry grass, etc.), combustible gasses or combustible liquids.

**40.** If you slip or fall to the ground or into a hole, release the throttle lever immediately.

**41.** Do not use in poor weather conditions such as rain or thunder and lightning.

**42.** Be careful not to drop the machine or hit it against obstacles.

**43.** Before proceeding to adjust or repair the machine, be sure to stop the engine and detach the spark plug.

**44.** When the machine is placed in storage for a long time, drain fuel from the fuel tank and carburetor, clean the parts, move the machine to a safe place and confirm that the engine is cooled down.

**45.** Total face and head protection must be wear to prevent damage from plummet or branch.

**46. WARNING:** The cutter area is still dangerous while the machine is coasting to a stop.

**47.** If a stone or any other obstacle is hit, stop the engine and check the nylon cutting head. A broken or unbalanced nylon cutting head must never be used.

**48.** Never remove the guard. Serious injury to the operator or bystanders could result as well as damage to the machine.

Contact Us



[www.hyundaipowerproducts.co.uk](http://www.hyundaipowerproducts.co.uk)



01646 687 880



[aftersales@hyundaipowerproducts.co.uk](mailto:aftersales@hyundaipowerproducts.co.uk)

# For Safe Operation

Even when the tool is used as prescribed it is not possible to eliminate all residual risk factors. The following hazards may arise in connection with the tool's construction and design:

1. Damage to lungs if an effective dust mask is not worn.
2. Damage to hearing if effective hearing protection is not worn.
3. Health defects resulting from vibration emission if the power tool is being used over longer period of time or not adequately managed and properly maintained.

**WARNING!** This machine produces an electromagnetic field during operation. This field may under some circumstances interfere with active or passive medical implants. To reduce the risk of serious or fatal injury, we recommend persons with medical implants to consult their physician and the medical implant manufacturer before operating this machine.

## **WARNING!**

All trimmers and brush cutters can throw small stones, metal or small objects as well as the material being cut. Insist that persons in the RISK ZONE beyond the danger zone wear eye protection from thrown objects. If the unit must be used where there are unprotected people, operate at a low throttle speed to reduce the risk of thrown objects. No person except operator allowed inside the 15 meter radius danger zone. Eye, ear, face, foot, leg and body protection must be worn by the operator.

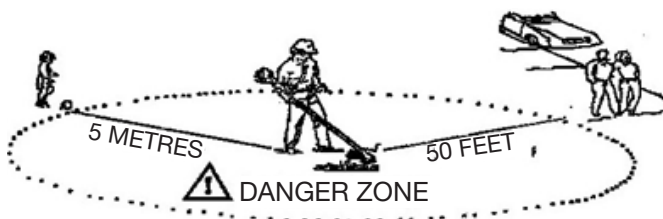

## Intended Use

The machine is intended for trimming grass, This machine may not be used to do other thing out of the described scope.

# Symbols On The Machine



**CAUTION!**  
Handle carefully.



**INSTRUCTION MANUAL**  
Read and understand operator's manual before using the machine. Failure to follow instructions could result in death or serious injury.



**DANGER!**  
Keep hands and feet away from cutting parts.



**GLOVES**  
Protective electrically non-conductive gloves are highly recommended when working.



**EYE PROTECTION**  
Always wear safety glasses/goggles and/or face shields. Everyday eyeglasses have only impact resistant lenses; they are not safety glasses/goggles.



**HEARING PROTECTION**  
Suitable safety hearing protection is recommended.



**BOOTS**  
Non-skid heavy duty footwear are highly recommended when working.



**WARNING**  
Beware of foot injury by cutting attachment.



**WARNING**  
Beware of thrown objects hit by cutting attachments. never use without properly mounted blade guard.

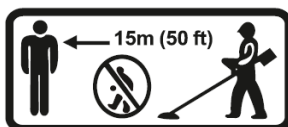

**KEEP AWAY**  
Keep 15m away from any other person.



**CE SYMBOL**  
This product complies with the applicable European directives and an evaluation method of conformity for these directives was done.



**WARNING!** Never modify a trimmer in any way. Improper use of the machine can cause serious or fatal personal injury.



# Assembly

## Getting Started

**CAUTION** - This guide is meant to serve as a quick reference for operating your HYUNDAI machine. We always advise reading the manual in full before operation.

**CAUTION** - For OUTDOOR use ONLY. Petrol machines produce carbon monoxide – a poisonous, colourless and odourless gas that can cause serious injury or death. Petrol is highly flammable, always handle with extreme care and in a well ventilated area.

**NOTE** - Images may vary depending on model.

**WARNING** - Unboxing and assembling the machine should be done on a flat, stable surface with enough room. Disposal of the packaging should be done in accordance with the local regulations in force.

## Assembly

### Handle Assembly

**NOTE** - The D-shaped Handle is attached to the shaft but has been rotated under for ease of packing.

1. Loosen adjustment knob and rotate handle to top of shaft. Position handle 165mm to 215mm 6-1/2 to 8-1/2" from throttle.

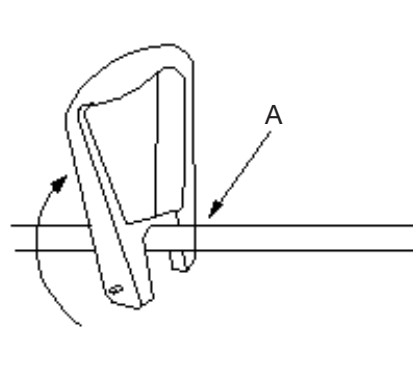

2. Tighten adjustment knob securely.

### Debris Shield

Shield Fits snug on shaft. Some force may be required.

1. Seat shield (B) onto shaft bracket (C).
2. Insert washers (D) onto bolt.
3. Insert bolt (E) and nut (F). Tighten securely.

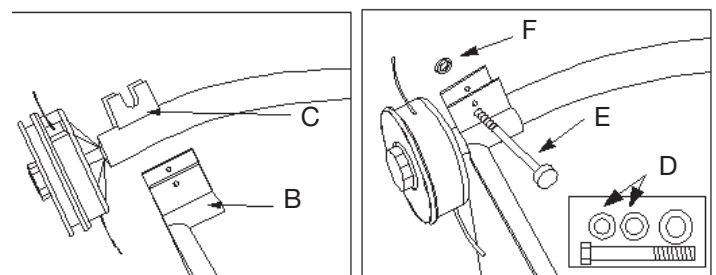

### Installing The Lower Shaft

1. Insert the lower aluminium tube into the upper connector, align the spring-loaded ball with the corresponding hole. Then turn the adjusting knob clockwise until it is tight.

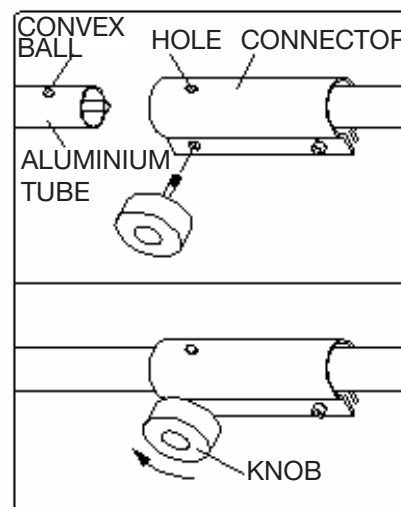

# Starting / Stopping Procedure

## Before Each Use

- Always ensure that the trimmer is in a safe working condition. Inspect the machine, check safety devices and guards and check all nuts, bolts and screws are secure.
- Check the oil and fuel level and check for fuel leaks.
- **CAUTION** - For OUTDOOR use ONLY. Petrol lawnmowers produce carbon monoxide – a poisonous, colourless and odourless gas that can cause serious injury or death. Petrol is highly flammable, always handle with extreme care and in a well ventilated area.
- Check the air cleaner is clean.
- Make sure the guard is securely in place.

 **Only start the trimmer on even ground. The ground must be free of foreign bodies, such as stones.**

## Starting Cold Engine

### STEP 1

Move the stop switch to 'START' position.

### STEP 2

Give a gentle push on the primer bulb repeatedly (7-10 times) until fuel comes into the primer pump.

### STEP 3

Pull lever up to close choke to 'START' position.

### STEP 4

Pull starter handle until engine attempts to start.

### STEP 5

Push the choke lever to 'RUN' position. (If fitted with an automatic choke, squeezing the throttle will reset the choke to 'RUN'). Excessive pulling with choke lever in 'START' position may cause flooding, making engine difficult to start.

### STEP 6

Pull starter handle until engine starts.

### STEP 7

Allow engine to warm up for a few minutes before using.

## Starting Warm Engine

If fuel tank was not run dry, pull starter one to three times and should start. **DO NOT USE CHOKE.**

If fuel tank was run dry of fuel, after refilling push choke lever to 'START' and repeat steps 3 - 7 in starting cold engine.

## After Each Use

- Examine the machine for damage.
- Clean the machine if necessary.

 **CAUTION - The engine will remain hot for a while after use. Ensure the machine has cooled before carrying out any maintenance or storage.**

## Stopping Procedure

### STEP 1

Move switch to 'STOP' position.

# Using The Trimmer

## Cutting With Nylon Head

For nearly all cutting, it is good to position the line head so that contact is made on the part of the cutting area where the line is moving away from the operator and the debris shield. (See appropriate).

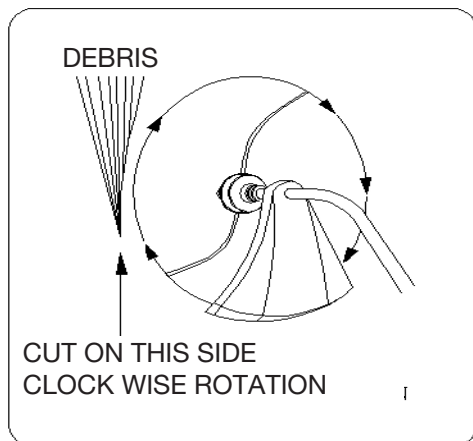

Line head rotates in a clockwise direction when looking from above. The cut off knife will be on the right side of the debris shield.

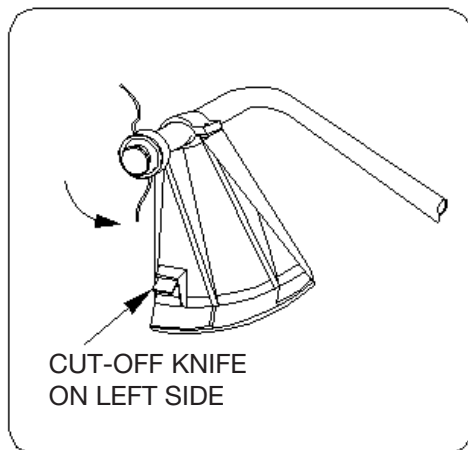

For nearly all cutting, it is good to tilt the line head so that contact is made on the part of the circle where the line is moving away from you and the debris shield. The results in the debris being thrown away from you.

### **! WARNING!**

Tilting the head to the wrong side will shoot the debris TOWARDS you. If the line head is held flat to the ground so that cutting occurs on the whole line circle, debris will be THROWN at you, The additional drag will slow the engine down, and you will use up a lot of line.

### **! WARNING!**

Use only quality nylon mono filament line of 2mm diameter, 3m in length. Never use wire or wire-reinforced line in place of nylon trimmer line. Load your nylon line cutting head only with nylon trimmer line.

### **! WARNING!**

The proper debris shield must be in place on the unit when nylon cutting line is used, The cutting line can flap around if too much line is exposed. Always use the plastic debris shield with cut-off blade when using nylon cutting head.

### **! WARNING!**

Use extreme caution when operating over bare spots and gravel, because the line can throw small rock particles at high speeds. Debris shields on the unit cannot stop objects which bounce or ricochet off hard surfaces.



# Using The Trimmer

## Trimming

This is feeding the trimmer carefully into the material you wish to cut. Tilt the head slowly to direct debris away from you. If cutting up to a barrier such as fence, wall or tree, approach from an angle where any debris ricocheting off the barrier will fly away from you, Move the line head slowly until the grass is cut right up the barrier, but do not jam (overfeed) the line into the barrier. If trimming up to a wire mesh or chain linked fence be careful to feed only up to wire. If you go too far the line will snap off around the wire. Trimming can be done to cut through weed stems one at a time. Place the trimmer line head near the bottom of the weed-never high up which could cause the weed to chatter and catch the line. Rather than cut the weed right through, just use the very end of the line to wear through the stem slowly.

### **WARNING!**

Do not use a steel blade for edging or scalping.

## Scalping And Edging

Both of these are done with the line head tilted at a steep angle Scalping is removing top growth leaving the earth bare. Edging is trimming the grass back where it has spread over a sidewalk or drive way. During both edging and scalping, hold the unit a steep angle and in a position where the debris, and any dislodging dirt and stones, will not come back towards you even if it ricochets off the hard surface. Every operator must find for himself the angles which suits his body size and cutting situation.

### **WARNING!**

Do not trim in any area where there are strands of fencing wire. Wear PPE safety clothing. Do not cut where you cannot see what the cutting device is cutting.



# Maintenance & Care

## Safety

 **1. WARNING** - Before cleaning or doing maintenance work, you need to disconnect the spark plug cable and read the relevant instructions. You need to wear proper clothing and protective gloves whenever your hands are at risk.

 **2. WARNING** - If there are worn or damaged parts, never use the machine. Faulty or worn-out parts must be replaced and not repaired. You must only use original spare parts. The use of non-original and/or incorrectly fitted parts will jeopardize the safety of the machine. This may also cause accidents or personal injuries for which the manufacturer is under no circumstance liable or responsible.

**3.** Any maintenance operations or adjustments not explained in this manual must be carried out by your Dealer or a specialised Service Centre with the necessary knowledge and equipment to ensure that the work is done correctly maintaining the trimmer's original safety level. Any operations performed in unauthorised centres or by unqualified persons will invalidate the Warranty and all obligations and responsibilities of the Manufacturer.

**4.** Disconnect the spark plug cable and check machine for damage after each use.

**5.** To be sure the machine is in safe working condition, keep all nuts, screws and bolts tight. Routine maintenance is essential for safety and for maintaining a high performance level.

**6.** On a regular basis, check that the screws are properly tightened.

**7.** Be very careful during adjustment of the machine to prevent entrapment of the fingers.

**8.** If any warning message stickers or instruction is damaged, replace them.

**9.** Store the machine in a safe place, out of the reach of children.

**10.** Do not store the machine with fuel in the tank in an area where the fuel vapours could reach an open flame, a strong heat source or a spark.

**11.** Engine must be cooled down before storing.

**12.** To reduce fire hazards, keep the engine, silencer, battery compartment and petrol storage area free of grass, leaves, or excessive grease. Do not leave containers full of cut grass inside storage areas.

**13.** To reduce fire hazards, check there is no oil and/or fuel leaks on a regular basis.

**14.** If you need to empty the fuel tank, this should be done outdoors once the engine has cooled down.

## Routine Maintenance

 **IMPORTANT** - Routine and accurate maintenance is essential for maintaining original machine safety and performance levels.

Always stop the engine and unplug the spark plug before doing any repairs or maintenance.

Only use original spare parts: The use of non-original and/or incorrectly fitted parts will jeopardize the safety of the machine, may cause accidents or personal injuries for which the Manufacturer is under no circumstance liable or responsible.

Make sure not to drip petrol onto the plastic parts to prevent damaging them and remove all traces of spilled petrol immediately. The warranty will not cover damage to plastic parts caused by petrol.

# Maintenance & Care

**⚠ CAUTION - DO NOT** use a hose pipe or pressure washer to clean the engine. Water can damage the engine or contaminate the fuel system.

## Air Filter

Accumulated dust in the air filter will reduce engine efficiency. Increase fuel consumption and allow abrasive particles to pass into the engine. Remove the air filter as often as necessary to maintain in a clean condition.

Light surface dust can readily be removed by tapping the filter. Heavy deposits should be washed out in suitable detergent.

Remove filter cover by loosening air filter cover knob.

**⚠ CAUTION -** A dirty air filter will restrict the air flow to the carburetor, which will reduce engine efficiency.

When using the lawnmower in very dusty areas you must clean or replace the air filter more often.

Never operate the machine without the air filter being fitted it can cause damage to the engine which is not covered by warranty.

## Adjusting Carburetor

Do not adjust carburetor unless necessary. If you have trouble with the Carburetor, see your dealer. Improper adjustment may cause engine damage and void warranty.

## Spark Plug

Do not attempt to remove the plug from a hot engine in order to avoid possible damage to the threads

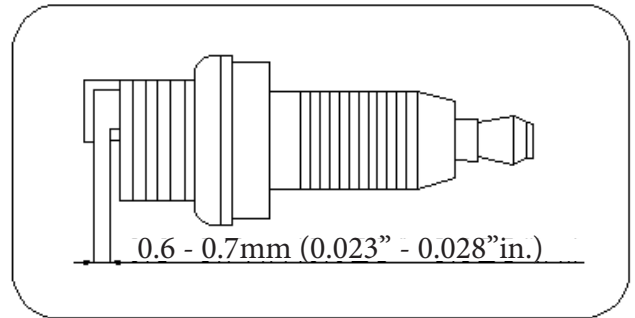

1. Clean or replace the plug if fouled with heavy oily deposits.
2. Replace the plug if the center electrode is worn rounded at the end.
3. Spark gap 0.6-0.7mm (.023\".028\")
4. Tightening torque = 145-155kg.cm (125-135in.lb)

## Fuel Filter

- The fuel tank is fitted with a filter. The filter is situated at the free end of fuel pipe and can be picked out through fuel port with a piece of hooked wire.
- Check the fuel filter periodically. Do not allow dust to enter into fuel tank. A clogged filter will cause difficulty in starting engine or abnormalities in starting engine or abnormalities in engine performance.
- When filter is dirty, replace the filter.
- When the inside of the fuel tank is dirty, it can be cleaned by rinsing the tank out with petrol.

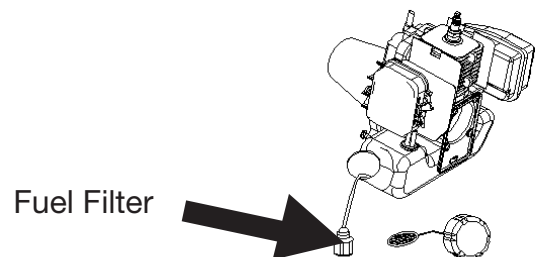

# Maintenance & Care

## Fuel & Oil Mixture

**⚠ CAUTION - ALL FUELS ARE FLAMMABLE**

**NOTE** - All machines are tested and inspected so there may be some residual oil left in the machine so please fill with caution.

- **ALWAYS** fuel and defuel in a well ventilated area outside of buildings.
- **ALWAYS** wear correct, suitable and fit for purpose Personal Protective Equipment (PPE), suggested items are but not limited to safety gloves, overalls and work boots.
- **NEVER** fill the fuel to the very top.
- **DO NOT** add fuel to this unit close to an open fire or sparks.
- **YOU MUST** wipe off spilled fuel before attempting to start engine.
- **DO NOT** attempt to refuel a hot engine.
- When preparing fuel mixture, mix only the amount needed for the job you are to do. Do not use fuel that has been stored longer than two months. Fuel mixture stored longer than this will make starting difficult and give poor performance. If fuel mix has been stored longer than this time. It should be removed and filled with fresh mixture.
- Never remove the fuel tank cap when the engine is running.

The engine uses 2-stroke fuel, a mixture of petrol and 2-stroke lubricant 40:1 or use Aspen2 pre-mix. Do not use old, stale petrol.

Mixture ratio is 40:1 (unleaded petrol: 40 parts, oil: 1 part)

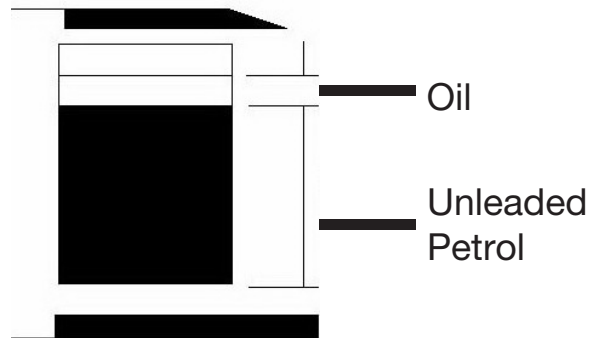

Fuel mixture at the rate other than 40:1 may cause damage to the engine, Ensure mixture ratio is correct.

Use fresh unleaded petrol.

### **IMPORTANT!**

2-stroke fuel may separate. Shake fuel container thoroughly before each use. **DO NOT** mix petrol and oil directly in the engine fuel tank. Failure to follow proper fuel mix instructions may cause damage to the engine.

## Transportation And Handling

1. Whenever the machine is to be handled, lifted, transported or tilted you must:
  - Wear sturdy work gloves
  - Hold the machine at the points that offer a safe grip, taking into account the weight and relative distribution of the same
  - Use an appropriate number of people for the weight of the machine and the characteristics of the vehicle or the place where it must be placed or collected
  - You must make sure that machine movements do not cause petrol leaks, damage or injuries.
2. During transport, make sure to fasten the machine securely with rope or straps.

After the engine has stopped, it is still hot. Never touch the hot parts.

# Maintenance & Care

## Cleaning

 **CAUTION - DO NOT** use a hose pipe or pressure washer to clean the engine. Water can damage the engine or contaminate the fuel system.

- Wipe the deck with a dry cloth.

**NOTE** Engine must be switched off and plug lead disconnected.

- You must remove grass and mud from the machine to prevent it from drying. This will cause problems the next time the machine is used.
- Dry the machine completely to prevent any rust forming.
- Avoid using solvents when cleaning plastic parts. Most plastics are susceptible to damage from various types of commercial solvents and may be damaged by their use.

## Storage

 **CAUTION** - When storing the machine, make sure it has been cleaned as in the previous section. You can use a light oil or silicone spray to coat the equipment.

**NOTE** - If storing the machine for a period of 30 days or more, you must follow proper storage and winterisation guidelines to avoid any possible issues with your machine. Incorrect storage can lead to possible fueling or engine issues that will not be covered by the warranty.

The following steps should be taken to prepare your machine for storage.

1. Drain all the fuel from the fuel tank and then run the machine until it has completely run out of fuel to clear the remaining fuel from the fuel lines and carburetor.

2. With the machine drained of all fluids, follow the cleaning instructions as set out in the previous section.

3. Follow the maintenance section and check, service or replace serviceable items if required.

4. Using a silicone spray grease, lightly grease all moving parts on the machine.

5. Remove the spark plug and pour 1 teaspoon of fresh engine oil down the cylinder bore. Cover the spark plug hole with a lint free clean cloth, ensuring no dirt or debris falls into the cylinder chamber and gently pull the recoil starter handle to coat the cylinder bore with the fresh oil.

6. Refit the spark plug.

7. Once all work above is carried out store the machine in a clean, cool and dry place away from sources of ignition and varying changes in temperature. **DO NOT** store a machine that has not been given time to fully cool down.

## Contact Us



# Troubleshooting

## Failure To Start

Problem		Possible Cause	Possible Solution	
Cylinder compression pressure normal	Spark plug spark normal	Fuel system abnormality	<ol style="list-style-type: none"> <li>1. There is no fuel in tank</li> <li>2. Fuel filter obstruct</li> </ol>	<ol style="list-style-type: none"> <li>1. Add fuel in tank</li> <li>2. Clean fuel filter</li> </ol>
		Fuel system normal	<ol style="list-style-type: none"> <li>1. Fuel is too dirty</li> <li>2. There is water in fuel</li> <li>3. There is too much choke</li> <li>4. Mixture ratio is improper</li> </ol>	<ol style="list-style-type: none"> <li>1. Change fuel</li> <li>2. Change fuel</li> <li>3. Remove spark plug and dry it</li> <li>4. Use 40:1 petrol and oil mixture</li> </ol>
	Fuel system normal	High voltage wire spark normal	<ol style="list-style-type: none"> <li>1. Spark plug fouled with oily deposits</li> <li>2. Spark plug insulation damage</li> <li>3. Spark gap is too large or small</li> </ol>	<ol style="list-style-type: none"> <li>1. Clean the oil deposits</li> <li>2. Replace spark plug</li> <li>3. Adjust spark gap 0.6-0.7mm</li> </ol>
		High voltage spark abnormality	<ol style="list-style-type: none"> <li>1. High voltage wire breach or break off</li> <li>2. Coil looseness</li> </ol>	<ol style="list-style-type: none"> <li>1. Replace or tighten</li> <li>2. Tighten</li> </ol>
Fuel system normal	Ignition system normal	Low compression	<ol style="list-style-type: none"> <li>1. Piston ring worn</li> <li>2. Piston ring is broken</li> <li>3. Piston ring jammed</li> <li>4. Spark plug loose</li> <li>5. Gasket between the cylinder and crank case leaking</li> </ol>	<ol style="list-style-type: none"> <li>1. Replace</li> <li>2. Replace</li> <li>3. Free piston ring</li> <li>4. Tighten</li> <li>5. Fit new gasket</li> </ol>
		Normal compression	<ol style="list-style-type: none"> <li>1. High voltage wire and spark plug contact faulty</li> <li>2. Stop switch failure or short circuit</li> </ol>	<ol style="list-style-type: none"> <li>1. Tighten the spark plug cap</li> <li>2. Repair or replace</li> </ol>

# Troubleshooting

Failures such as difficulty in starting engine, irregularity in functions and abnormality in performance can normally be prevented if careful attention is paid to all operating instructions and maintenance procedures.

Failure to start:

- Dispose of fuel in the tank.
- Insure that fuel is fresh and clean.
- Check fuel filter to make sure it is clean. (Replace filter if necessary).
- Make sure air filter elements are clean.
- Install new, properly gapped spark plug.
- When there is serious trouble with the unit, do not try to repair it yourself but have your distributor or dealer do it for you.

## Low Output

Problem	Possible Cause	Possible Solution
Flame from exhaust when at high speed	Fuel filter obstruct	Clean fuel filter, clean fuel tank.
Blue smoke	Too much fuel or oil	Adjust carburetor or oil mixture
Backfire through carburetor	Muffler fouled with oily deposits	Clean the oily deposits
Low compression	Worn piston, rings, cylinder	Replace piston, piston rings and cylinder
Engine gasket leak	Faulty gaskets	Fit new gaskets
Crankshaft oil leak	Faulty or worn seal	Replace seal
Engine overheats	Check for air-cooling obstruction	Avoid long periods of over heavy use
Exhaust muffler oiled up	Check fuel/oil mixture	Clean the oily deposits



# Troubleshooting

## Engine Running Unstable

Problem	Possible Cause	Possible Solution
Metal knocking sound	Piston, piston rings, cylinder worn	Replace piston, piston rings, cylinder
	Crank bearings worn.	Replace bearings
Metal knocking sound	Engine overheats	Replace fuel with correct mixture of unleaded petrol and semi-synthetic 2-stroke oil at 40:1 ratio.
Engine cuts out	There is water in fuel	Replace fuel
	Spark gap is wrong	Adjust spark gap 0.6-0.7mm
	Coil gap is wrong	Adjust coil gap 0.3-0.4mm

## Engine Suddenly Stopped

Possible Cause	Possible Solution
Fuel tank is empty	Add fuel
Spark plug fouled with oily deposits	Clean the oily deposits
Spark plug cap loose	Reconnect spark plug cap

## Spare Parts

Part	Part Number
Recoil Start	HYTR2600XRECOIL
Guard	HYTR2600XGUARD
Spark Plug	HYTR2600XSPARKPLUG



# Specifications

## Main Unit Specifications

Remote type	Direct Drive; flexible curved shaft	
Maximum speed of trimmer shaft /engine speed (rpm)	9000/9000	
Idle speed (rpm)	3000	
Vibration values at each handle (m/s <sup>2</sup> )	15	
Sound pressure values [dB(A)]	102	
Sound power values [dB(A)]	95	
Guaranteed Sound power values [dB(A)]	106	
Line Max. Cutting Path	15"/38 cm	
Nylon head rotation direction	Clockwise (looking from above)	
Type of aluminium pole	Single shaft	Split shaft
Net weight (kg)	4.8	5

## Engine Specifications

Engine Model	IC26-2J
Type	Air-cooled, 2-stroke petrol engine
Displacement	25.4cc
Maximum output	0.65kW / 7500rpm
Carburetor	Diaphragm-type
Ignition	Contactless electronic ignition
Start method	Recoil
Fuel	Unleaded petrol and Semi-synthetic 2-stroke oil (ratio 40:1) or Aspen 2 premix.
Fuel tank capacity (ml)	500

Contact Us



[www.hyundaipowerproducts.co.uk](http://www.hyundaipowerproducts.co.uk)



01646 687 880



[aftersales@hyundaipowerproducts.co.uk](mailto:aftersales@hyundaipowerproducts.co.uk)

# Disposal

## Environmental Protection

1. Environmental protection should be a priority of considerable importance when using the machine, for the benefit of both social coexistence and the environment in which we live. Try not to cause any disturbance to the surrounding area.
2. You must comply with local regulations and provisions for the disposal of packaging, oils, petrol, filters, damaged parts or any elements which have a strong impact on the environment. This waste must not be disposed of as normal waste. It needs to be separated and taken to specified waste disposal centres where the material will be recycled.
3. You must comply with local regulations for the disposal of waste materials after mowing.
4. When disposing, do not pollute the environment with the machine, but hand it over to a disposal centre, in accordance with the local laws in force.

## Recycling And Disposal



We do not offer a takeback scheme for the recovery of Waste Electrical Electronic Equipment (WEEE) & Batteries. Instead the responsibility to dispose of WEEE and or Batteries is passed onto you by us.

So when it becomes necessary to dispose of your machine you must take it to your local Civic Amenity Site. For further information please contact your local Authority for disposal advice.

You **MUST** make sure that all unused oil and fuel is disposed of correctly either beforehand

or at your local Civic Amenity Site.

Under NO circumstances must any fuel or oil be put down any drains.

Certain products contain WEEE waste which should not be disposed of in your domestic waste.

You **MUST** recycle WEEE in accordance with your local authority or recycling centre.

Certain products contain batteries which should not be disposed of in your domestic waste.

You **MUST** recycle batteries in accordance with your local authority or recycling centre.

Unwanted packaging and materials should be stored and taken to a recycling centre so it can be disposed of in a manner which is compatible with the environment.

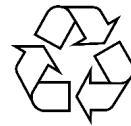

This symbol means you should 'Reduce - Reuse - Recycle'

We are a Member of the VALPAK National Compliance Scheme and our registration number is **RM08660**

For further information about disposal please contact your Local Authority.

You can also get more advice and guidance about recycling at the following website <http://www.recycle-more.co.uk>

Should you pass this product on to another user either sold or loaned, you **MUST** pass on this user manual. This will make sure that all other users can use and maintain this machine safely.

# Our Product Range

## Generators

Leisure Inverter, Petrol, Diesel And Built-In Motorhome Generators

## Pressure Washers

Petrol, Diesel And Electric Pressure Washers

## Water Pumps

Submersible, Clean And Dirty Water And Professional Chemical Water Pumps

## Lawnmowers

Petrol, Cordless, Electric, Roller, Self Propelled And Electric Start Lawnmowers

## Grass Trimmers And Brushcutters

Petrol, Cordless And Wheeled Grass Trimmers And Brushcutters

## Chainsaws

Petrol, Cordless And Electric Chainsaws

## Hedge Trimmers

Petrol And Cordless Hedge Trimmers

## Leaf Blowers

Petrol, Electric, Cordless, Backpack And 3 -in-1 Leaf Blowers

## Log Splitters

Horizontal, Vertical, Petrol And Electric Log Splitters

## Wood Chippers

Petrol And Electric Start Wood Chippers

## Tillers

Petrol Garden Tiller And Cultivator

## Earth Augers And Trenchers

Petrol Earth Augers And Heavy Duty Trenchers

## Compactor Plates

Petrol Compactor Plates

## Cement Mixers

Portable Electric Cement Mixers

## Mini Dumpers

4-Wheel Drive Mini Dumper / Power Barrow

## Yard Sweeper

Self Propelled Yard Sweeper Power Brush

## Scarifiers

Petrol Lawn Scarifier And Aerator

## Stump Grinders

Petrol 4-Stroke Stump Grinders

## Welders And Plasma Cutters

MIG, TIG, MMA, ARC Welders And Plasma Cutters

## Power Tools And Tool Chests

Electric And Cordless Power Tools And Caster Mounted Tool Chests

## Vacuum Cleaners

Wet And Dry Vacuum Cleaners

## Engines

Petrol And Electric Start Engines

## Battery Chargers / Starters

6V, 12V, 24V Battery Chargers, Jump Starters And Hydraulic Floor Jack

## Air Compressors

Home, Domestic, DIY And Professional Use Air Compressors

## Lighting Towers

Mobile Lighting Towers With Diesel Generators

## And More

We Are Constantly Expanding Our Range With New Products

If you would like more information on any of these products, please contact our sales team on 01646 687880 or visit our website [www.hyundaipowerproducts.co.uk](http://www.hyundaipowerproducts.co.uk)

## Contact Us



[www.hyundaipowerproducts.co.uk](http://www.hyundaipowerproducts.co.uk)



01646 687 880



[aftersales@hyundaipowerproducts.co.uk](mailto:aftersales@hyundaipowerproducts.co.uk)

# Useful Information

## Check Out Our YouTube Channel

---

Our videos on YouTube include:

- Unboxing
- Assembly of your machine
- How to service your machine
- Products in use
- 'How To' videos
- Product features

Go to [www.hyundaisupport.co.uk](http://www.hyundaisupport.co.uk) or search 'Hyundai Power Products' in YouTube.

## Warranty

---

Register your 3 year warranty within 30 days of purchase at:  
[www.hyundaipowerequipment.co.uk/warranty](http://www.hyundaipowerequipment.co.uk/warranty)

Full warranty terms and conditions can be found on the HYUNDAI POWER PRODUCTS website:  
[www.hyundaipowerproducts.co.uk](http://www.hyundaipowerproducts.co.uk)

## Manual Updates

---

Our manuals are constantly being reviewed and updated. Should you find an error, omission or something unclear, please contact us for assistance.

We reserve the right to make any modifications without prior notice whenever necessary.

Our latest manuals are also placed online. All our manuals can be downloaded at:  
[www.hyundaipowerproducts.co.uk](http://www.hyundaipowerproducts.co.uk)

## Returning Your Product

---

If you are returning your product, please contact the dealer for their returns policy.

## Leaving A Review

---

We work very hard to give all of our customers the best possible service.

If you have any problems, before leaving negative feedback, please contact us to give us a chance to resolve the issue.

We would be delighted if you left us positive feedback!

To leave a review, please go to:  
[uk.trustpilot.com/review/hyundaipowerequipment.co.uk](http://uk.trustpilot.com/review/hyundaipowerequipment.co.uk)

## Ordering Spare Parts

---

Only use original spare parts: The use of non-original and/or incorrectly fitted parts will jeopardize the safety of the machine, may cause accidents or personal injuries for which the Manufacturer is under no circumstance liable or responsible.

See page 24 for part numbers.



# Need Help? Talk To Our Experts

## Contact Us

---

**Our friendly aftersales team will be more than happy to help you.**

### Phone

Call our team on 01646 687880, open Monday-Friday 8.30am-5pm.

### Email

[aftersales@hyundaipowerproducts.co.uk](mailto:aftersales@hyundaipowerproducts.co.uk)

### Online Live Chat

Go to [www.hyundaipowerproducts.co.uk](http://www.hyundaipowerproducts.co.uk)

Live chat is open Monday-Friday from 8.30am-5pm.

### Post

Genpower Limited, Isaac Way, Pembroke Dock, Pembrokeshire, SA72 4RW, UK.

# Declaration Of Conformity

## EC Declaration of Conformity

We hereby declare that the machine detailed in this declaration complies to all the relevant provisions of the following EC directives.

- 2006/42/EC The Machinery Directive
- 2014/30/EU Annex II Electromagnetic Compatibility Directive
- 2016/1628/EC The Emission of Gaseous and Particulate Pollutants from internal Combustion engines
- 2000/14/EC Noise Emissions in the Environment by Equipment for use Outdoors.

And is in conformity with the applicable requirements of the following documents:

- EN ISO 11806-1:2011
- EN ISO 10517:2019

Declaration for 2000/14/EC Noise Emissions in the Environment by Equipment for use Outdoors.  
Notified Body for EC Directive 2000/14/EC TÜV Rheinland (Shanghai) Co., Ltd.

Model	Type	Engine Size	Measured Sound Power	Guaranteed Sound Power	Engine output
HYTR2600X	Grass Trimmer	25.4cc	95dB(A)	106dB(A)	0.65kW

### Product Details

Brand: Hyundai

Model: HYTR2600X

Description: Petrol grass trimmer.

### Name and address of technical documentation holder and EU distributor:

Genpower Ltd, Isaac Way, Pembroke Dock, Pembrokeshire, SA72 4RW, UK.

Signed by:



Roland Llewellyn, Managing Director

Date: 23/12/2019

## Contact Us



[www.hyundaipowerproducts.co.uk](http://www.hyundaipowerproducts.co.uk)



01646 687 880



[aftersales@hyundaipowerproducts.co.uk](mailto:aftersales@hyundaipowerproducts.co.uk)

# HYUNDAI

POWER PRODUCTS

Importer:  
GENPOWER LTD  
Isaac Way, London Road,  
Pembroke Dock, UNITED KINGDOM, SA72 4RW  
T: +44 (0) 1646 687 880 F: +44 (0) 1646 686 198  
E: [info@hyundaipowerproducts.co.uk](mailto:info@hyundaipowerproducts.co.uk)  
[www.hyundaipowerproducts.co.uk](http://www.hyundaipowerproducts.co.uk)

Imported/Distributed by Genpower Ltd for The United Kingdom & Ireland

Licensed by Hyundai Corporation, Korea