

HYUNDAI
POWER PRODUCTS

HYUNDAI
POWER PRODUCTS

PETROL INVERTER GENERATOR HY3200SEi

User Manual

Importer:

GENPOWER LTD
Isaac Way, London Road
Pembroke Dock, UNITED KINGDOM, SA72 4RW
T: +44 (0) 1646 687 880 F: +44 (0) 1646 686 198
E: info@hyundaipowerproducts.co.uk
www.hyundaipowerproducts.co.uk

Imported/Distributed by GENPOWER LTD for The United Kingdom & Ireland

Licensed by Hyundai Corporation, Korea



CONTENTS

1.0	Safety Information	03
2.0	Safety Label Location	04
3.0	Component Identification	05
1	Control Panel	06
2	ECON Switch	06
3	Reset/Hours run Meter	07
4.0	Pre-operation Checks	08
1	Oil Level Check	08
2	Fuel Level Check	09
3	Air Filter Check	10
5.0	Starting the Engine	11
6.0	Generator Use	13
1	DC Applications	14
2	AC Applications	16
3	Output & Overload Indicator	16
4	Oil Alert System	17
7.0	Stopping the Engine	18
8.0	Maintenance	19
1	Oil Change	19
2	Air Cleaner Service	20
3	Spark Plug Service	22
4	Spark Arrester Maintenance	23
9.0	Transporting/Storage	25
10.0	Troubleshooting	27
11.0	Technical Specifications	28
12.0	Wiring Diagrams	29
13.0	Appendix	30
1	EC Declarations of Conformity	30
2	Environmental Corrections	31
3	Noise & Access	32
14.0	Consumer Information	32



1.0 Safety Information.

To protect yourself and your property, please carefully read the following instructions.

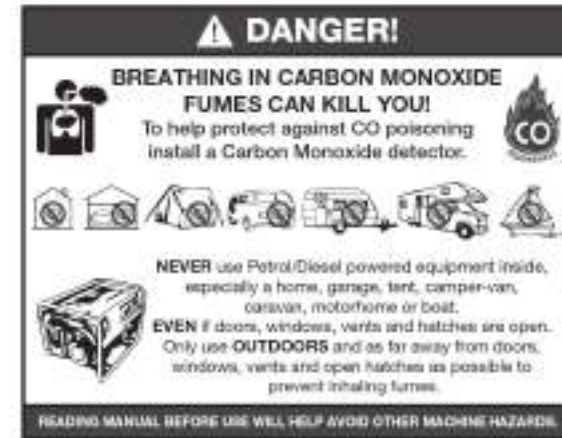

⚠ WARNING

- Read and understand the user manual before using the generator.
- DO NOT use in an enclosed area or a moving vehicle. The engine exhaust gas contains poisonous carbon monoxide. Use the generator in a well ventilated area.
- DO NOT touch the hot exhaust. When the generator is running, or before cooling.
- Petrol is explosive and flammable. When refuelling, the generator needs to be stopped, and fuel kept away from all ignition sources i.e. heaters, lamps, sparks from grinding or welding.
- DO NOT connect to the building's electrical system or another generator, in order to avoid electric shocks and fires.
- The generator must be kept one metre away from all other equipment and flammable materials.
- Place the generator on a the level surface, in order to avoid overturning or spilling fuel.
- Children and pets should be kept away from the generator at all times especially when in operation.
- DO NOT operate with wet hands.
- DO NOT let the generator to come into contact with rain, moisture or snow.
- All major repair work should be carried out by a professionally trained person.
- DO NOT use the generator for underground work.
- DO NOT use the generator in potentially explosive atmospheres.
- Always use personal protective equipment when you operate or maintain the generator, e.g. gloves, mask, earplugs.

3.1 Control Panel.

- | | | | |
|--------------------|--------------------|------------------|---------------------|
| 1. Hours run meter | 2. DC terminal | 3. DC protector | 4. Indicator lights |
| 5. ECON Switch | 6. Fuel switch | 7. Engine switch | 8. 230V 13A socket |
| 9. 230V 13A socket | 10. Earth terminal | | |

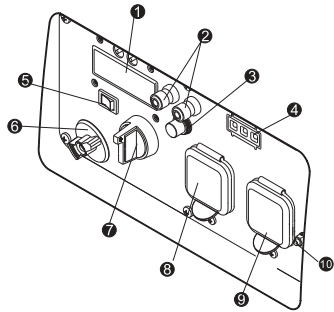

3.2 ECON Switch (Economy Control Switch)

"ON" (↔)

When the economy control switch is turned to "ON" (↔) the engine keeps running at idle state automatically when the electrical appliance is disconnected, and will return to the proper speed when the electrical load requires it.

The "ON" (↔) function is recommended to minimise fuel consumption, reduce noise and prolong engine life.

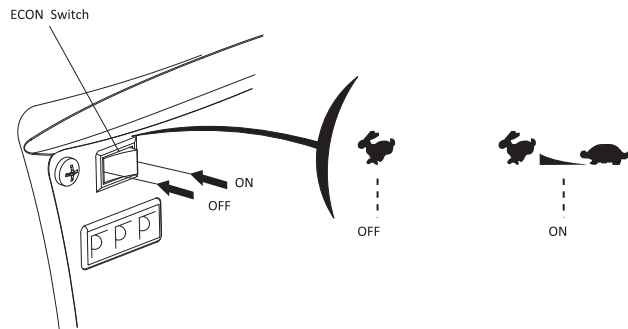

NOTE

When a high load electrical appliance is connected and in order to reduce voltage change, turn the economy control switch to the "OFF" (↔) position. This will allow the engine speed to increase before the load is applied

In DC operation, turn the economy control switch to the "OFF" (↔) position.

Connect both AC load and DC load, turn the economy control switch to the "OFF" (↔) position.

When the economy control switch turns to the "OFF" (↔) the engine runs at high speed.

3.3 Reset/Hours run meter

When the generator goes into overload protection mode, the overload indicator light (RED) will come on, by pressing the "RESET" button the output of the generator can be recovered. It will be unnecessary to restart engine.

Press and hold the "RESET" button for one second, until the overload indicator light (RED) goes off, and the output indicator light (GREEN) comes on.

Under non-overload condition the "RESET" button does not have any function.

When the "DISP" button is pressed the backlight will come on. Successive presses of the "DISP" button will display in turn at each press the Voltage - Frequency - Engine Speed & Cumulative Run Time.

NOTE

If the "DISP" button is not pressed for more than 10 seconds the backlight will turn off.

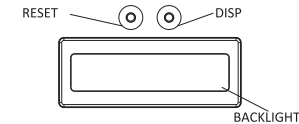

NOTE

When in protection condition, the output indicator light (GREEN) is off and the overload indicator light (RED) is on.

When the generator is started the "RESET" function is available to recover from an overload condition five times, after which time you will have to restart the engine.

4.0 Pre-Operation Checks.

4.1 Oil Level Check.

WARNING

Make sure that the generator has been stopped and is on a level surface. **DO NOT** tilt the generator when adding engine oil this could result in overfilling and engine damage. Remove the oil filler cap, and clean it with a clean cloth, reinsert the oil filler cap (do not screw it in) remove and check the oil level on the dipstick. If the level is low, fill to the upper limit of the oil filler neck with the recommended oil.

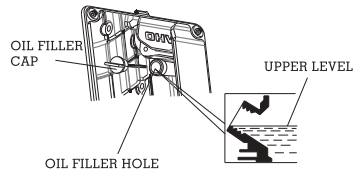

NOTE

DO NOT use non-detergent or 2 stroke oil this could shorten the engines working life. **DO NOT** mix different types of engine oil in this engine. Use a 4 stroke engine oil, certified to meet or exceed API standards: SG, SF or SAE rating. Make sure that you carefully use and store the engine oil. Avoid getting dirt or dust into the engine oil.

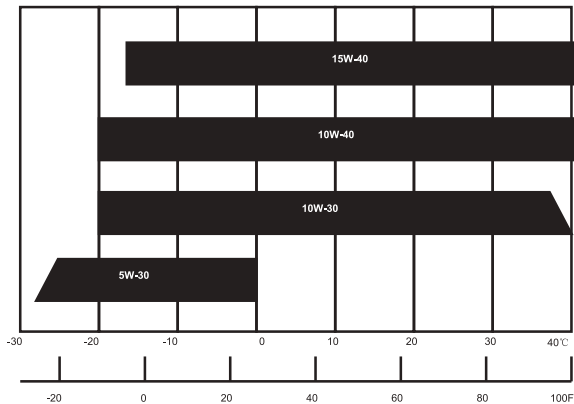

NOTE

If the engine oil falls below the safety margin the low oil alert system will automatically shut off the engine. The oil alert indicator light (RED) will come on. To avoid this inconvenience it is advisable to check the oil regularly

4.2 Fuel Level Check.

Unleaded petrol is the recommended fuel.

Never use stale or contaminated petrol or an oil/petrol mixture. Avoid getting dirt or water into the fuel tank. Do not use a mixture petrol containing ethanol or methanol. This will seriously damage the engine.

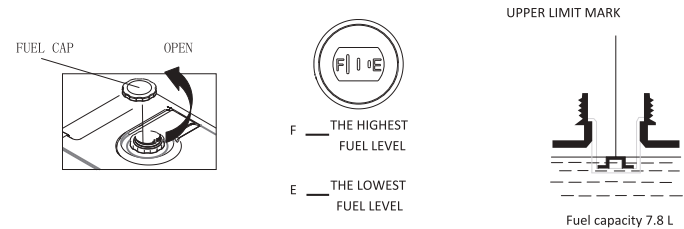

WARNING

Petrol is extremely explosive and flammable. **DO NOT** smoke or allow naked flames or sources of ignition in or around the fuelling area or in fuel storage areas. **DO NOT** overfill the fuel tank (**DO NOT** fuel above the RED upper limit mark). After refuelling make sure that the fuel cap is closed and secure properly. Avoid spilling fuel by using correct refuelling methods. **ALWAYS** clean up spilt fuel immediately after it occurs. Avoid breathing in petrol vapours and direct contact with the skin. **KEEP** all fuels and oils away from and out of reach from children.

4.3 Air Filter Check.

Check the air cleaner element to make sure that it is clean and in good condition.

- a) Undo and remove the maintenance cover screws, and remove the cover.
- b) Loosen the air cleaner cover screws.
- c) Remove the air cleaner cover.
- d) Check the element, clean and replace as necessary.

NOTE DO NOT run the engine without the air filter it can cause engine damage

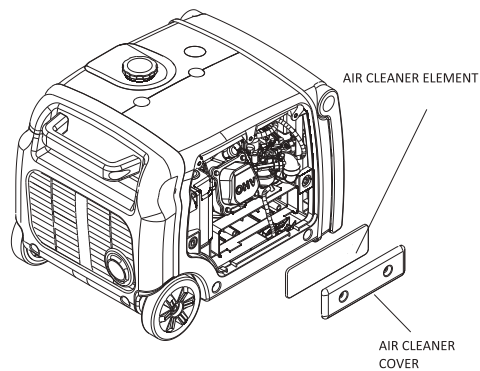
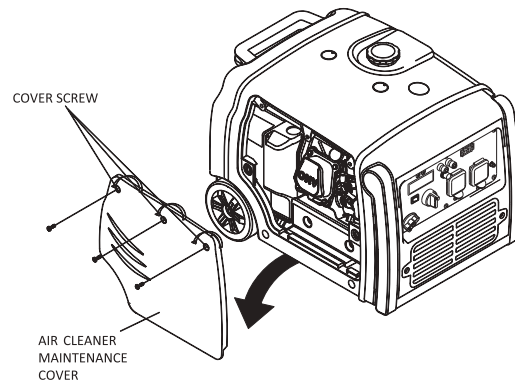

5.0 Starting the Engine.

This generator can be started by three methods, 1) recoil starter, 2) local electrical starting and 3) wireless remote electrical starting.

NOTE

Before starting the engine ALWAYS disconnect the load from the AC Socket.

When fuelling for the first time, or refuelling after long time storage, the engine switch should be turned on wait for 20 seconds. You will then need to pull the recoil starter 10 to 20 times to draw fuel into the carburettor.

5.1 Turn the fuel switch to the ON position.

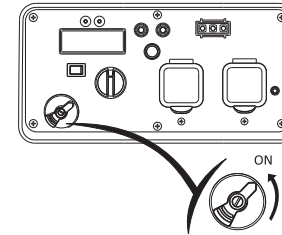

5.2 Turn the engine switch to the RUN/REMOTE position.

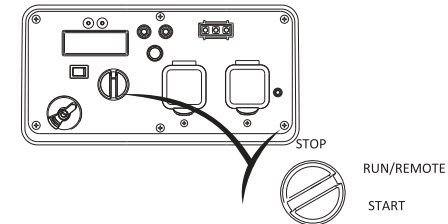

NOTE When the engine switch turn to “RUN/REMOTE” position, the engine will enter the stand-by starting mode. Start the engine within 15min, otherwise, this mode will be ineffective. If the generator re-enters the stand-by starting mode again, the engine switch should be return to “STOP”, and then turn to “RUN/REMOTE”.

5.3 Choose one of the starting modes.

CAUTION If the battery is flat the generator cannot be started by any starting mode.

a. Manual starting

Pull the starter grip slowly until it is engaged, then pull it quickly.

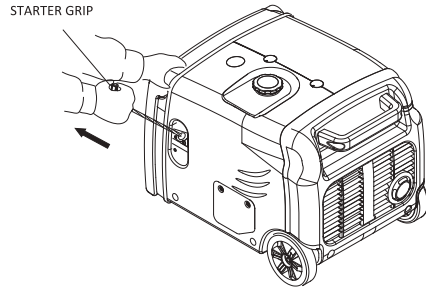

NOTE Return the starter grip slowly by hand. DO NOT let the starter grip spring back.

b. Local electric start.

Turn the engine switch to “START” position, and then let the engine switch return to “RUN/REMOTE” position.

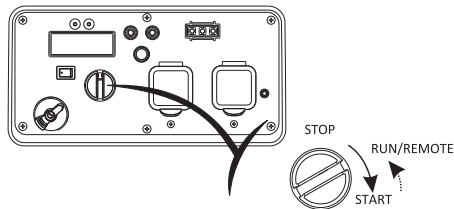

NOTE You should NOT leave in START position for longer than 2 seconds.

c. Wireless remote electrical starting.

Press “ON ” (1) button (1) of the controller once.



NOTE

The remote controller will operate with no obstacles at a distance of 8 metres, and less than 3 metres with obstacles.

In normal use the remote controllers battery will last for approx 2 years.

NOTE

If the generator stops and does not restart, you must first check the oil level.

If the oil alert indicator light (red) is on during when the generator is running, you must add oil.

Carburettor Modification for High Altitude Operation.

At high altitude, the standard carburetor air-fuel mixture will be too rich. Performance will decrease, and fuel consumption will increase. A very rich mixture will also foul the spark plug and cause difficult starting. If the generator operates at high altitude, change the main-nozzle or adjust the idling screw of carburetor.

If the generator always operates at altitude above 1,000 meters, contact your dealer to modify the carburetor.

Generator output power should be modified according to the altitude and ambient temperature. The correction factor refers to 13-2.

WARNING

If the carburetor has been modified for high altitude operation, the air-fuel mixture will be too lean for low altitude use. Operation at low altitude may cause the engine to overheat and result in serious engine damage. The carburetor needs to be returned to its original specification.

6.0 Generator Use.

WARNING

Make sure to ground/earth the generator when the connected appliance is grounded/earthed.

DO NOT connect to the buildings electrical system. Back feeding it is both illegal and highly dangerous.

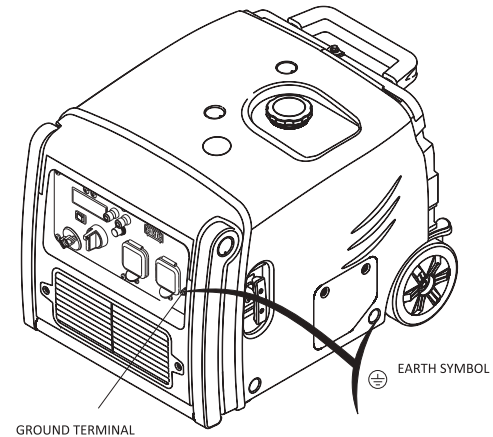

⚠ WARNING

For continuous operation, do not exceed the rated output power of the generator.

DO NOT make parallel connection with mains electrical installations or other generators.

DO NOT connect an extension to the exhaust pipe.

When an extension cable is required, make sure that you use a tough rubber sheathed flexible cable (according to IEC245 or equivalent standards). The length of the extension cable:

60m for cable of 1.5 mm²

100m for cable of 2.5 mm²

Keep away from other electric cables or wires.

NOTE

The AC socket outlet can be used while the DC power is in use. If using both at same time, be

sure not to exceed the total power for AC and DC. (**HY3200SEi** AC - 2.8kVA, DC - 5A)

Most motor appliances require up to 3 times more than their rated wattage when starting.

6.1 DC Application.

The DC receptacle, 15-30V under no-load condition, may be used for charging a 12V battery only.

NOTE

In DC operation, turn the ECON Switch to the "OFF" position (👉)

6.1.1 Disconnect the vehicle battery ground cable from the negative(-) battery terminals.

6.1.2 Connect the DC receptacle to the battery terminals with the charging cable.

6.1.3 the ECON switch to "OFF" (👉) position and then start engine.

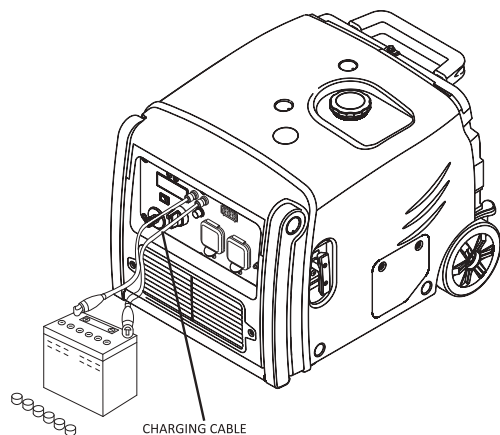

CAUTION

Connect red lead to positive (+) battery terminal and black lead to negative (-) battery terminal.

⚠ WARNING

To avoid producing the sparks at the terminals of battery, connect the charging cables firstly to the battery terminals, and then to the generator. When disconnecting the cables do so first at the generator.

Before connecting the charging cables to a battery that is installed in a vehicle, the grounded/chassis cable of the battery should be disconnected first. This sequence will prevent sparks or a short-circuit, if the cable accidentally contacts the vehicle's frame or body.

NOTE

Do not start the car's engine when the generator is still connected to the battery, otherwise the generator will be damaged.

Connect the positive battery terminal to the positive charging cable. Do not reverse the charging cable, otherwise generator or battery will be damaged seriously.

⚠ WARNING

When charging the battery releases highly explosive oxygen/hydrogen gases. Keep the battery away from sparks/fire and other sources of ignition. Always charge the battery in a well ventilated area.

Battery electrolyte contains sulphuric acid which will cause severe burns if it comes into contact with the skin and eyes. Therefore it is necessary to wear the protective clothing and mask.

If battery electrolyte gets into eyes or onto skin, flush thoroughly with warm water for 15 minutes at least, and call a doctor immediately.

If you accidentally swallow any battery electrolyte, call for medical/first aid assistance immediately. If no medical/first aid assistance is available call or get someone else to dial 999.

Keep batteries and electrolyte OUT OF REACH OF CHILDREN.

NOTE

The DC receptacle can be used while the AC power is in use.

When DC circuit overload will trip the DC circuit protector, remove load firstly, and then reset the protector after a few minutes.

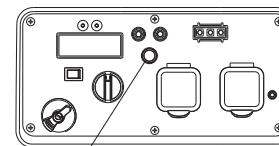

DC protector

6.2 AC Applications.

6.2.1 Start engine and make sure the output indicator light (GREEN) is on.

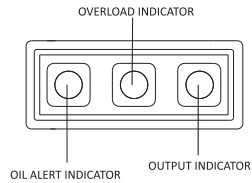

6.2.2 Confirm all electrical appliances are switched off, then connect the appliance plugs to the generator AC socket.

NOTE

To obtain the best working and longest working life of the generator, you should make sure that you run the generator for 20 hours at 50% rated load.

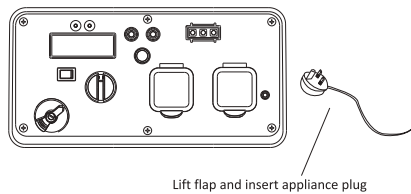

NOTE

Confirm all electrical appliances are in good working condition before connecting them to the generator. If an electrical appliance becomes abnormal, sluggish, or stops suddenly, shut off the generator engine immediately, and disconnect the appliance.

6.3 Output and Overload Indicator

In normal operating conditions, the output indicator light (GREEN) will remain on. If the generator is overloaded, or the connected appliance is short-circuited, the output indicator light (GREEN) will go out, and overload indicator light (RED) will come on. The 230V output will be cut and the engine will remain running.

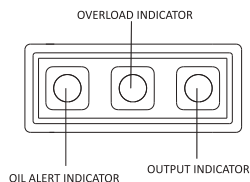

If the overload indicator light (RED) is on, disconnect the electrical appliances first, then press and hold the reset button for 1 second. If the overload indicator light (RED) is off and the output indicator light (GREEN) is on, reconnect the electrical appliances. Otherwise stop the engine and check the generator.

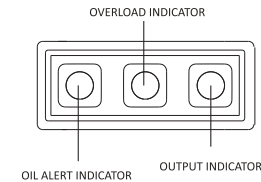

NOTE

When you start the engine, it is normal for both the overload indicator light (RED) and output indicator light (GREEN) to be ON simultaneously. The overload indicator light will go OFF after 5 seconds, otherwise contact your dealer.

6.4 Oil Alert System.

The oil alert system is designed to prevent engine damage caused by an insufficient amount of oil in the crankcase. Before the oil level in the crankcase falls below a safe limit, the oil alert system will automatically shut down the engine (the engine switch remains in the "ON" position). If the oil alert system shuts down the engine, the oil alert indicator light (red) will be on. Check the engine oil level.

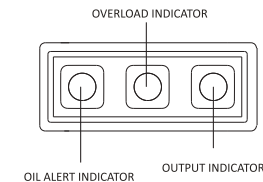

7.0 Stopping the Engine.

To stop the engine in an emergency, turn the engine switch to the "OFF" position.

7.1 Switch off the connected electrical appliances and remove their plugs from the AC sockets.

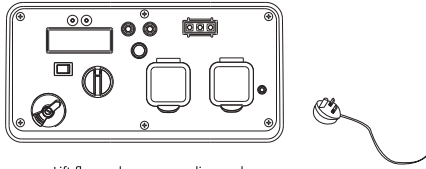

Lift flap and remove appliance plug

7.2 Turn the engine switch to the "STOP" position or press the " OFF " button (2) on the remote controller, then turn the fuel switch to the 'OFF' position

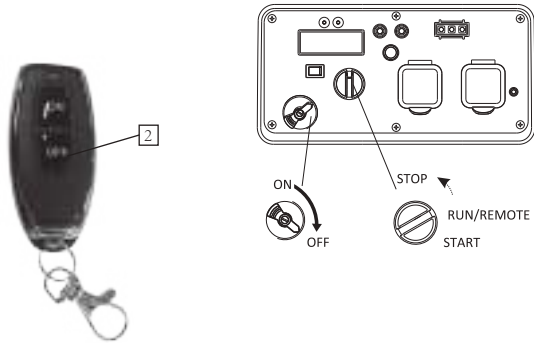

8.0 Maintenance.

The purpose of the maintenance schedule is to keep the generator in the best operating condition.

⚠ WARNING

Stop the engine before performing any maintenance. If the engine must run, be sure the area is well ventilated. The exhaust contains poisonous carbon monoxide gas.

Only use genuine Hyundai spares to replace worn components.

Maintenance Schedule.

Regular service period (3)		Every use	1 st month or 10 hrs	Every 3 mths or 50 hrs	Every 6 mths or 100 hrs	Every 2 years or 300 hrs
ITEM						
Engine oil	Check level	⊖				
	Change		⊖		⊖	
Air filter	Check	⊖				
	Clean			⊖ (1)		
Spark plug	Check/adjust				⊖	
	Replace					⊖
Spark arrester	Clean				⊖	
Valve clearance	Check/adjust					⊖ (2)
Combustion chamber	Clean	After every 300 hrs (2)				
Fuel tank & filter	Clean	Every year (2)				
Fuel line	Check	Every 2 years – replace as required (2)				

NOTE

(1) Service more frequently when used in dusty areas.

(2) These items should be serviced by your servicing dealer, unless you have the proper tools and are mechanically proficient. Refer to dealer for service procedures.

(3) For commercial use and/or long hours of operation you must maintain proper maintenance intervals.

8.1 Oil Change.

Drain the oil whilst the engine is still warm.

8.1.1 Loosen the maintenance cover screw, and remove the cover.

8.1.2 Remove the oil dipstick and the rubber seal.

- 8.1.3 Place oil collection pan under oil drain plug. Drain dirty oil into a container thoroughly.
- 8.1.4 Refill the recommended oil and check the oil level.
- 8.1.5 Reinstall the oil filler cap.
- 8.1.6 Reinstall the maintenance cover and tighten the cover screw.

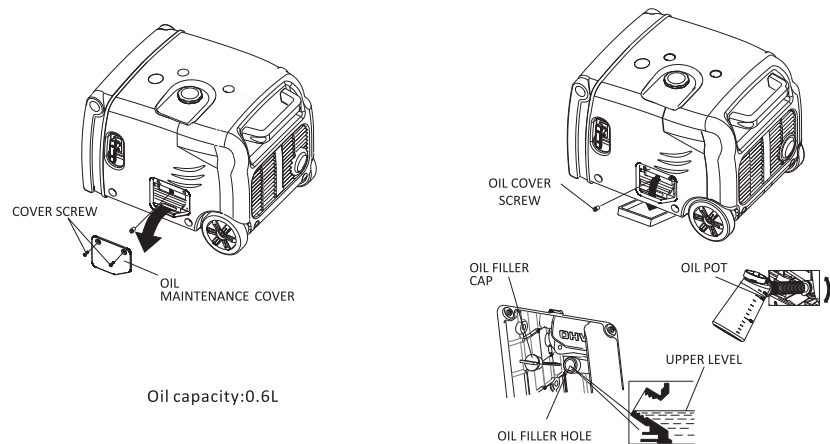

After oil change, wash your hands with soap.

NOTE

To conform with environmental requirements, the used oil should be put into a sealed container and then be transported to an amenity recycling centre. Do not throw it into the rubbish or pour it on the ground.

8.2 Air Cleaner - Service.

A dirty air cleaner will restrict air flow into the carburetor. Clean and maintain the air cleaner regularly, especially in the extremely dusty areas.

WARNING

Do not use petrol or low ignition paint solvents for cleaning. They are flammable and explosive under certain conditions.

NOTE

Never run the generator without air cleaner or rapid engine wear may occur.

- 8.2.1 Loosen the screws of the air cleaner maintenance cover, and remove the cover.

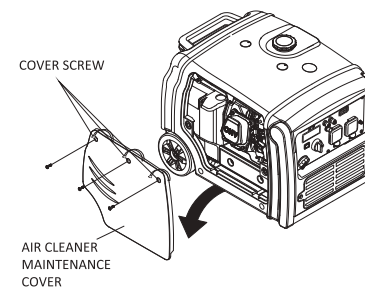

- 8.2.2 Loosen the air cleaner cover and remove.

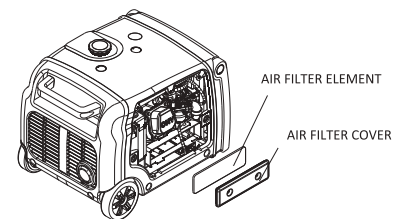

- 8.2.3 Take out the air cleaner element, and clean it with a non-flammable or high flash point solvent, then dry it.
- 8.2.4 Soak the air cleaner element air filter in oil, and squeeze out the redundant oil.

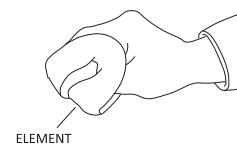

8.2.5 Refit the air cleaner element and cover.

8.2.6 Refit the maintenance cover, and tighten the screws.

8.3 Spark Plug Service.

Recommended spark plug: F7TC

Check the spark plug gap and clean the carbon deposition at the bottom of the spark plug.

8.3.1 Remove the spark plug CAP.

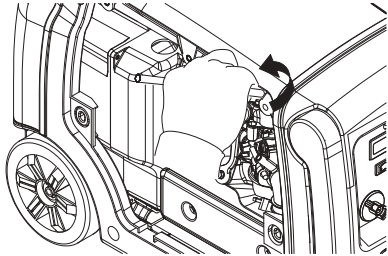

8.3.2 Remove the spark plug using spark plug spanner.

8.3.3 Clean the carbon deposition at the bottom of the spark plug.

8.3.5 Visually inspect the spark plug. Change for a new one if its insulator is cracked or chipped. Clean it with a wire brush if the spark plug is going to be re-used.

0.60-0.70mm
(0.024-0.028in)

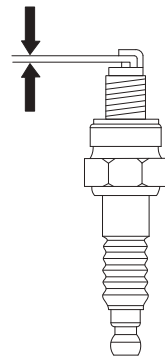

8.3.6 Measure the spark plug gap with a feeler gauge. The normal value: 0.6-0.7mm (0.024-0.028in). Adjust the gap by bending the electrode carefully.

8.3.7 Refit the spark plug carefully, by hand, to avoid cross-threading. A new spark plug should be tightened 1/2 turn with a spanner. A used spark plug should be tightened 1/8 to 1/4 turn with spanner.

8.3.8 Reinstall the spark plug cap.

8.3.9 Reinstall the spark plug maintenance cover.

NOTE

The spark plug must be securely tightened. If refitted incorrectly (i.e. cross threaded) this will damage the cylinder head.

Never use a spark plug with an improper heat range.

8.4 Spark Arrester Maintenance.

⚠ WARNING

The spark arrester must be maintained every 100 hour service.

8.4.1 Remove the screws, and remove the muffler guard.

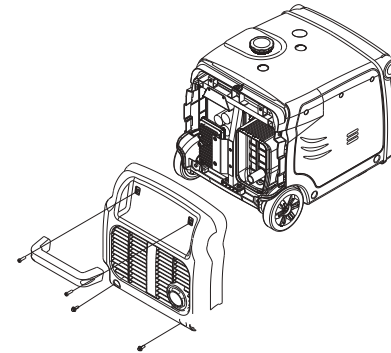

8.4.2 Once the engine cools down remove the spark arrester from the exhaust.

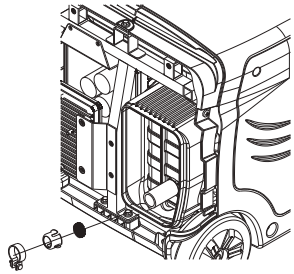

8.4.3 Remove carbon deposits of the spark arrester using a wire brush. If the spark arrester is worn, replace it.



8.4.4 Refit the spark arrester and exhaust guard.

8.5 Replace battery and fuse.

8.5.1 Loosen the battery maintenance cover screws, and remove the cover.

8.5.2 Unhook the battery belt. Remove the black cable from the battery negative “-” terminal and then remove the red cable from the positive “+” terminal.

8.5.3 Remove the battery from the battery tray and replace with a new one.

8.5.4 Re-connect the cables in reverse order, red then black.

8.5.5 Hook the belt around battery and refit the cover.

Battery Specification

Voltage - 12V
Capacity - 7Ah
Dimension - 138 x 66 x 88 mm

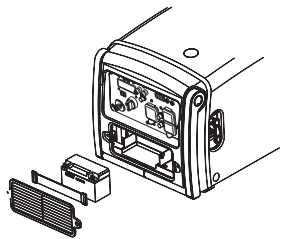

9.0 Transporting/Storage.

Avoid fuel spillages during transportation or temporary storage, both the engine switch and the fuel cap vent lever should be turned to “OFF” position, and the generator should be turned off. DO NOT move a running generator, turn it off then move to new location.

▲ WARNING

Transporting the Generator.

DO NOT overfill the fuel tank.

DO NOT use the generator inside the transport vehicle. The generator should be used in an open and well ventilated area.

Avoid exposure to direct sunlight when the generator is being transported in an enclosed transport vehicle. High temperatures inside the transport vehicle could cause fuel to vaporise resulting in a possible explosion.

Drain off the fuel, when the generator is transported on rough roads.

Storing for a long period:

9.1 Make sure the storage area is clean and dry.

9.2 Drain off the fuel.

▲ WARNING

Petrol is highly explosive and flammable, keep away from naked flames and all other sources of ignition.

a. Drain off the petrol in the fuel tank, and store in a suitable container.

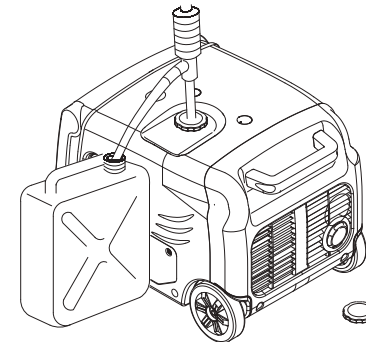

b. Turn the engine switch to “ON” position, and loosen the carburetor float bowl drain screw to discharge from inside of carburetor float bowl.

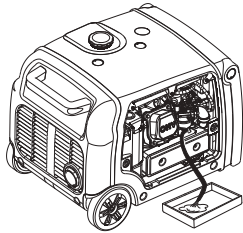

- c. Take off the spark plug cap, pull the recoil starter grip three or four times, discharge the petrol from the fuel pump and fuel lines.
- d. Turn the engine switch to “OFF” position, and tighten the drain screw of carburetor.
- e. Reinstall the spark plug cap.

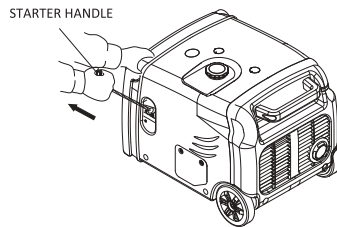

9.3 Change the engine oil.

9.4 Remove the spark plug, and pour a tablespoon of clean engine oil (10~20ml) into the cylinder. Revolve the engine several times to distribute the oil, and reinstall the spark plug.

9.5 Pull the starter grip slowly until you feel resistance. At this point, the piston is coming up on its compression stroke and both the intake and exhaust valves are closed. In this position, it helps to protect the engine from internal corrosion.

10.0 Troubleshooting.

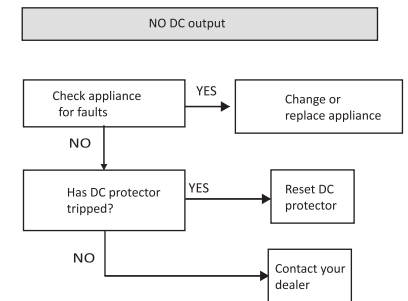
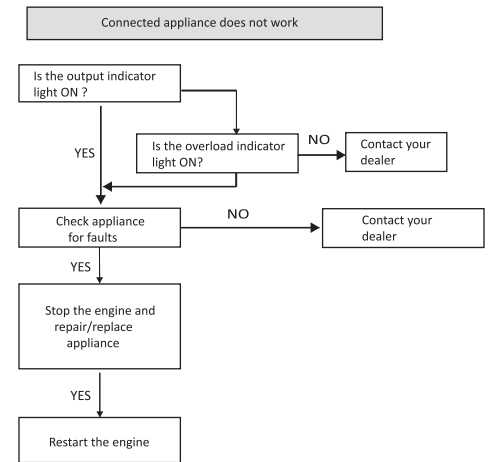
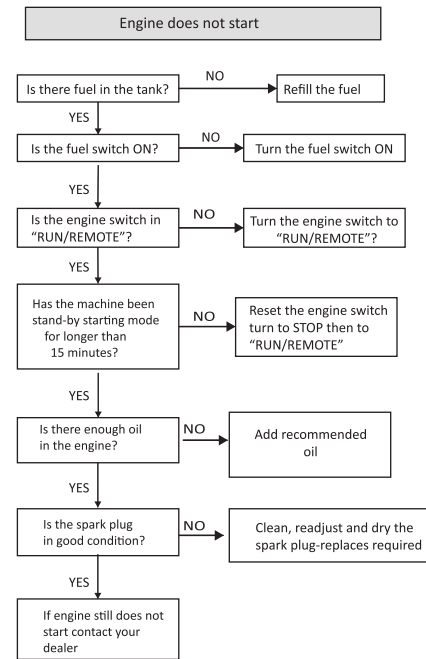

11.0 Technical Specifications

	SPECIFICATIONS	PARAMETERS		SPECIFICATIONS	PARAMETERS
ENGINE	Model	DJ170F	OTHER SPECIFICATIONS	DC output	12V/5A
	Type	4-stroke, overhead valve, single cylinder, forced-air cooling		Fuel volume	7.8L
	Engine displacement	208cc		Continuous running time	7.0hours
	Bore*Stroke	70.0mm * 54.0mm		Fuel consumption	490g/kW.h
	Compression ratio	8.5:1		Working ambient temperature	-20 C --40 C
	Rated power	4.0kW @ 3600min		Maximum altitude	1000m
	Ignition system	full transistor		Noise LwA	96dB
	Start methods	Recoil-Key-Wireless remote		Noise@7m	54--59dBA
	Fuel type-capacity	Unleaded petrol-7.8L		Dimensions	579mm*425mm*443mm
	Oil type-capacity	SAE15W-40-0.6L		Net weight	35kg
	GENERATOR	Model		HY3200SEi	
Rated frequency		50Hz			
Rated voltage		230V			
Max current		13.9A			
Rated speed		3600rpm			
Continuous output		2800W			
Maximum output		3200W			

12.0 Wiring Diagram.

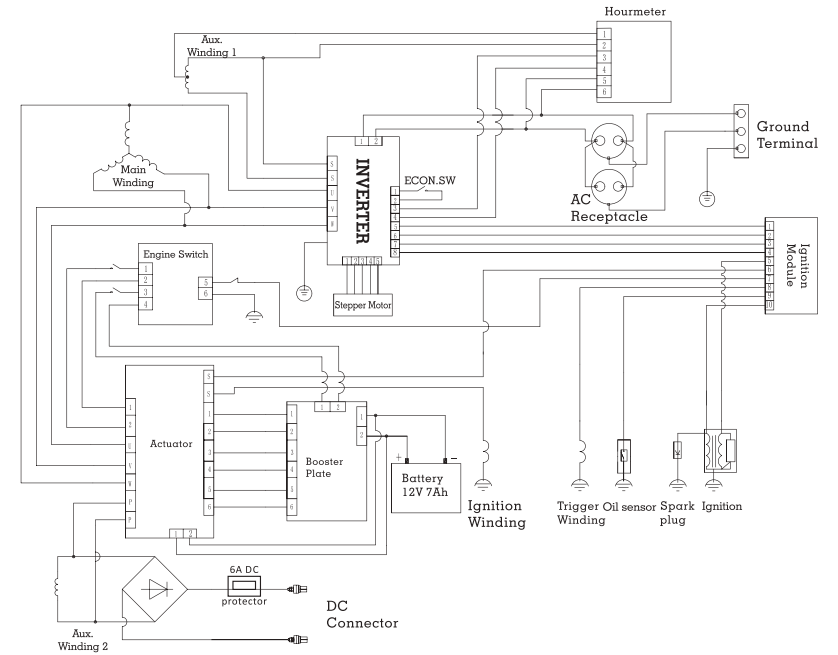

13.0 Appendix.

13.1 EC Declaration of Conformity

CE EC DECLARATION OF CONFORMITY CE

For the following machinery:

Product name: INVERTER GENERATOR

Model: HY3200SEi

is herewith confirmed to fulfill all the relevant provisions of Machinery Directive (2006/42/EC) and comply with Low-Voltage Directive (2006/95/EC & 2014/35/EU),

Electromagnetic Compatibility Directive (2004/108/EC & 2014/30/EU)

and Noise Emission Directive (2000/14/EC, amended by 2005/88/EC)

and the following harmonized standard have been complied with:

- EN 12601:2010;
- EN 61000-6-2:2005;
- EN 61000-6-4:2007

Responsible for marking this declaration is the:

Manufacturer Authorized representative established within the EU

Manufacture's Name : GENPOWER LTD
 Manufacturer's Address : Isaac Way, Pembroke Dock, Pembrokeshire, UK, Sa72 4RW

Authorized Rep's Name :
 Authorized Rep's Address :

Person responsible for compiling the technical files established within the EU
 Name, Surname: Kevin Stanley
 Address: GENPOWER LTD
 Isaac Way, Pembroke Dock, Pembrokeshire, UK, Sa72 4RW

Person responsible for making this declaration
 : Kevin Stanley
 Position/Title : Product Manager

13.2 Environmental Corrections.

The standard condition of rated power output;

Altitude; 0 metres

Ambient Temperature 25 °C

Relative humidity; 30%

Altitude (m)	Ambient temperature °C				
	25	30	35	40	45
0	1	0.98	0.96	0.93	0.90
500	0.93	0.91	0.89	0.87	0.84
1000	0.87	0.85	0.82	0.80	0.78
2000	0.75	0.73	0.71	0.69	0.66
3000	0.64	0.62	0.60	0.58	0.56
4000	0.54	0.52	0.50	0.48	0.46

NOTE

- Relative humidity 60% correction factor C- 0.01;
- Relative humidity 80% correction factor C -0.02;
- Relative humidity 90% correction factor C- 0.03;
- Relative humidity 100% correction factor C- 0.04;

NOTES

Example:

Rated power (Pn) 2.8 kVA generator (Altitude: 1000m) Ambient temperature: 35 °C

relative humidity: 80%

$$P=Pn *(C-0.02) = 2.8*(0.82-0.02) = 2.24kVA$$

13.3 Noise and Access.

Noise emission measure according to ISO 8528-10, EN ISO 3744, European Directive 2000/14/EC with amendment 2005/88/EC

Model of Generator Set: HY3200SEi

Guaranteed Sound Power Level: 96dB(A)

Measurement Uncertainty K: 1.7 dB(A)

The quoted figures are emission levels and are not necessarily safe working levels. Whilst there is a correlation between the emission and exposure levels, this cannot be used reliably to determine whether or not further precautions are required. Factors that influence the actual level of exposure of work-force include the characteristics of the work room, the other sources of noise, etc. i.e. the number of machines and other adjacent processes, and the length of time for which an operator is exposed to the noise. Also the permissible exposure level can vary from county. This information, however, will enable the user of the machine to make a better evaluation of the hazard and risk.

14.0 Consumer Information.

Consumer Service Information

Service dealers are trained professionally. They should be able to answer any questions you have.

If the dealer does not solve your problems, please discuss them with the manager of the dealer.

Most of your problems are solved in this way.

If you are dissatisfied with the decision of the manager of the dealer, contact the Customer Relations Department of Genpower Ltd.

NOTES

NOTES