



Operator's Manual

user manual, maintenance instructions and spare parts

415CSX PREMIUM Chainsaw



Read this manual carefully before operating the machine

Original Instructions Version July 18. E&OE

415CSX_030718

Component Location

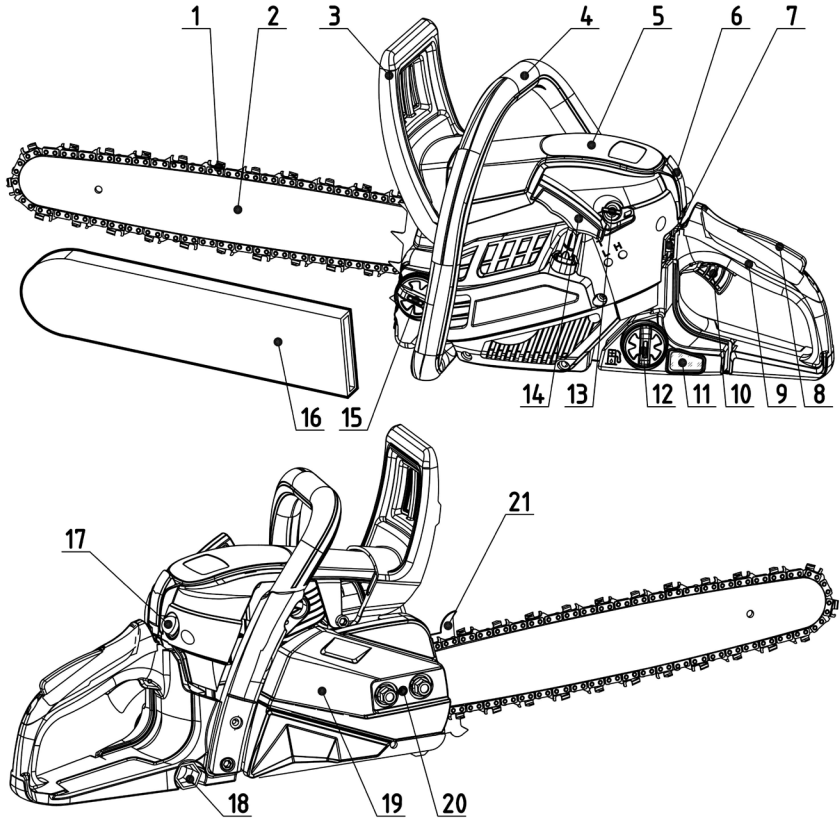

- | | | | | | |
|----|---------------------|-----|--------------------|-----|------------------|
| 1. | Saw chain | 9. | Rear Handle | 17. | Fuel Primer Bulb |
| 2. | Guide bar | 10. | Throttle Trigger | 18. | Integrated Tool |
| 3. | Chain brake | 11. | Fuel Level Window | 19. | Clutch Cover |
| 4. | Front handle | 12. | Fuel Tank Cap | 20. | Chain Tensioner |
| 5. | Air filter cover | 13. | Choke Lever | 21. | Felling Claws |
| 6. | Lock Lever | 14. | Starter Handle | | |
| 7. | Engine Switch | 15. | Chain Oil Tank Cap | | |
| 8. | Throttle lock lever | 16. | Guide Bar Cover | | |

PRODUCT DESCRIPTION

This Chainsaw is a 2 stroke fast running power tool and is designed to be used in a domestic application for cutting wood only. Do not cut metal, plastic or any non-wood materials.

Warnings in the Manual



This mark indicates instructions which must be followed in order to prevent accidents which could lead to serious bodily injury or death.





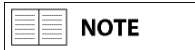

This mark indicates instructions which must be followed or it leads to mechanical failure, breakdown, or damage.



This mark indicates hints or useful directions in the use of the product.

Safety Symbols

Warning: Danger, Caution	
Read the documentation and safety instructions which are provided in this user manual	
When operating this machine, use protective equipment such as goggles, helmet and ear defenders	
Use the Chainsaw with two hands	
Beware: Keep hands and feet away from moving parts. Always keep a safe distance from the cutting parts	
Beware of objects being thrown from the operating zone	
Warning! Danger of Kickback	

Directive 2000-14/CE. Guaranteed noise levels	
Danger: Risk of intoxication	
Danger: Risk of fire or explosion	
Hot surface, risk of burn	

Taking Care of Warning Labels

Always keep warning labels clean and free of scratches, which might make them illegible or difficult to read. If the warning labels provided with your Chainsaw become damaged, peel off, or otherwise become illegible or difficult to read, order new labels from the authorised servicing dealer and replace the damaged labels. When applying new labels, first wipe away any dirt and dry the surface before applying the new label in the same place as the original label.

Explanation of Symbols on the Machine

For safe operation and maintenance, symbols are carved in relief on the machine.



FUEL TANK

2 stroke mix
Position: Fuel cap



CHAIN OIL TANK

Position: oil cap



STOP SWITCH

Setting the switch to the "0" position, the engine stops immediately.
Position: Rear-left of the unit



CHOKE OPERATION
<RUN>

Starting mode when the engine is hot.
Position: Upper-left of the air cleaner cover



<START>

Starting mode when the engine is cold.
Position: Upper-left of the air cleaner cover



HIGH-SPEED ADJUSTMENT SCREW

Position: Left side, screw under "H" stamp



SLOW-SPEED ADJUSTMENT SCREW

Position: Left side, screw under "L" stamp



IDLE ADJUSTMENT SCREW

Position: Left side, screw under "T" stamp

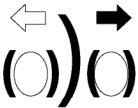

CHAIN BREAK RELEASE / ACTIVATION

Released (white arrow) and Activated (black arrow).
Position: Front of the chain cover

Safety Precautions

Read this Owner/Operator Manual carefully. Be sure you understand how to operate this Chainsaw properly before you use it. Failure to do so could result in serious injury.

Keep this manual handy so that you may refer to it later whenever any questions arise. Also note that you are able to contact your authorised MITOX® dealer for assistance.

Always include this manual when selling, lending, or otherwise transferring the ownership of this product.

This product has been designed to be used as a Chainsaw power tool as described previously and it should never be used for any other purpose; doing so could result in unforeseen accidents and injuries occurring. Only approved MITOX® accessories should be used with this product.

This Chainsaw is equipped with an extremely sharp blade, always wear sturdy gloves when handling the blades and fit the safety guards when not in use.

When using this Chainsaw for the first time, take it to a wide, clear, open space, start the engine, and practice handling the Chainsaw until you are sure that you will be able to handle it properly in actual operation.

You should never use this Chainsaw when under the influence of alcohol, suffering from exhaustion or lack of sleep, suffering from drowsiness as a result of having taken medicine, or at any other time when your judgement might be impaired or that you might not be able to operate the Chainsaw properly and in a safe manner.

Never allow children or anyone unable to fully understand the directions given in this manual to use this Chainsaw.

When planning your work schedule, allow plenty of time to perform the work and allow plenty of time for rest. Limit the amount of time you continuously use this product to 30-40 minutes per session and take 10-20 minutes of rest between work sessions. Also, try to keep the total amount of work performed in a single day to 2 hours.

Never run the engine indoors as the exhaust gases contain harmful carbon monoxide.

Never use this Chainsaw in the conditions described below:

When the ground is slippery or when other conditions exist which might make it difficult to maintain a steady posture while using this product.

At night, at times of heavy fog, or at any other time when your field of vision is limited and it would be difficult to gain a clear view of the area where it is to be used. In heavy rain, during lightning storms, at times of strong or gale-force winds or at any other time when the weather conditions might make it unsafe to use this product.

Work Clothing & Safety Equipment

When using this product, you should wear the correct Personal Protective Equipment.

- Helmet
- Safety goggles / face protector
- Ear protection
- Thick work gloves
- Non-slip, steel toe capped work boots
- Strong, durable work clothing; shirts should be long sleeved and trousers should be full length

Safety and Operation

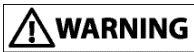

Improper handling can cause accidents which may in turn lead to serious injury or death. Always adhere to the following instructions when using this product:

- Never hold this product with the cutting head pointing towards someone else.
- Never allow the blade/blades to come into contact with your body.
- Always turn off the engine before making adjustments or when coming close to the cutting head.

Before Starting Work

Carefully check the work area and remove any obstacles. A perimeter of 15 metres of the work area should be considered a hazardous area, into which no-one should enter while this product is being used. When necessary this area should be marked with a warning rope, warning signs or other forms of warning.

If work is to be carried out by two or more operators, care should be taken to constantly check the location of other operators within the work area, to maintain a safe distance between each operator.

Before starting work all components of this product should be checked to make sure that it is in proper working order. Ensure there are no loose screws or bolts, fuel leaks, ruptures, dents, broken guards or any other problems which might affect the safe operation.

Keep all parts of your body away from the cutting head when the engine is running.

Before Starting the Engine

Place your machine on the ground in a flat, clear area and hold it firmly to ensure that neither the cutting head or throttle come into contact with any obstacles when the engine starts.

After Starting the Engine

Ensure the cutting head stops moving when the throttle trigger is released (idle). If the cutting head continues to move when the engine is at idle, adjust the idle screw on the carburettor to a point where the cutting head stops moving. If this cannot be achieved, take your machine to your authorised MITOX® dealer for adjustment.

Avoid Noise Problems

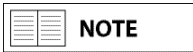

Check and follow the local regulations for sound levels and hours of operation for garden machinery. In general, operate garden machinery between 8am and 5pm weekdays and 9am and 5pm weekends. Avoid using garden machinery early in the morning and/or late at night.

Safety During Operation



When using your Chainsaw, grip the handles firmly with both hands, place your feet slightly apart so your weight is distributed evenly across both legs and always be sure to maintain a steady even posture while working. Do not use on ladders or if the ground surface is slippery or uneven. Never attempt to cut overhead or with one hand.

- Maintain full engine speed when cutting.
- Never allow other persons to come within the work area as doing so might expose them to danger.
- If a branch or other object gets caught in the blades during operation, always turn off the engine before removing the object.
- To protect yourself against injury from falling branches, wear the required safety equipment.
- Keep the operation area clear of all persons, particularly small children and pets. Injury may result from flying debris.
- Never touch the spark plug or plug HT cable while the engine is in operation, doing so may result in an electrical shock.
- Never touch the exhaust, spark plug or any metallic parts of the engine while the engine is in operation or immediately after shutting down the engine. These parts reach high temperatures during operation and doing so could result in serious burns.
- When you finish cutting in one location and wish to continue work in another area, turn off the engine, place the protective cover over the blades, and turn the chain saw so that the blades face away from your body before carrying it to the new location.
- Always remove fuel from the fuel tank before transportation to prevent fuel spillage.
- When not in use never leave the chain saw exposed to direct sunlight as this can heat the fuel tank and may cause a discharge of fuel, and flood the engine.



In the Box

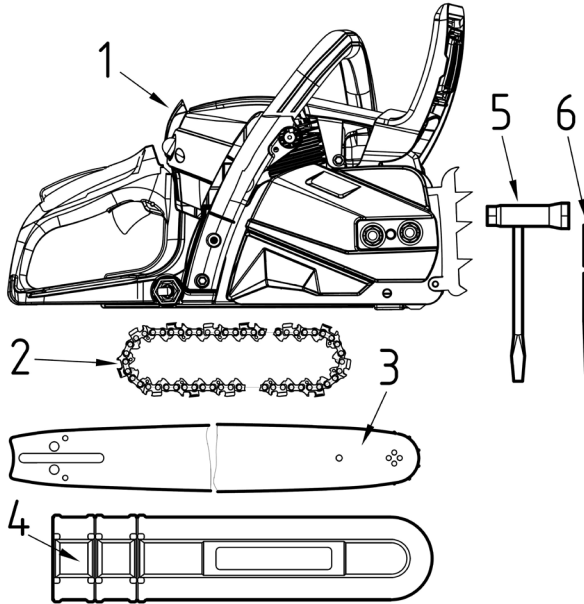

A standard saw unit package contains the items as illustrated

- 1) Power unit
- 2) Saw chain
- 3) Guide bar
- 4) Bar protector
- 5) Plug wrench
- 6) Chain File

Not pictured

- 7) Owner's manual

Safe Handling of Fuel



The engine of the Chainsaw is designed to run on a two stroke oil/fuel mixture.

This fuel is highly flammable; never store cans of fuel or refill the fuel tank in any place where there is a source of heat or fire, which might ignite the fuel.

Do not smoke whilst operating or refilling the Chainsaw, keep lit cigarettes away from the Chainsaw at all times.

When refilling the fuel tank always stop the engine first and carefully make sure that there are no sparks or naked flames anywhere nearby before refuelling.

If any fuel spillage occurs during refuelling, use a dry rag to wipe any fuel which has been spilled onto the Chainsaw before starting the engine.

After refuelling, screw the fuel cap back tightly onto the fuel tank and carry the Chainsaw to a spot 5 metres or more away from where it was refuelled before starting the engine.

Two-Stroke Fuel



Fuel is very flammable. Do not smoke or bring any flame or sparks near fuel.

The engine is lubricated by oil mixed into petrol. Prepare a mixture of unleaded petrol and semi-synthetic two-stroke oil that meets the specifications of: API TC, ISO-L-EGC, JASO FC (Low Smoke) oil.

Recommended mixing ratio is 40:1.

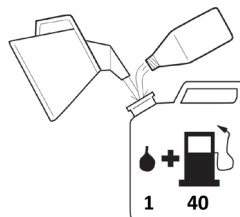

FUEL WITH NO OIL (RAW PETROL) will cause severe damage to the engine which is not covered by the manufacturer's warranty.

Use fresh, unleaded petrol (95 RON) and semi-synthetic oil specially made for high performance two-stroke engines. Mix in a ratio of 40 parts petrol to 1 part of oil.

By using two-stroke oil specially made for two-stroke engines you will reduce the formation of ash and carbon deposits on the spark plug, piston, exhaust muffler and cylinder as well as reducing emissions of harmful exhaust gases.

Oil FOR 4-CYCLE ENGINES should not be used as two-stroke lubrication oil as it can cause fouling of the spark plug, exhaust port blocking, piston ring sticking and other internal engine damage.

 **NOTE**

Due to increased Ethanol content in petrol we recommend the use of B3C Ethanol Shield 2-Stroke Oil, or Ethanol Shield Fuel Stabiliser to protect your MITOX® engine against the harmful effects of Ethanol.

Visit www.b3cfuel.co.uk for more information.



 **IMPORTANT**

Fuel Storage (Without Ethanol Shield)

Mixed two-stroke fuel which has been left unused for a period of one month or more may damage the carburettor and result in the engine failing to start or operate correctly.

When storing the Chainsaw for a period of more than one month, empty the fuel tank and run the engine to empty the carburettor of fuel.

Two-stroke fuel can cause deterioration of rubber and/or plastic components during prolonged storage.

It is important to only use good quality, fresh fuel.

Fuelling

Shake the fuel container to thoroughly mix the two-stroke oil and petrol.

Clean dirt from around the fuel cap before removing.

Pour two-stroke fuel into the fuel tank with a filtered funnel, up to 80% of the fuel tank's capacity.

Replace the fuel cap and tighten securely. Spilled fuel must be wiped away from the Chainsaw before starting the engine.

Move at least 5m away from the refuelling area before restarting the engine.



When refilling the tank, always turn off the engine and allow it to cool down. Take a careful look around to make sure that there are no sparks or open flames anywhere nearby before refuelling.

Chain Oil

Use only specialist anti fling chain oil. Fill the chain oil tank every time you fill the fuel tank.

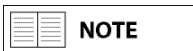

Do not use waste or regenerated oil that can cause damage to the oil pump.

Installing the Guide Bar and Chain

Open the box and install the guide bar and the saw chain on the power unit as follows:
The saw chain has very sharp edges. Use thick protective gloves for safety.

1. Pull the chain brake towards the front handle to check that the chain brake is not on.
2. Loosen the nuts and remove the chain cover.
3. Install the spike to the power unit (dependent on model).
4. Remove and discard the plastic packer located on the bar studs.
5. Fit the guide bar over the bar bolts.

Figure 1.

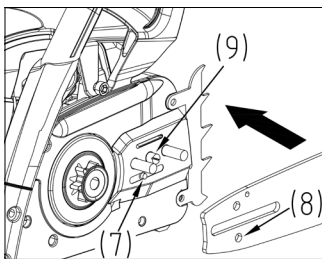
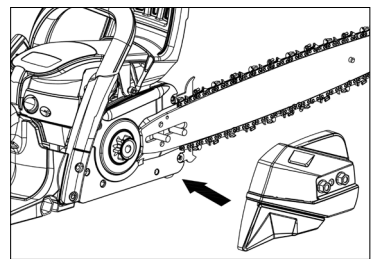

Figure 2.



Chain Direction

6. **Figure 1.** Fit the chain to the drive sprocket and while fitting the saw chain around the guide bar, adjust the position of the chain tensioner located in position 7 to fit into the hole (8) in the guide bar. 9 shows the chain tensioner screw.
7. Fit the chain cover to the power unit and fasten the nuts finger tight.
8. **Figure 2.** While holding up the tip of the bar, adjust the chain tension by turning the tensioner screw (9) until the chain does not sag from the underside of the guide bar.
9. Tighten the bar nuts securely with the bar held up to 12/15N.M, then check the chain for smooth rotation and proper tension while moving the chain by hand.

Note: A new chain will expand in length at the beginning of use. Check and readjust the tension frequently, as a loose chain can easily derail or cause rapid wear to itself and the guide bar.

Chain Brake

This machine is equipped with an automatic brake to stop the saw chain rotation upon the occurrence of kickback during saw cutting. The brake is automatically operated by inertial force, which acts on the weight fitted inside the front guard. The brake can also be operated manually by pushing the chain brake forward towards the guide bar.

To release the brake, pull back the chain brake (4) toward the front handle (1) until a “click” sound is heard (2).

How to check:

You must check the chain brake operation before each usage by running the saw at full throttle for 1-2 seconds and pushing the front hand guard (4) forward (3).

The chain should stop immediately with the engine at full speed.

If the chain is slow to stop or does not stop, replace the brake band and clutch drum before use.

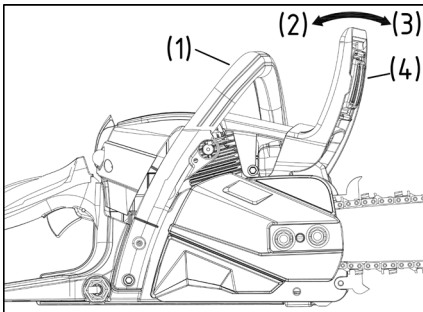

Before proceeding to your job, it is recommended to first practice sawing easy logs. This also helps you get accustomed to your unit.

Always follow the safety regulations:

The chainsaw must only be used for cutting wood. It is forbidden to cut other types of material. Vibrations and kick-back vary with different materials and the requirements of the safety regulations would not be met. Do not use the chainsaw as a lever for lifting, moving or splitting objects. The saw should cut easily without force. Apply only light pressure while running the engine at full throttle.

When the saw chain is caught in the cut, do not attempt to pull it out by force, but use a wedge or a lever to sufficiently open the gap in the wood.

Kickback Safety Precautions

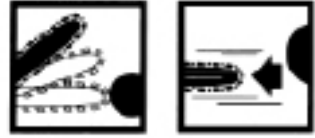

Kickback may occur when the nose or tip of the guide bar touches an object, or when the wood closes in and pinches the saw chain in the cut. Top contact in some cases may cause a lightning fast reverse reaction, kicking the guide bar up and back towards the operator. Pinching the saw chain along the top of the guide bar may push the guide bar rapidly back towards the operator. Either of these reactions may cause you to lose control of the saw which could result in serious personal injury.

Do not rely exclusively on the safety devices built into your saw. As a chain saw user you should take several steps to keep cutting jobs free from accident or injury.

1. With a basic understanding of kickback you can reduce or eliminate the element of surprise. Sudden surprise contributes to accidents.
2. Keep a good grip on the saw with both hands, the right hand on the rear handle, and the left hand on the front handle, when the engine is running. Use a firm grip with thumbs and fingers encircling the chainsaw handles. A firm grip will help you reduce kickback and maintain control of the saw.
3. Make certain that the area in which you are cutting is free from obstructions. Do not let the nose of the guide bar contact a log, branch, or any other obstruction which could be hit while you are operating the saw.
4. Cut at high engine speeds.
5. Do not overreach or cut above shoulder height.
6. Follow the manufacturer's sharpening and maintenance instructions for saw chain.
7. Only use replacement bars and chains specified by the manufacturer.

It is important to maintain the proper chain tension. Rapid wear of the guide bar or the chain coming off can be caused by improper tension, especially when using a new chain.

Operating the Engine

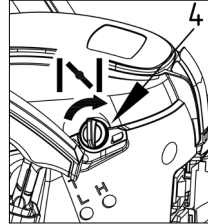
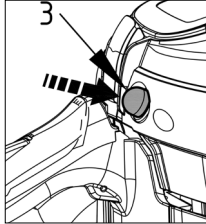
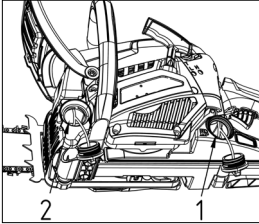

1. Fill fuel (1) and chain oil (2) tanks respectively, and tighten the caps securely.
2. Press the primer button (3) 6 times.
3. Turn choke lever clockwise (4). The choke will close and the throttle will be set in the starting position.
4. Apply the chain brake (7) by pushing the chain brake forwards.
5. Place the saw on the ground, grip the front handle with your left hand, place your right foot through the rear handle. Pull the starter handle with your right hand. **Caution: Do not pull the starter cord all the way out and do not let go of the starter handle if the cord is extended, this can damage the mechanism.**

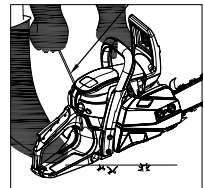
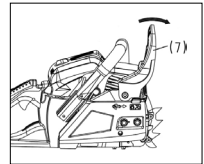

8. When the engine has tried to fire, turn choke lever anticlockwise (4) and then pull the starter handle again to start the engine.
9. As soon as the engine is running, pull the throttle lever slightly to reset the throttle control to idle. This must be done as soon as the engine has started to avoid unnecessary wear on the clutch.

NOTE: Disengage the chain brake by pulling the chain brake towards the front handle prior to cutting.

Hot Engine Start

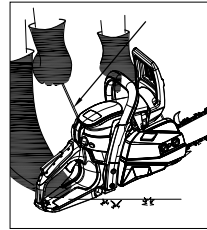
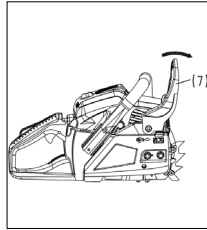
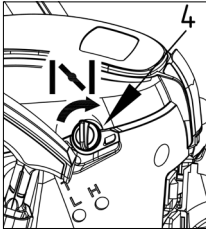

1. Turn choke lever clockwise (4), then turn anticlockwise, this will set the choke to the hot start position.
2. Apply the chain brake (7) by pushing the chain brake forwards.
3. Pull the starter handle until the engine runs.
4. Pulling the throttle lever slightly will reset the throttle control.

Disengage the chain brake by pulling the chain brake towards the front handle prior to cutting.

Running In

During the first ten hours of work, avoid running the engine at maximum speed for a prolonged period until all the components have bedded in. After the engine has been run in, it will reach its maximum power. After two hours of work, check that all nuts and screws are securely fastened and tighten if necessary.

Stopping the Engine

1. Release the throttle lever and allow the engine to run at idle for half a minute.
2. Set the ignition switch to the STOP position ("0"). **Except for an emergency, avoid stopping the engine while at full throttle.**

Checking the Oil Supply

After starting the engine, run the chain at medium speed and see if chain oil is sprayed as shown in the figure.



Care and Maintenance of Your Chainsaw

- In order to maintain your chainsaw in good working order, perform the maintenance and checking operations described in this manual at regular intervals. In the event that any part needs to be replaced, please contact the nearest authorised service dealer for assistance.
- Always turn off the engine before performing any maintenance or checking procedures.
- When sharpening, removing, or reattaching the blades, be sure to wear thick, sturdy gloves and use only appropriate tools and equipment to prevent injury.
- When replacing blades or any other parts, be sure to use only genuine spare parts and approved lubricants.

Maintenance

! IMPORTANT

- After every use, check that all nuts, bolts and screws are securely fastened and tighten if necessary.
- In the event of an accident, breakdown or blockage, ensure the engine is turned off before any work is carried out to rectify this.
- Make sure the engine has stopped and is cool before performing any service to the machine. Contact with moving cutting head or hot muffler may result in a personal injury. Always wear heavy-duty gloves when handling the blades.

Maintenance After Each Use

Air filter

- A. Pull out the top side of lock lever (1) (step1), then pull the lock lever upwards to unlock it (step 2).
- B. Pull out the cylinder shield (2) rearwards and remove it.
- C. Push in the knob of lock rod (3) forward to loosen it.
- D. Remove the air filter (4).

Dust on the air cleaner surface can be removed by tapping a corner of the cleaner against a hard surface. To clean dirt in the meshes, split the cleaner into halves and brush off the dust lightly or wash in non-flammable solvent, or replace the air filter. To assemble the cleaner halves, press until it clicks.

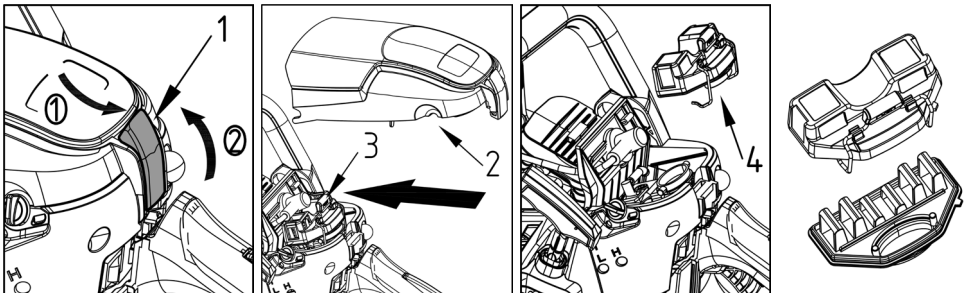

Maintenance After Each Use

Oiling port

Dismount the guide bar and check the oiling port (1) for clogging.

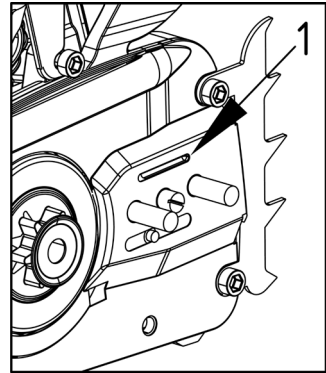

Guide bar

When the guide bar is dismantled, remove sawdust from the bar groove and the oiling port.

Grease the nose sprocket with a sprocket grease gun (Oregon part number 21939)

1. Guide bar groove
2. Oil hole
3. Drive sprocket
4. Grease point

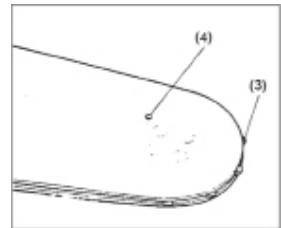
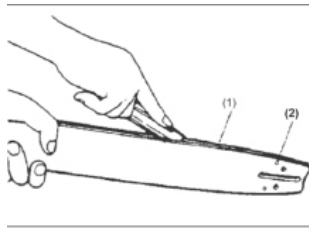

Reverse guide bar occasionally to prevent partial wear. The bar rail should always be square. Check for wear of the bar rail. Apply a ruler to the bar and the outside of the cutter. If a gap is observed between them, the rail is normal. Otherwise, the bar rail is worn. Such a bar needs to be replaced.

1. Ruler
2. Gap
3. No gap
4. Chain tilts

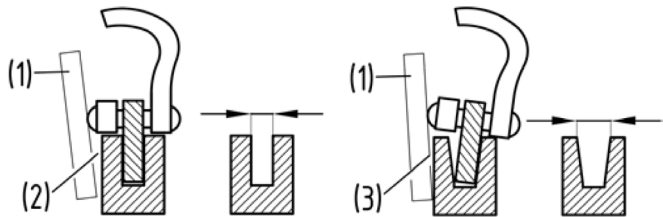

Other Checks

Check for fuel leakage and loose fastenings and damage to major parts, especially handle joints and guide bar mounting. If any defects are found, make sure to have them repaired before operating the saw again. Check for cracks and for excessive wear interfering with the chain drive. If the wear is considerable, replace it with a new one. Never fit a new chain on a worn sprocket, or a worn chain on a new sprocket.

Periodical Service Points

Cylinder Fins

Dust clogging between the cylinder fins will cause overheating of the engine.

Periodically check and clean the cylinder fins after removing the cylinder cover.

When installing the cylinder cover, make sure that switch wires and grommets are fitted correctly.

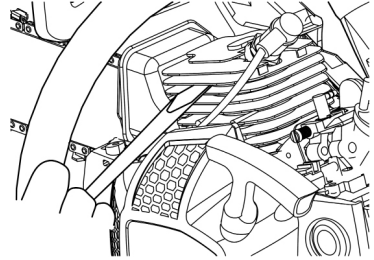

Fuel filter

Using a wire hook, take out the filter (20) from the filler port.

Disassemble the filter and clean with petrol, or replace with a new one if needed.

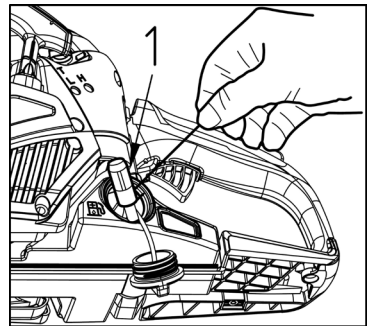

Spark plug

Clean the electrodes with a wire brush and reset the gap to 0.65 mm as necessary.

Plug type: CHAMPION RCJ7Y / NGK BPMR7A

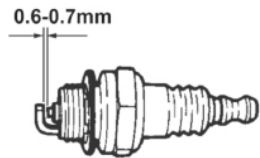

Sprocket

Check for cracks and for excessive wear interfering with the chain drive. If the wear is considerable, replace it with a new one. Never fit a new chain on a worn sprocket, or a worn chain on a new sprocket.

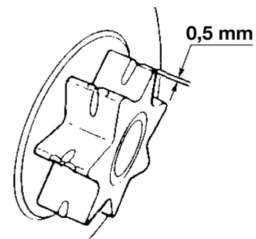

Adjusting Oil Flow Rate

Never fill the oil reservoir or adjust the oiler with the engine running.

An increase in bar oil flow rate will speed oil consumption, requiring more frequent checks on the oil reservoir. To ensure sufficient lubrication, it may be necessary to check the oil level more frequently than at fuel tank refills. The guide bar and chain are lubricated automatically by a pump that operates whenever the chain rotates. The pump is set at the factory to deliver a minimum flow rate, but it can be adjusted in the field. A temporary increase in oil flow is often desirable when cutting hardwood.

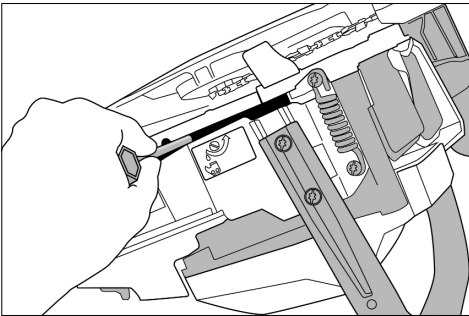

Adjust the pump as follows:

1. Stop the engine and make sure the stop switch is in the OFF position.
2. Place the unit on its side with the sprocket side and chain brake assembly facing up.
3. With a screwdriver, push in on the oil flow rate adjusting screw and turn in the desired direction: Clockwise-decrease lubrication / Counter clockwise-increase lubrication.

Saw Chain Sharpening

The chain needs to be sharpened when:

1. Sawdust becomes powder-like.
2. The cut path does not go straight.
3. Fuel consumption increases.
4. You need extra force to saw with.
5. Vibration increases.

Be sure to wear safety gloves.

- Clamp chain saw guide bar in a vice to secure.
- Sharpen chain with a 5/32 (4mm) file and holder (Oregon part number 16265) / Sharpening kit (Oregon part no 90405)
- Place your file on the cutter and push straight forward. Keep the file position.
- After every cutter has been set, check the depth gauge and file it to the proper level.
- Make sure every cutter has the same length and edge angles as illustrated.

	File diameter	Top plate angle	Down angle	Depth gauge standard
Type of chain	 4 mm	 30°	 90°	 0.025°
72LPX	5/32"	30°	90°	0.025°
 Depth gauge		 File		

Anti Freezing Window

Operating chain saws in temperatures of $-25^{\circ}\text{C} - 0^{\circ}\text{C}$ at times of high humidity may result in ice forming within the carburetor, and this in turn may cause the output power of the engine to be reduced or for the engine to fail to operate smoothly.

This product has accordingly been designed with an anti-freezing window on the top right of the carburettor supporter to allow warm air to be supplied to the carburettor chamber and to thereby prevent icing from occurring.

- Under normal circumstances the anti-freezing window should be set in the close mode.
- However when the possibility exists that icing may occur, the anti-freezing window should be set in the open mode before use.

Continuing to use the product in the anti-freezing mode even when temperatures have risen and returned to normal, may result in the engine failing to start properly or in the engine failing to operate at its normal speed, and for this reason you should always be sure to set the anti-freezing window to the close mode if there is no danger of icing occurring.

1. Remove cylinder cover and air filter
2. Pinch the anti-freezing window (5) and pull it out, then turn it over and push it into the carburettor supporter again.
3. Reinstall the air filter and cylinder shield and lock it securely.

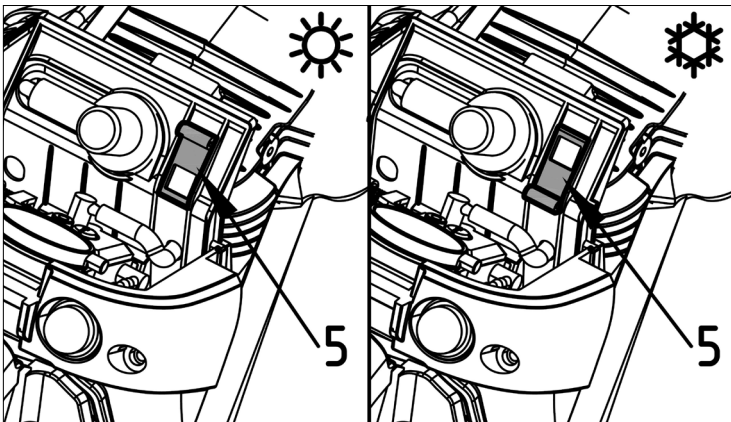

Service Schedule

Component	Procedure	Before Use	Every 25 Hours	Every 50 Hours	Every 100 Hours	Note
Fuel Leaks / Fuel Spillage	Wipe Out	•				
Fuel Tank / Fuel Filter	Inspect / Clean	•	•			Replace if Neccessary
Idle Adjusting Screw	See Adjusting Carburettor	•				Adjust if Neccessary
Spark Plug	Clean and Readjust Plug Gap			•		Gap 0.025in (0.6-0.7mm) Replace if Neccessary
Cylinder Fins / Intake Air Cooling Vent	Clean		•			
Muffler / Spark Arrestor / Cylinder Exhaust Port	Clean			•		
Throttle Lever / Ignition Switch	Check Operation	•				
Air Filter	Clean	•				
Screws / Nuts / Bolts	Tighten / Replace	•			•	Except Adjusting Screws
Oiling Port	Clean	•				
Guide Bar	Clean	•				
Sprocket	Inspect / Replace			•		
Saw Chain	Inspect / Sharpen	•				

Troubleshooting: Power loss or engine stopping.

- Check that the fuel tank is not empty.
- The mixture does not reach the carburettor. Change the fuel filter in the fuel tank.
- There is water in the mixture. Drain then clean the fuel system .
- The air filter is dirty. Clean the air filter.
- There are carbon deposits in the cylinder exhaust pipe or muffler. Clean or change muffler.
- Spark plug is worn. Replace spark plug.

Specifications

Power unit

Displacement

415CSX..... 41.4cc

Maximum engine power

415CSX..... 1.85kW

Fuel.....Mixture (Unleaded Petrol 40 : two-stroke oil 1)

Fuel tank capacity..... 550ml

Chain oil.....Anti-fling Chain Oil

Oil tank capacity.....260ml

Carburettor..... Diaphragm type

Fuel consumption at maximum engine power..... 530g/kw-h

Idling speed..... 3000r/min

Maximum speed with cutting attachment..... 12000r/min

Ignition system.....C.D.I. with timing advance function

Spark plug.....NGK BPMR7A / CHAMPION RCJ7Y / BOSCH L8RTF

Oil feeding system.....Mechanical plunger pump with adjuster

Sprocket Teeth x Pitch

415CSX.....6Tx3/8in

Dimensions (L x W x H).....420x250x280(mm)

Dry weight (without guide bar and chain, empty tanks): 5.2kg



Specifications

Cutting gear

Guide bar

Type.....Sprocket nose

Size

415CSX.....16"

Cutting length

415CSX.....370mm(16")

Saw chain

Type.....Oregon 91PX

Pitch.....0.375"

Gauge.....0.050" / 1.27mm

415CSX Parts - Engine

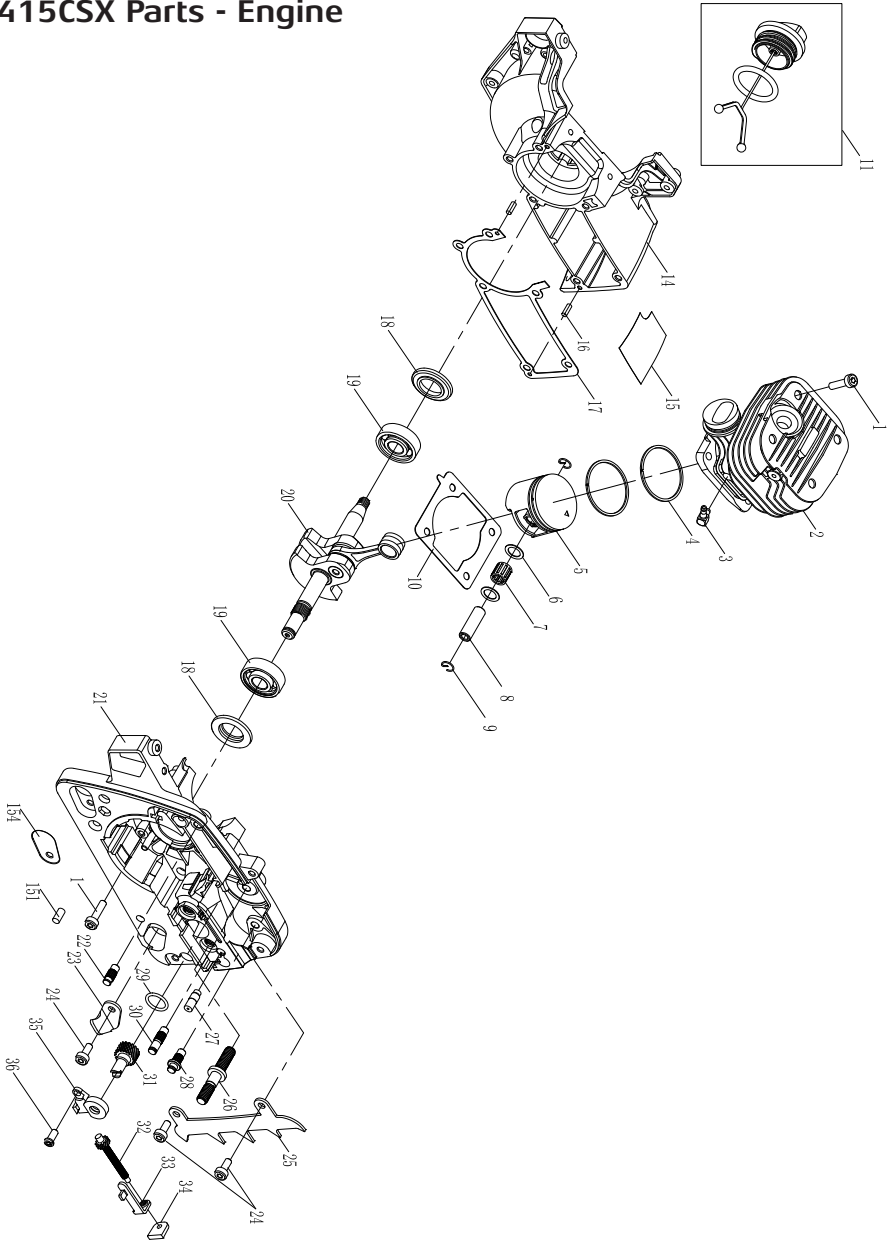

415CSX Parts - Engine

NO.	PART NO.	DESCRIPTION	QTY
1	MIO1.01.2141	SCREW M5x20	10
2	MIA41.1101.0003	CYLINDER	1
3	MIA25.0102.0200	PRESSURE NOZZLE	1
4	MIA41.1103.0001	PISTON RING	2
5	MIA41.1103.0300	PISTON	1
6	MIA42.1103.0004	NEEDLE BEARING GASKET	2
7	MIA41.1103.0400	NEEDLE BEARING 9x 12x12	1
8	MIA42.0103.0002	PISTON PIN	1
9	MIA42.0103.0003	CIRCLIP	2
10	MIA42.0101.0005	CYLINDER GASKET	1
11	MIA41.1111.0300	FUEL TANK CAP ASSEMBLY	2
14	MIA42.0102.0002-12	LEFT CRANKCASE	1
15	MIA42.0102.0007-1	HEAT SHEILD	1
16	MIO1.05.0140	PIN Ø3x10	2
17	MIA42.0102.0003	CRANKCASE GASKET	1
18	MIA42.0102.0200	OIL SEAL	2
19	MIA42.0102.0100	BEARING	2
20	MIA42.0103.0100	CRANKSHAFT	1
21	MIA42.0102.0001-12	RIGHT CRANKCASE	1
22	MIA42.0102.0004	PIN	1
23	MIA41.1100.0002	CHAIN CATCHER	1
24	MIA42.0100.0008	SCREW M5x16	14
25	MIA42.0101.0013	SPIKED BUMPER	1
26	MIA41.1102.0008	BAR STUD	2
27	MIA42.0102.0300	VENT NOZZLE	1
28	MIA42.0102.0005	PIN	1
29	MIO3.01.2.173	O RING 6x2	1
30	MIA42.0102.0006	PIN	1
31	MIA42.0112.0007	TENSIONER GEAR	1
32	MIA42.0112.0008	TENSIONER SCREW	1
33	MIA42.0112.0009	TENSIONER BLOCK	1
34	MIA42.0112.0006-1	POSITION BLOCK	1
35	MIA42.0112.0005-1	GEAR COVER	1
36	MIO1.01.3061	SCREW M4x10	1
151	MIO1.05.0072	OIL PUMP PIN 5x14	1
154	MIA42.0100.0010	COVER	1

415CSX Parts - Intake & Exhaust

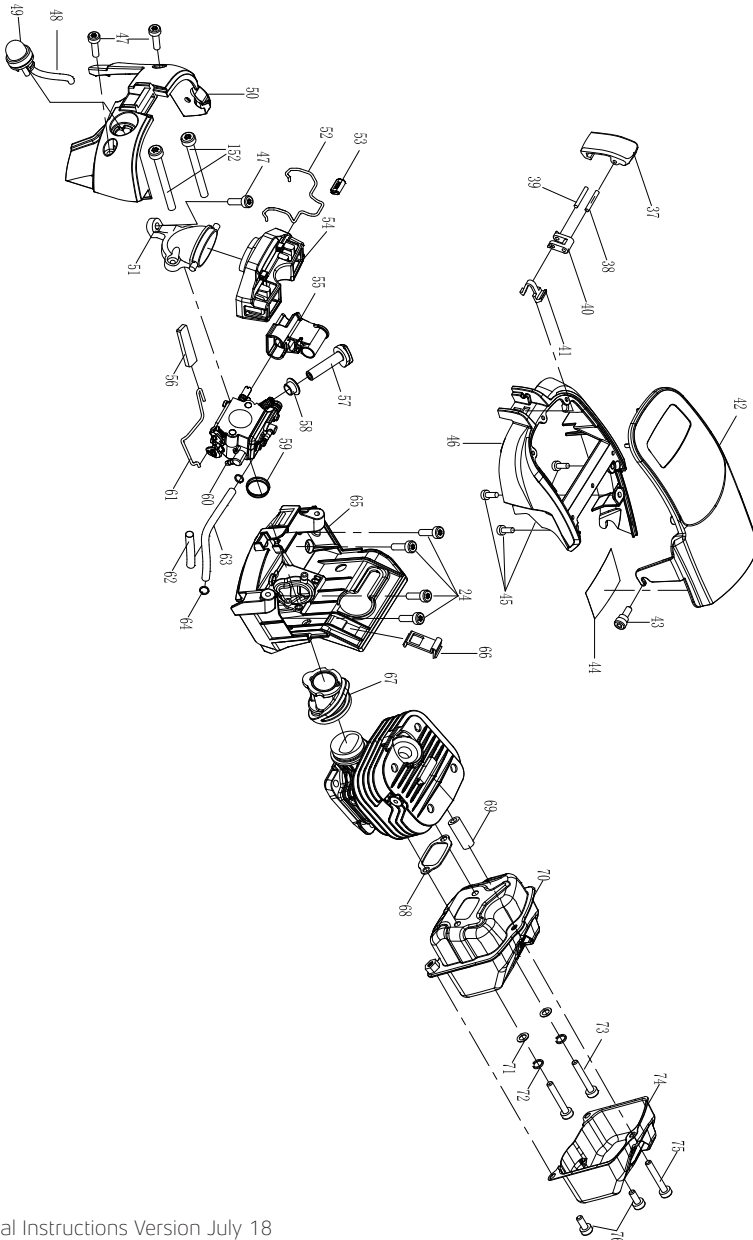

415CSX Parts - Intake & Exhaust

NO.	PART NO.	DESCRIPTION	QTY
37	MIA41.1113.0007-9	LOCK LEVER	1
38	MI01.05.0242	PIN 3x22	2
39	MI01.05.0243	PIN 3x23	1
40	MIA41.1113.0009-1	TRANSFER BAR	1
41	MIA41.1113.0008-1	HOOK	1
42	MIA41.1113.0003-2	SUPPORT COVER	1
43	MIA41.1112.0003	POSITION SCREW	2
44	MIA41.1113.0002	HEAT SHEILD	1
45	MI01.01.1391	TAPPING SCREW ST4.2x10	6
46	MIA41.1113.0001-4	TOP COVER	1
47	MIA50.5100.0009	TAPPING SCREW ST4.8x16	12
48	MI03.01.2.153	PUMP PIPE 2.5x 5x85	1
49	MIA38.0311.0100	PRIMER BULB	1
50	MIA41.1113.0006-5	REAR COVER	1
51	MIA41.1101.0300	AIR FILTER BASE	1
52	MIA41.1104.0001	LOCKING SPRING	1
53	MIA41.1104.0002-1	LOCK KNOB	1
54	MIA41.1104.0100	AIR FILTER	1
55	MIA41.1113.0004-1	L/H GUIDE	1
56	MIA41.1100.0006	THROTTLE KNOB	1
57	MIA41.1100.0010-12	CHOKE KNOB	1
58	MIA41.1100.0011	CHOKE KNOB BASE	1
59	MIA42.0101.0002	SUPPORT RING	1
60	MI06.08.02.21A	CARBURETTOR	1
61	MIA41.1100.0015	THROTTLE ROD	1
62	MI03.01.2.025	HEAT ISOLATION TUBE	1
63	MI03.01.2.154	RETURN PIPE 2.5x 6x130	1
64	MIA45.0102.0103	CIRCLIP	5
65	MIA41.1101.0200	CARBURETTOR SUPPORT	1
66	MIA41.1113.0005	SCREEN	1
67	MIA42.0101.0004	INTAKE PIPE	1
68	MIA42.0101.0006	MUFFLER GASKET	1
69	MI06.06.277	SUPPORT TUBE	1
70	MIA41.0105.0100	MUFFLER	1
71	MI01.04.0121	PLAIN WASHER	2
72	MI01.04.0091	SPRING WASHER	2

NO.	PART NO.	DESCRIPTION	QTY
73	MIA50.1105.0113	SCREW M5x20 12.9	2
74	MIA41.0105.0001	MUFFLER COVER	1
75	MIA42.0105.0003	SCREW M5x40	1
76	MI01.01.3303	SCREW M5x12	4
152	MIA42.0101.0001	SCREW M4X40	2

415CSX Parts - Recoil

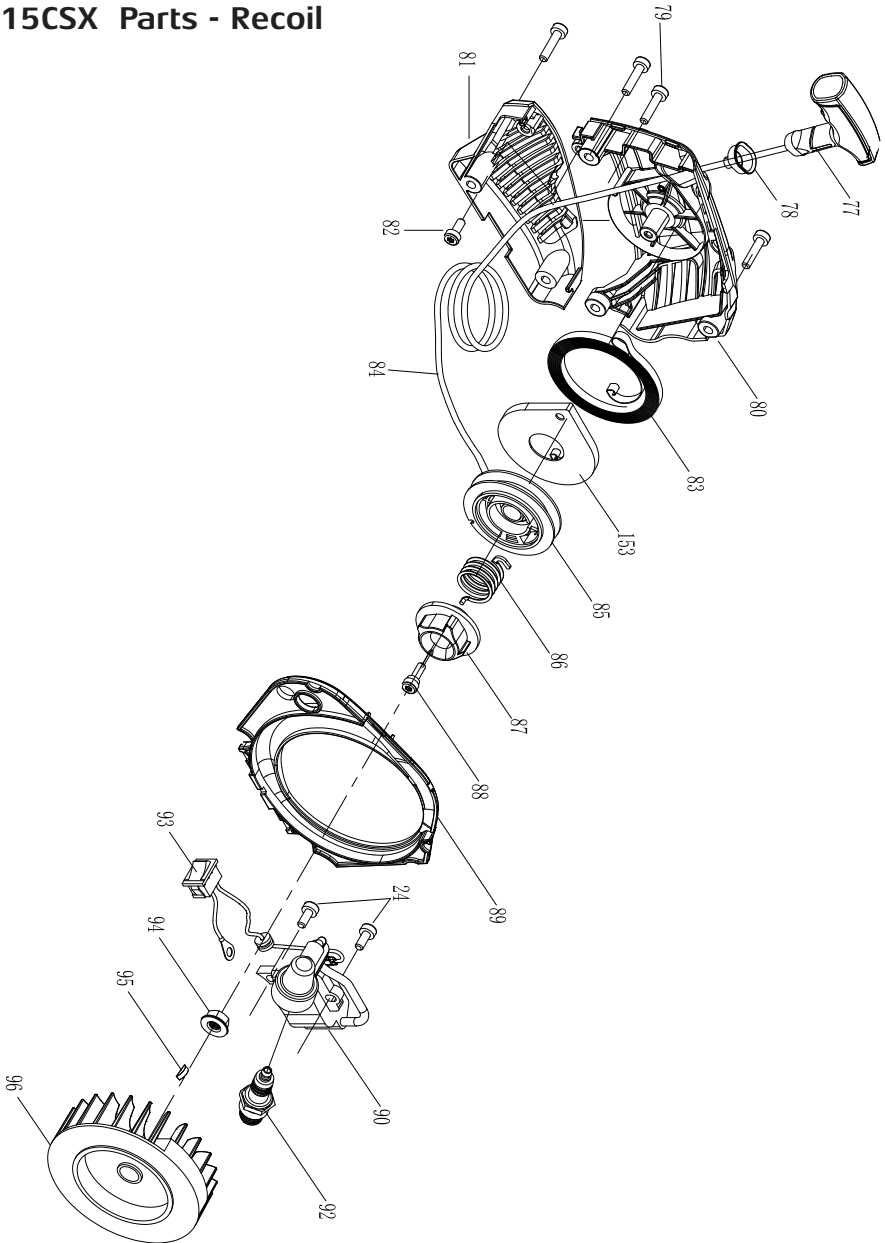

415CSX Parts - Recoil

NO.	PART NO.	DESCRIPTION	QTY
77	MIA41.1110.0003	STARTER HANDLE	1
78	MIA41.1110.0002	PROTECTION RING	1
79	MIA41.1100.0008	SCREW M5X25	4
80	MIA41.1110.0100-3	STARTER COVER - UPPER	1
81	MIA41.1110.0001-8	STARTER COVER - LOWER	1
82	MIA50.5100.0008	TAPPING SCREW ST4.8x13	2
83	MIA36.0110.0003	STARTER SPRING	1
84	MIA38.0310.0003	STARTER ROPE 3.0x920	1
85	MIA42.0110.0006	REEL	1
86	MIA42.0110.0008	STARTER TORSION SPRING	1
87	MIA42.0110.0007	STARTER RATCHET	1
88	MIA42.0110.0009	STARTER SCREW	1
89	MIA41.1100.0007	COVER	1
90	MIA42.0106.0200	IGNITION	1
92	MIA45.0106.0500	SPARK PLUG	1
93	MIA41.1106.0500-1	SWITCH	1
94	MI01.03.0073	NUT M8x1	1
95	MIA45.0101.0036	SEMI-CIRCLE KEY	1
96	MIA42.0106.0100	FLYWHEEL	1
153	MIA36.0110.0002	SPRING COVER	1

415CSX Parts - Brake Assembly

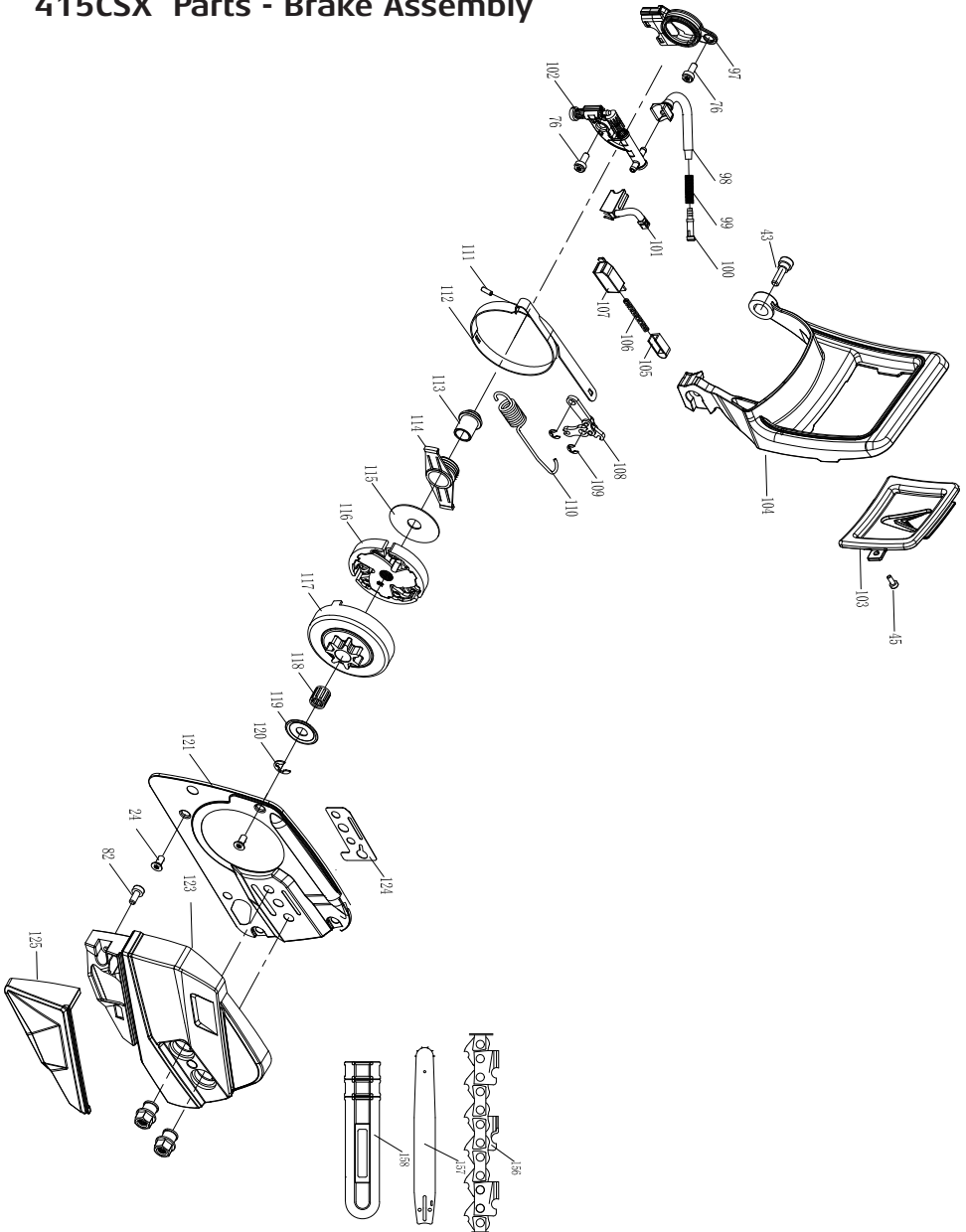

415CSX Parts - Brake Assembly

NO.	PART NO.	DESCRIPTION	QTY
97	MIA42.0114.0001-1	OIL PUMP COVER	1
98	MIA42.0114.0004	OIL TUBE	1
99	MIA42.0114.0003	OIL FILTER SPRING	1
100	MIA42.0114.0002-1	OIL FILTER	1
101	MIA42.0114.0005	SPRAY NOZZLE	1
102	MIA42.0114.0100	OIL PUMP	1
103	MIA41.1112.0002-5	INSERT	1
104	MIA41.1112.0300-4	CHAIN BRAKE LEVER	1
105	MIA42.0112.0013	RETURN SPRING FIXTURE	1
106	MIA42.0112.0011	RETURN SPRING	1
107	MIA42.0112.0012-1	RETURN SPRING COVER	1
108	MIA42.0112.0200	BRACKET	1
109	MI01.04.1041	E RING 5	2
110	MIA42.0112.0003	BRAKE SPRING	1
111	MI01.05.0231	POSITION PIN 3x8	1
112	MIA42.0112.0004	BRAKE BAND	1
113	MIA42.0101.0012	BUSH	1
114	MIA41.1101.0700-2	WORM	1
115	MIA42.0101.0011	WASHER	1
116	MIA42.0101.0500	CLUTCH	1
117	MIA42.0101.0015	SCREW M5x12	1
118	MIA42.0101.0600	NEEDLE BEARING 10x 14x13	1
119	MIA42.0101.0014	ANTI-FRICTION WASHER	1
120	MI06.03.160	E RING 8	1
121	MIA42.0112.0001	BRAKE SPRING COVER	1
123	MIA41.1112.0100-3	CLUTCH COVER	1
124	MIA42.1112.0014	COVER PLATE	1
125	MIA41.1112.0001-8	DISCHARGE COVER	1
156	MI07.04.1.06.301	OREGON SAW CHAIN 91P057X	1
157	MI07.04.1.04.303	OREGON GUIDE BAR 160SDEA041	1
158	MI07.04.1.10.321	GUIDE BAR COVER 16"	1

415CSX Parts - Fuel Tank Assembly

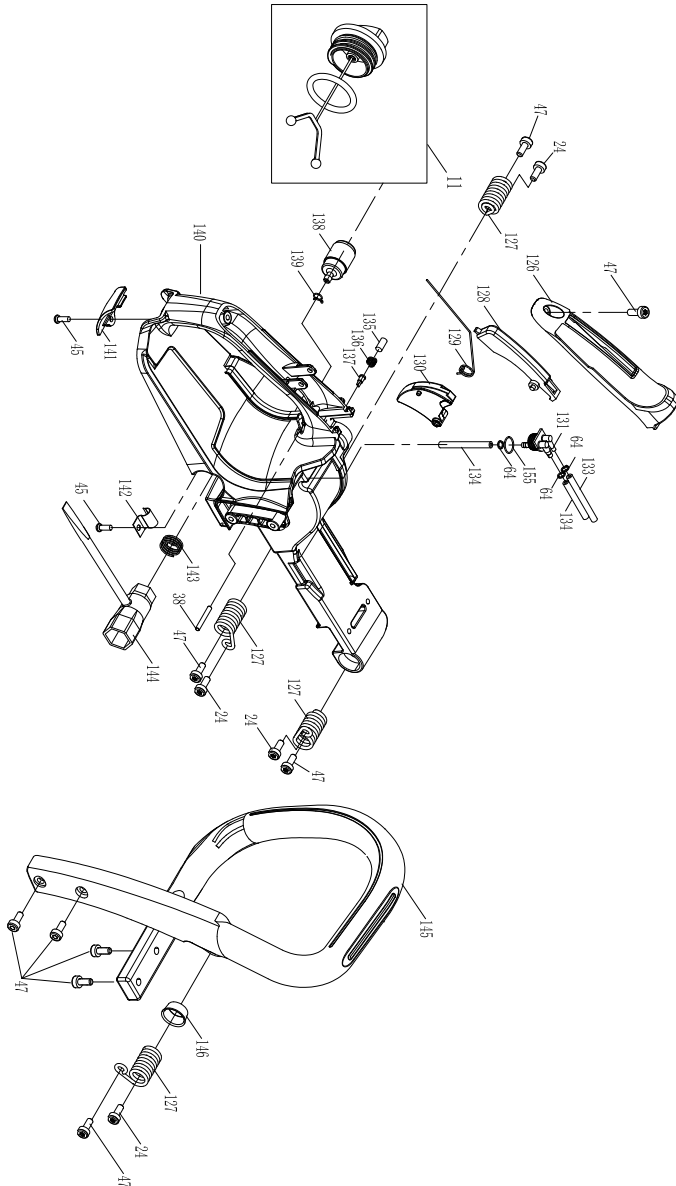

415CSX Parts - Fuel Tank Assembly

NO.	PART NO.	DESCRIPTION	QTY
126	MIA41.1111.0200-8	REAR HANDLE COVER	1
127	MIA42.0100.0004	ANTI-VIBRATION SPRING	4
128	MIA42.0111.0006-9	THROTTLE TRIGGER LOCK-OUT	1
129	MIA42.0111.0005	THROTTLE TRIGGER SPRING	1
130	MIA41.1111.0001-8	THROTTLE TRIGGER	1
131	MIA42.0111.0003	PIPE CONNECTION	1
133	MIA41.1111.0004	RETURN TUBE 2.5x 5x118	1
134	MIA42.0111.0002	FUEL PIPE 2.5x 5x93	2
135	MIA42.0111.0001	FILTER	1
136	MIA42.0111.0011	SPRING	1
137	MIA45.0102.0202	VENT VALVE	1
138	MI04.01.01.09808	FUEL FILTER	1
139	MIA42.1111.0010	CIRCLIP	1
140	MIA41.1111.0100-4	REAR HANDLE	1
141	MIA41.1111.0002-3	BOTTOM COVER	1
142	MIA41.1100.0014	STRAP SPRING	1
143	MIA41.1100.0013	FIXTURE SPRING	1
144	MIA41.1100.0012	SPARK PLUG WRENCH	1
145	MIA41.1100.0001	FRONT HANDLE	1
146	MIA42.0100.0003	SPRING BASE	1
155	MI03.01.2.170	O RING 10x1.5	1

EC Declaration of Conformity

The undersigned, as authorised by: **Mitox Garden Machinery**

Declares that the following equipment manufactured by Mitox conforms to the Directive: - 2000/14/EC of the European Parliament and of the council on the approximation of the laws of the Member States relating to the noise emission in the environment by equipment for use outdoors.

Equipment Category – Chainsaw for forest service with petrol engine

Product Name/Model: Mitox 415CSX

Type/Serial No.: As per rating label on machine

Cutting Width: 370mm

Net installed power: 41.4 cm³ / 1.85 kW

The technical documentation is kept by: Stewart Anderson, Rochford Garden Machinery Ltd., Murray Way, Wincanton Business Park, Somerset, BA9 9RS

The conformity assessment procedure followed was in according with annex EN ISO 11806-1:2011 of the Directive.

Notified Body: Interket Testing Services Shanghai, Building No. 86, 1198 Qinzhou Road (North), Shanghai 200233, China

Measured Sound Power Level: 99 dB

Guaranteed Sound Power Level: 114 dB

A copy of this certificate has been submitted to the European Commission and to EU Member State United Kingdom

Place of Declaration: China

Date: 01/07/2018

Signed by: S. Anderson
Position in Company: Managing Director

Signature: 



CONDITIONS OF WARRANTY

The manufacturer warrants the product against faulty materials and workmanship for a standard 1 year period and thereafter for the set period specific to each range from the date of purchase. Warranty does not extend to failure due to fair wear and tear.

SP	- 1 Year
SELECT	- 3 Years (Subject to yearly servicing)
PREMIUM	- 5 Years (Subject to yearly servicing)
PRO	- 5 Years Domestic / 3 Years Commercial (Subject to yearly servicing)

(Extended warranty is subject to online registration and yearly servicing)

SP, SELECT and PREMIUM ranges used for commercial purposes have a warranty period of 3 months from the date of purchase.

The manufacturer undertakes to replace any spare parts that are classified as defective by an appointed Mitox service dealer. The manufacturer will not accept liability for the replacement of the machine, either partially or wholly, and /or consequential damages and /or interest charges either directly or indirectly.

Warranty does not cover failure due to:

- Insufficient maintenance.
- Incorrect fuel mixture and stale fuel.
- Abnormal use or accidental damage.
- Incorrect assembly, adjustment or operation of the product.
- Spare parts that are subject to wear e.g. bag, blades, bearings, cables, guards, deflectors, spark plugs, air filters etc.

Neither does warranty extend to:

- Freight and packing costs.
- Use of non-genuine spare parts i.e. those from another manufacturer.
- Use of the machine for any other purpose than that for which it was designed.
- Use and maintenance of the machine in a manner not described in the owner's manual.

As part of our policy of continuous product improvement, we reserve the right to alter or amend this specification without notice. As a result, the product may differ from the information contained herein but any alteration will only be implemented without notice if it is classified as an improvement to the above specification.

READ THE MANUAL CAREFULLY BEFORE OPERATING THE MACHINE

When ordering spare parts, please quote the part number, this can be found in the parts list included in this manual.

Retain your proof of purchase, without which no warranty can be offered.

Mitox Garden Machinery, Wincanton Business Park, Wincanton, Somerset, BA9 9RS