



Operator's Manual

user manual, maintenance instructions and spare parts

41 LSH Electric Logsplitter

(Art No. MILS20)

Read this manual carefully before operating the machine
Original Instructions Version August 19



SAFETY WARNINGS & EXPLANATION OF SYMBOLS ON THE MACHINE

UNDERSTAND YOUR LOG SPLITTER

Read and understand the owner's manual and labels affixed to the log splitter. Learn its application and limitations as well as the specific potential hazards peculiar to it.



DRUGS, ALCOHOL AND MEDICATION

Do not operate the log splitter while under the influence of drugs, alcohol, or any medication that could affect your ability to use it properly.



AVOID DANGEROUS CONDITIONS

Always operate your log splitter on a 60 - 75cm high, stable, flat and level work bench, or on the optional work stand. Never operate your log splitter on slippery, wet, muddy, or icy surfaces. Keep your work area clean and well lit. Cluttered areas invite injuries. Do not use the log splitter in wet or damp areas or expose it to rain. Do not use it in areas where fumes from paint, solvents or flammable liquids pose a potential hazard.



INSPECT YOUR LOG SPLITTER

Check your log splitter before turning it on. Keep guards in place and in working order. Replace damaged, missing or failed parts before using it. Make sure all nuts, bolts, screws, hydraulic fittings, hose clamps, etc. are securely tightened. Always check the oil level in the hydraulic oil tank. Never operate your log splitter when it is in need of repair or is in poor mechanical condition.

WORK WEAR

Do not wear loose clothing, neckties or jewellery (rings, wrist watches). They can be caught in moving parts. Protective gloves and safety footwear are recommended when working. Wear protective hair covering to contain long hair, preventing it from getting caught in machinery.



PROTECT YOUR EYES AND FACE

Any log splitter may throw foreign objects into the eyes. This can cause permanent eye damage. Always wear safety goggles. Everyday eyeglasses have only impact resistant lenses. They are not safety glasses. **Do not put the log splitter on the ground for operations. This is an awkward operating position whereby the operator has to bring his face close to the machine, and thus risks being struck by wood chips or debris.**



EXTENSION CORDS

Only rubber cable complying with the H07RN-F quality standard stipulated in VDE 0282 Part 14 with a wire cross section of 2.5mm² should be used. The maximum permissible cable length is 10m. A longer cable may impair the motor performance and the function of the logsplitter. The connection cable, plug and socket should be free of damage. Repairs to the connection cable, plug and connection socket should only be carried out by a qualified electrician. A damaged connection cable should not be used. Plug connections should not be exposed to damp or water.

AVOID ELECTRICAL SHOCK

Check that the electric circuit is adequately protected and that it corresponds with the power and voltage of the motor. Check that there is a ground connection. Never open the switch / plug box. Should this be necessary, contact a qualified electrician. Make sure your fingers do not touch the plug's metal prongs when plugging or unplugging the log splitter.

PREVENT FIRES

Do not smoke or have open flames when operating or refilling the log splitter. Never operate the log splitter near a flame or spark. Oil is flammable and can be ignited.



KEEP BYSTANDERS AWAY

Allow only one person to load and operate the log splitter. Always keep bystanders, including visitors, children and pets away from the work area, especially when the log splitter is under operations. Only the operator should stand near the machine and only within the safe operating area of 5 metres. Never use another person to help you with freeing a jammed log. No one under the age of 16 should be allowed to operate the log splitter. Any individual under the age of 18 should have the necessary training and skills to perform the functions properly and safely and should always be under the supervision of an adult.



INSPECT YOUR LOG

Never attempt to split logs containing nails, wire or debris. Always make sure that both ends of the log you are splitting are cut as square as possible. This will prevent the log from sliding out of position while under pressure. Branches must be cut off flush with the trunk.

DON'T OVERREACH

Keep a proper footing and balance at all times. Never stand on the log splitter. Serious injury could occur if the tool is tipped or if the cutting tool is unintentionally contacted. Do not store anything above or near the log splitter where anyone might stand on the tool to reach it.

AVOID INJURY FROM UNEXPECTED ACCIDENT

Do not straddle or reach across the splitting area when operating the log splitter. Never pile logs to be split in a manner that will cause you to reach across the log splitter. Only use your hands to operate the control levers. Never use your foot, knee, a rope, or any other extension device. Always pay full attention to the movement of the wedge ram. Never attempt to load your log splitter while the ram is in motion. Keep hands out of the way of all moving parts. Never try to split two logs. One of them may fly up and hit you.



PROTECT YOUR HANDS

When the ram of the log splitter is in the return mode, keep your hands off the machine – the log splitter is designed to automatically stop when the cylinder is fully retracted. Keep your hands away from splits and cracks which open in the log. They may close suddenly and crush or injure your hands.

INCORRECT USE

Do not use the log splitter for a purpose for which it was not intended. Do not, under any circumstances, alter your log splitter. This equipment was designed and engineered to be used in accordance with the operating instructions. Altering the equipment, or using the equipment in such a way as to circumvent its design capabilities and capacities, could result in serious or fatal injury and will void the warranty. Never try to split logs larger than those indicated in the specifications table. This could be dangerous and may damage the machine.

NEVER LEAVE THE LOG SPLITTER RUNNING UNATTENDED

Don't leave the tool until it has come to a complete stop.

DISCONNECT POWER

Unplug the log splitter when not in use, before making adjustments, changing parts, cleaning or working on the log splitter. Consult your local Mitox dealer before servicing.



PROTECT THE ENVIRONMENT

Take used oil to an authorized collection point or follow the stipulations in the country where the log splitter is used. Do not discharge into drains, soil or water.

MAINTAIN YOUR LOG SPLITTER WITH CARE

Always clean the unit after each use. Keep the log splitter clean for best and safest performance. Follow instructions for lubricating. Inspect all hydraulic seals, hoses and couplers for leaks prior to use. Control levers and power switch must be kept clean, dry and free from oil and grease at all times.

MAKE THE WORKSHOP CHILDPROOF

Lock the workshop or garage. Store the log splitter away from children and others not qualified to use it.

FOR YOUR SAFETY

Do not remove or tamper with any of the machine's protection or safety devices or modify the log splitter in any way.

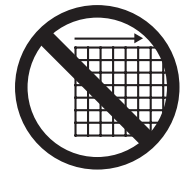

TABLE OF CONTENTS

Safety Warnings & Cautions2

Description of Product and Application Conditions.....5

Specifications.....5

Electrical Requirements5

Package Contents.....7

Log Splitter Operation13

Sharpening Wedge16

Replacing Hydraulic Oil17

Trouble Shooting19

Parts Schematic20

Declaration of Conformity23

DESCRIPTION OF MACHINE



**The log splitter is designed to be used in a domestic application.
The log splitter is designed exclusively for the following applications:**

-Splitting freshly cut timber that does not exceed the dimensions specified in the technical data.

APPLICATION CONDITIONS

This log splitter is designed to operate under ambient temperatures between +5°C and 40°C. It can be stored or transported under ambient temperatures between -25°C and 55°C.

SPECIFICATIONS

Model Number		41 LSH
Motor		1500W
Log Capacity	Diameter	50 ~ 250mm
	Length	370mm
Maximum Force		4 Ton
Hydraulic Pressure		2320 PSI
Hydraulic Oil Capacity		2.4 L
Overall Sizes	Length	995mm
	Width	425mm
	Height	610mm
Weight		45kg

* The diameter of the log is a guide - a small log can be difficult to split when it has knots or a particularly tough fibre. On the other hand, it may not be difficult to split logs with regular fibres even if their diameter exceeds the max. figure indicated above.

ELECTRICAL REQUIREMENTS

With a 230 Volt / 50Hz motor, the log splitter should be connected to a standard 230V+10% / 50Hz+1Hz. electrical supply as well as a residual current device (RCD) with the maximum residual current Rated at 0.03A.

PLEASE NOTE

The max splitting force can vary by +/- 10%

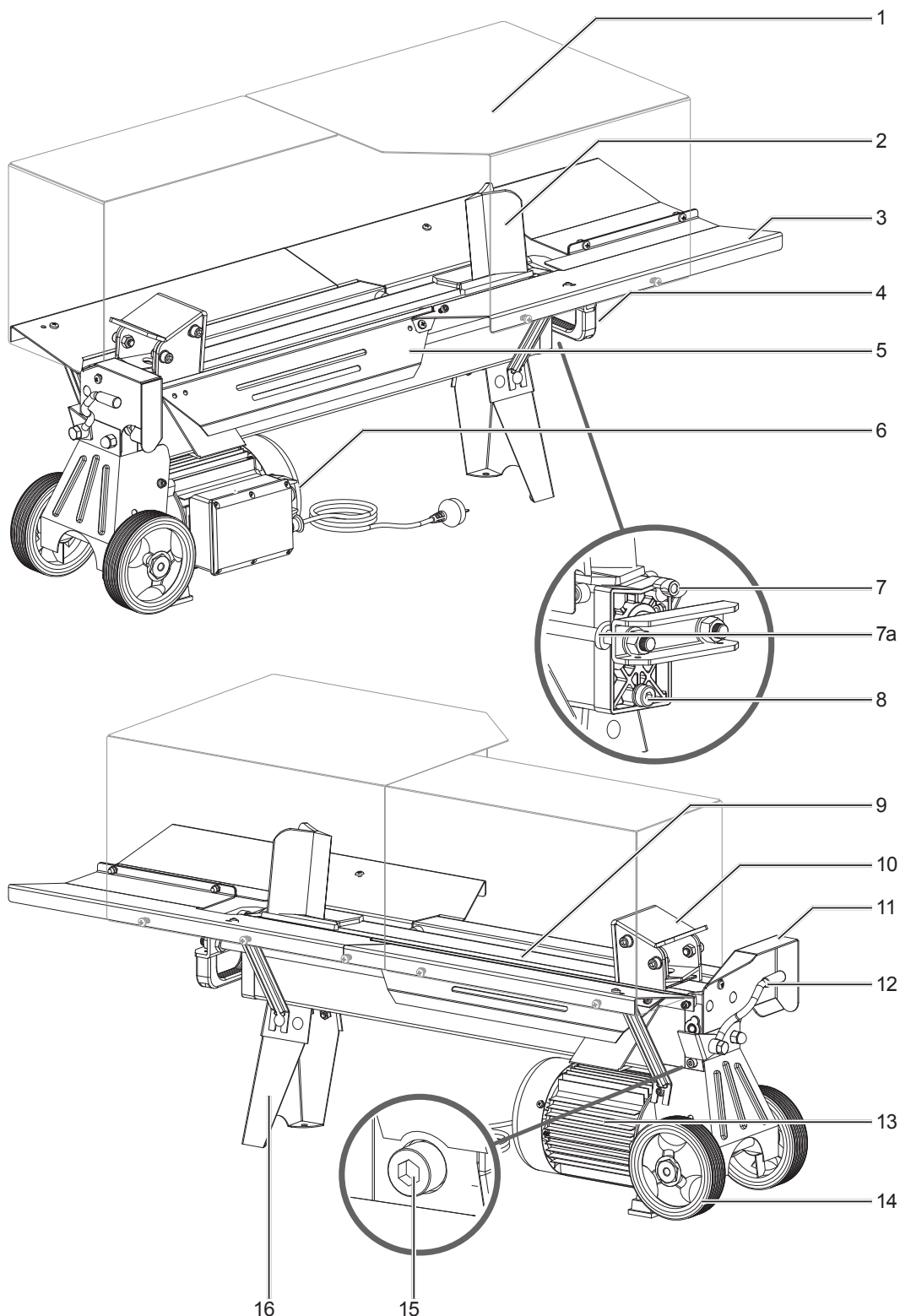

- | | |
|----------------------------------|------------------------------|
| 1. Guard | 9. Support surface |
| 2. Riving knife | 10. Pressure plate |
| 3. Tray table for split logs | 11. Control lever protection |
| 4. Handle | 12. Control lever |
| 5. Trunk guide plate | 13. Motor |
| 6. Triggering button | 14. Transport wheels |
| 7. Ventilation screw | 15. Pressure limiting screw |
| 8. Oil drain screw with dipstick | 16. Foot |

	M6 x 16	x 2	A
	M6 x 12	x 1	B
	M6 x 12	x 2	
	M6 x 12	x 1	C
	M6 x 12	x 1	
	M6 x 12	x 1	
	M6 x 12	x 1	D
	M6 x 12	x 1	
	M6 x 12	x 1	
	M6 x 12	x 2	E
	M6 x 20	x 19	f
	M6 x 20	x 1	

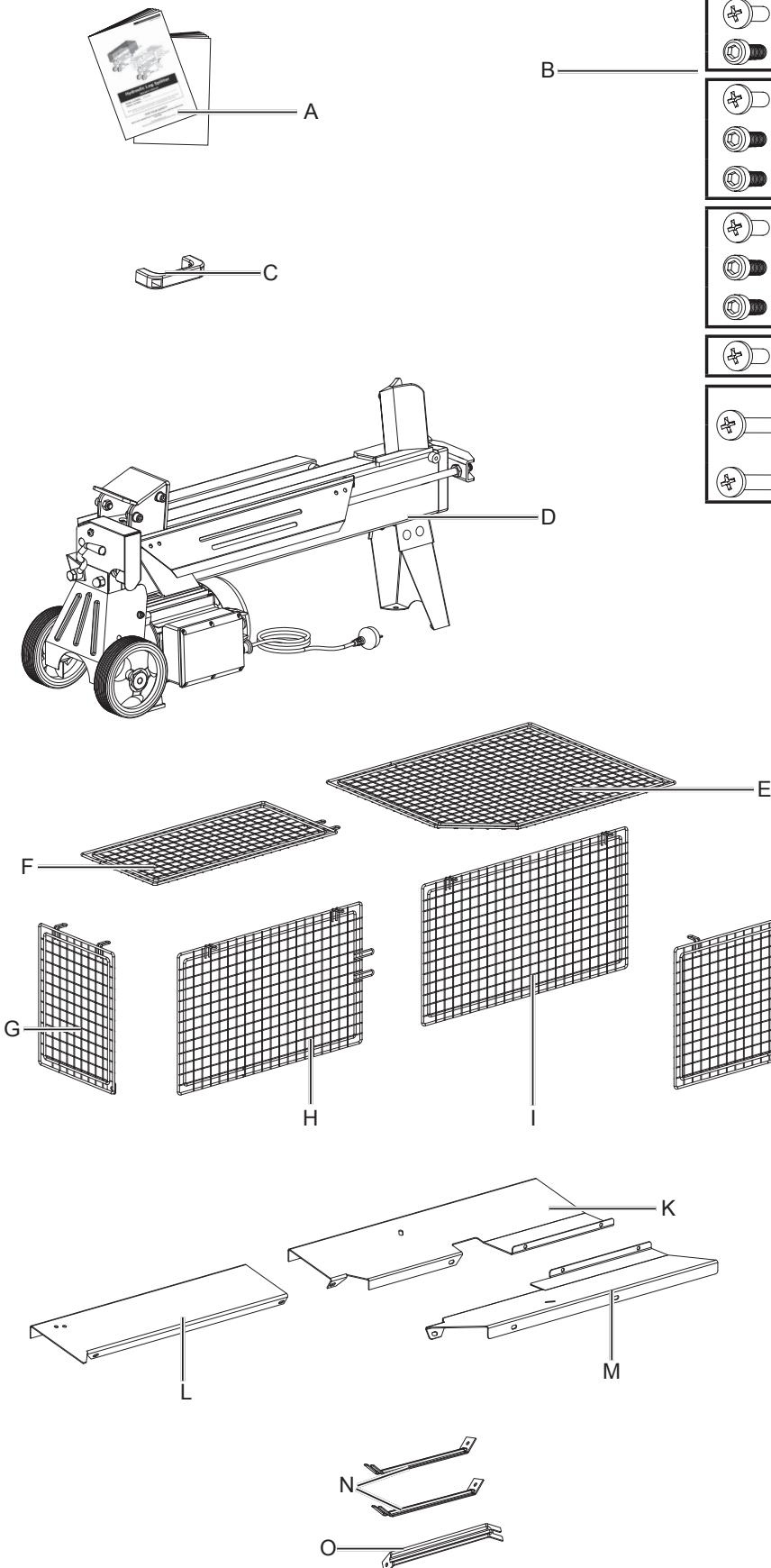

- A. Operating manual
- B. Enclosed accessories bag
(a, b, c, d, e, f)
- C. Handle
- D. Log splitter
- E. Top guard 1
- F. Top guard 2
- G. Left guard
- H. Rear guard 1
- I. Rear guard 2
- J. Front guard
- K. Tray table 1
- L. Protective guard
- M. Tray table 2
- N. Struts (2x)
- O. Strut

4. Intended use

The equipment is to be used only for its prescribed purpose. Any other use is deemed to be a case of misuse. The user / operator and not the manufacturer will be liable for any damage or injuries of any kind caused as a result of this.

To use the equipment properly you must also observe the safety information, the assembly instructions and the operating instructions to be found in this manual.

All persons who use and service the equipment have to be acquainted with this manual and must be informed about the equipment's potential hazards.

It is also imperative to observe the accident prevention regulations in force in your area. The same applies for the general rules of health and safety at work.

The manufacturer will not be liable for any changes made to the equipment nor for any damage resulting from such changes.

- The hydraulic log splitter is only suitable for horizontal operation. Wood may only be split while horizontal and in the direction of the grain. Dimensions of wood to be split: maximal 37 cm.
- Never split wood against the grain or while in an upright position.
- The manufacturer's safety, operation and maintenance instructions as well as the technical data given in the calibrations and dimensions must be adhered to.
- Relevant accident prevention regulations and other generally recognized safety and technical rules must also be adhered to.
- The machine may only be used, maintained or repaired by trained persons who are familiar with the machine and have been informed about the dangers. Unauthorized modifications of the machine exclude a liability of the manufacturer for damages resulting from the modifications.
- Any other use is considered to be not intended. The manufacturer excludes any liability for resulting damages, the risk is exclusively borne by the user.
- Keep work area clean and free of obstacles.
- Operate the unit only on a flat and firm surface.
- Check the proper function of the splitter before each start-up.
- Operate only in areas with a maximum altitude of 1000 m above sea level.

Please note that our equipment has not been designed for use in commercial, trade or industrial applications. Our warranty will be voided if the equipment is used in commercial, trade or industrial businesses or for equivalent purposes.

5. Safety notes



WARNING: When you use electric machines, always observe the following safety instructions in order to reduce the risk of fire, electric shock, and injuries.

Please read all the instructions before you work with this machine.

- Observe all safety notes and warnings attached to the machine.
- See to it that safety instructions and warnings attached to the machine are always complete and perfectly legible.
- Protection and safety devices on the machine may not be removed or made useless.
- Check electrical connection leads. Do not use any faulty connection leads.
- Before putting into operation check the correct function of the two-hand control.

- Operating personnel must be at least 18 years of age. Trainees must be at least 16 years of age, but may only operate the machine under adult supervision.
- Children may not work with this device
- Wear work and safety gloves, safety goggles, close-fitting work clothes, and hearing protection (PPE) while working.
- Caution when working: There is a danger to fingers and hands from the splitting tool.
- Before starting any conversion, setting, cleaning, maintenance or repair work, always switch off the machine and disconnect the plug from the power supply.
- Connections, repairs, or servicing work on the electrical equipment may only be carried out by an electrician.
- All protection and safety devices must be replaced after completing repair and maintenance procedures.
- When leaving the work place, switch off the machine and disconnect the plug from the power supply.
- **Removing or working without guards is prohibited.**
- When splitting, the properties of the wood (e.g. growths, trunk slices of irregular shape, etc.) can result in hazards such as ejecting parts, splitter blocking, and crushing.

6. Additional safety instructions

- The log splitter may only be operated by one person.
- Never split logs containing nails, wire, or other foreign objects.
- Already split wood and wood chips can be dangerous. You can stumble, slip or fall down. Keep the working area tidy.
- While the machine is switched on, never put your hands on moving parts of the machine.
- Only split logs with a maximum length of cm.



Warning! This electric tool generates an electromagnetic field during operation. This field can impair active or passive medical implants under certain conditions. In order to prevent the risk of serious or deadly injuries, we recommend that persons with medical implants consult with their physician and the manufacturer of the medical implant prior to operating the electric tool.

Remaining hazards

The machine has been built using modern technology in accordance with recognized safety rules. Some remaining hazards, however, may still exist.

- The splitting tool can cause injuries to fingers and hands if the wood is incorrectly guided or supported.
- Thrown pieces can lead to injury if the work piece is not correctly placed or held.
- Injury through electric current if incorrect electric connection leads are used.
- Even when all safety measures are taken, some remaining hazards which are not yet evident may still be present.
- Remaining hazards can be minimized by following the safety instructions as well as the instructions in the chapter Authorized use and in the entire operating manual.
- Health hazard due to electrical power, with the use of improper electrical connection cables.
- Release the handle button and switch off the machine prior to any operations.

- Avoid accidental starts of the machine: Do not press the start button while inserting the plug into the socket.
- Use the tools recommended in this manual to obtain the best results from your machine.
- Always keep hands away from the work area when the machine is running.

Noise

 **WARNING:** Noise can have serious effects on your health. If the machine noise exceeds 85 dB (A), please wear suitable hearing protection.

8. Unpacking

Open the packaging and remove the device carefully.

Remove the packaging material as well as the packaging and transport bracing.

Check that the delivery is complete.

Check the device and accessory parts for transport damage.

In case of complaints the dealer must be informed immediately. Subsequent complaints will not be accepted.

If possible, store the packaging until the warranty period has expired.

Read the operating manual to make yourself familiar with the device prior to using it.

Only use original parts for accessories as well as for wearing and spare parts. Spare parts are available from your specialized dealer.

Specify our part numbers as well as the type and year of construction of the device in your orders.



ATTENTION

The device and packaging materials are not toys!

Children must not be allowed to play with plastic bags, film and small parts! There is a risk of swallowing and suffocation!

9. Assembly

At least two people are required to assemble the device.

9.1 Installing the handle (4) (enclosed accessories bag a)

Fasten the handle to the U-bar with two cylindrical screws.

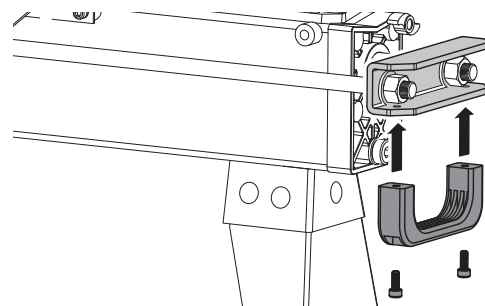

9.2 Installing the protective guard (L) (enclosed accessories bag b)

1. Fit the protective guard (L) to the trunk guide plate (5) and use the enclosed cylindrical screws and nuts to affix it.

2. Undo the cylindrical screw with washer that is located on the wheel bracket.

3. Fasten the other end of the strut to the protective guard using the Phillips head screw and nut. (3)

4. Now guide the open end of the strut (O) between the washer and the wheel bracket, tighten the cylindrical screw (4) again firmly.

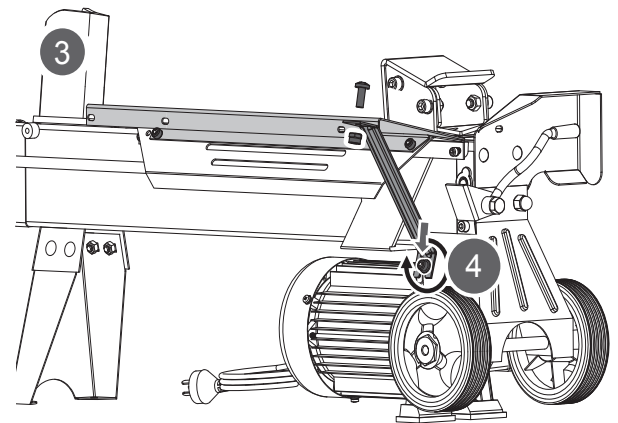
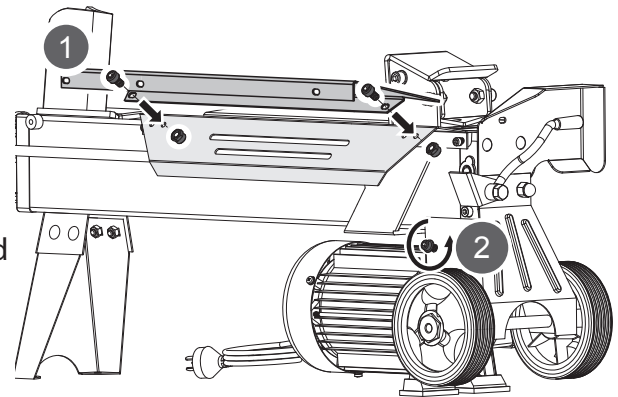

9.3 Installing the tray table (K + M) (enclosed accessories bag c + d + e)

1. Attach the tray table (K) to the same side as the protective guard (L). Use two cylindrical screws and spring washers to affix the table to the log splitter. (1)

2. Ensure that the table and the protective guard are level in relation to each other.

3. Undo the screw on the left of the foot.

4. Fasten the other end of the strut to the protective guard using the Phillips head screw and nut, align everything and tighten the screws firmly.

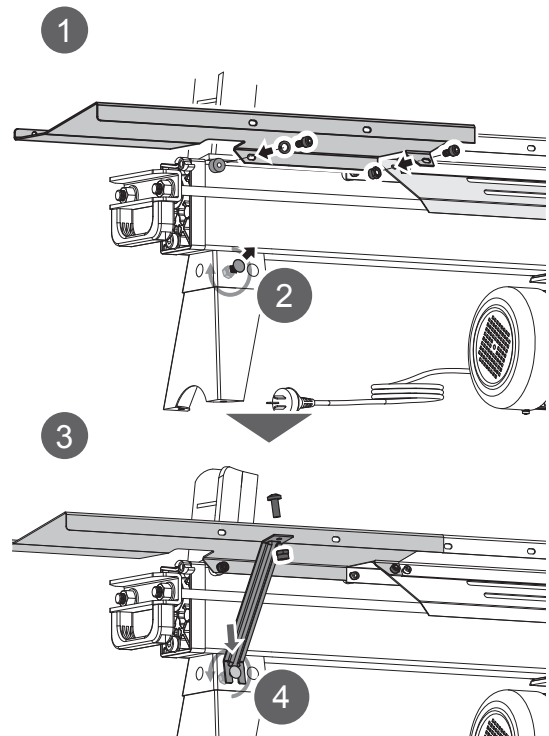

5. Now guide the open end of the strut (N) between the screw and the foot bracket, tighten the screw slightly.

6. Repeat the process on the other side.

7. Align both tables in relation to each other and use the Phillips head screws and nuts (e) to affix them.

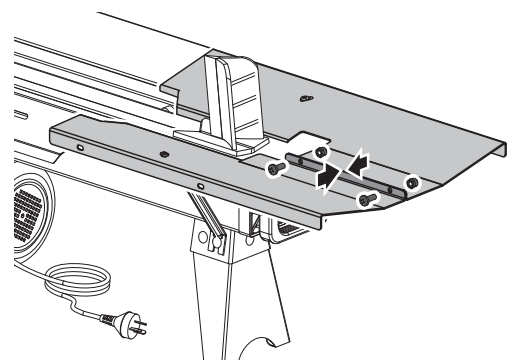
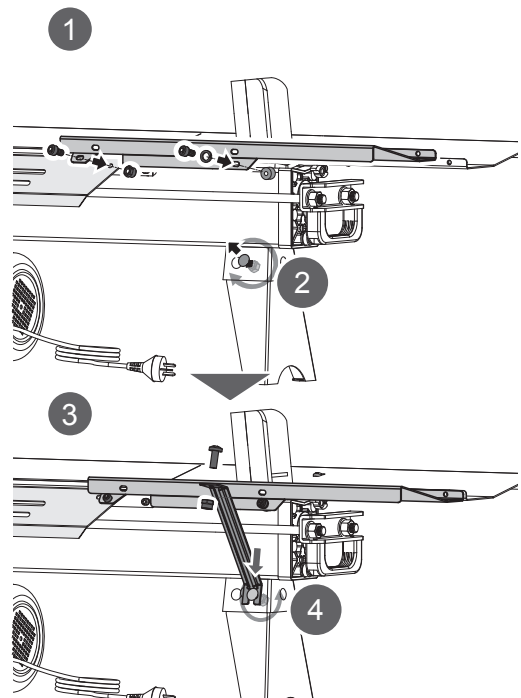

9.4 Installing the guard (E - J) (enclosed accessories bag f)

1. Connect the guards (H) and (I) together, use two Phillips head screws, clamping brackets and nuts to affix it.

2. Fasten the guards (H, I, J) to the holes provided for this. These are on the side of the table and the protective guard. Fasten the guard with seven Phillips head screws, clamping brackets and nuts. Fit the protective guard (G) to the control lever protection (11) and use a Phillips head screw and a nut to affix it.

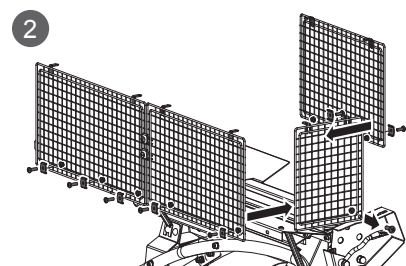
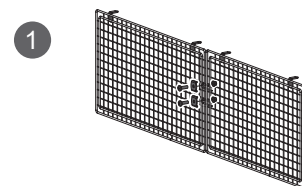

3. Now fasten the guards (E + F) on the top. Fasten them with eight Phillips head screws, clamping brackets and nuts.

4. Fasten the guards (E + F) together using two Phillips head screws, clamping brackets and nuts.



IMPORTANT!

You must fully assemble the appliance before using it for the first time!

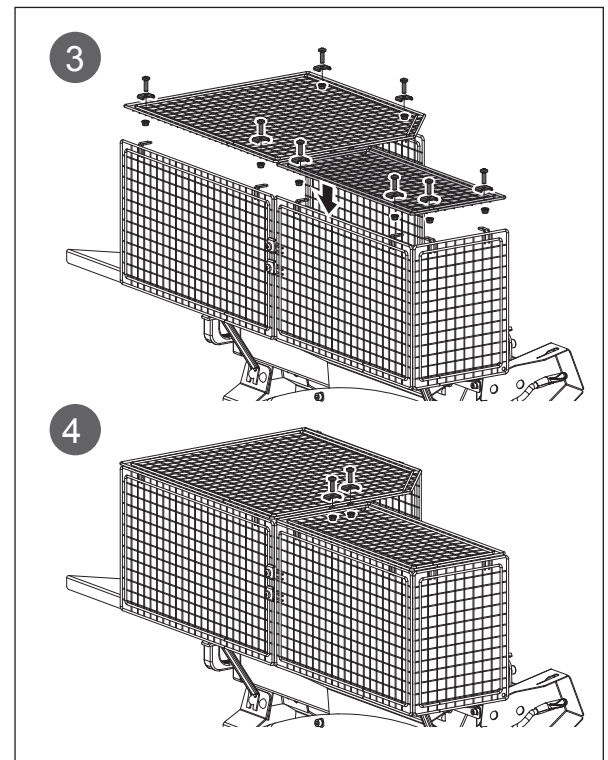

10. Initial operation

Before start-up, place the splitter on a stable, level and flat workbench so that the splitter tray table sits at a height of 72 - 85 cm. If the machine should slip during splitting work, fasten it to the table with two screws (M8 x X = thickness of the table). To do so, use the two holes on the foot (16).

Make sure the machine is completely and expertly assembled. Check before every use:

- the connection cables for any defective spots (cracks, cuts etc.).
- the machine for any possible damage.
- the firm seat of all bolts.
- the hydraulic system for leakage.
- the oil level and
- the safety devices

10.1 Checking the oil level (Fig. 15)

The hydraulic unit is a closed system with oil tank, oil pump and control valve. Check the oil level regularly before every use. Too low an oil level can damage the oil pump. If the oil level is at the lower notch, then the oil level is at a minimum. Should this be the case, oil must be immediately added. The upper notch indicates the maximum oil level. The machine must be on level ground. Screw in the oil dipstick fully, to measure the oil level.

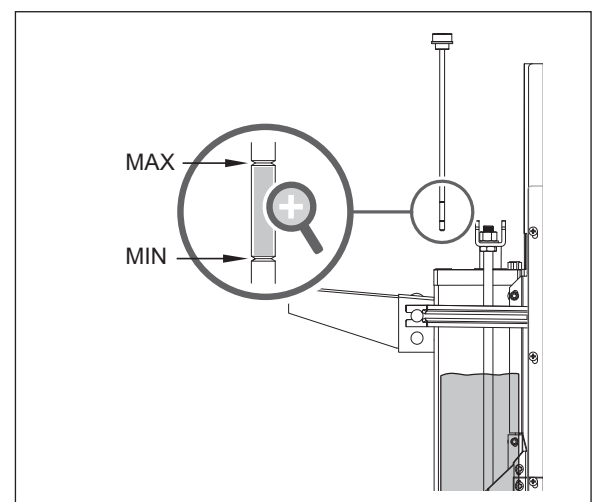

10.2 Ventilation screw

Before operating your machine, the bleed screw (7) should be loosened by some rotations until air can go in and out of the oil tank smoothly. Failed to loosen the bleed screw will keep the sealed air in hydraulic system being compressed after being decompressed. Such continuous compression/decompression will blow out the seals of the hydraulic system and cause permanent damage to your machine. Before moving your machine, make sure the bleed screw is tightened to avoid oil leaking from this point.

10.3 Splitting logs

Only split logs that have been sawn off straight. To do this, proceed as follows:

1. Place the log plain onto the work table (9).
2. Your machine is equipped with Two-hands Control System that requires to be operated by both hands of the user – left hand controls the control lever (12) while right hand controls the push button switch (6).
3. Simultaneously push button switch (6) to start the splitting action.

The log splitter will freeze upon absence of either hand.

Never force your machine for more than 5 seconds by keeping pressure on it to split excessively hard wood.

After this time interval, the oil under pressure will be overheated and the machine could be damaged.

For such extremely hard log, rotate it by 90° to see whether it can be split in a different direction. In any case, if you are not able to split the log, this means that its hardness exceeds the capacity of the machine and thus should be discarded to protect the log splitter.

10.4 Hoist limiting

It is reasonable to limit the hoist of the pressure plate (10) for short splitting material. Thereto press the control lever (12) and the release button (6) and let the pressure plate (10) move just in front of the splitting material.

Release the release button now and mount the hoist limiting ring (7a) to the housing and tighten it.

Afterwards you can release the hydraulics lever.

The pressure plate will now be resting in the selected position.

10.5 Wrongly placed log

Always set logs firmly on the log retaining plates and work table. Make sure logs will not twist, rock or slip while being split. Do not force the blade by splitting logs on the upper part. This will break the blade or damage the machine.

Do not attempt to split 2 pieces of logs at the same time. One of them may fly up and hit you.

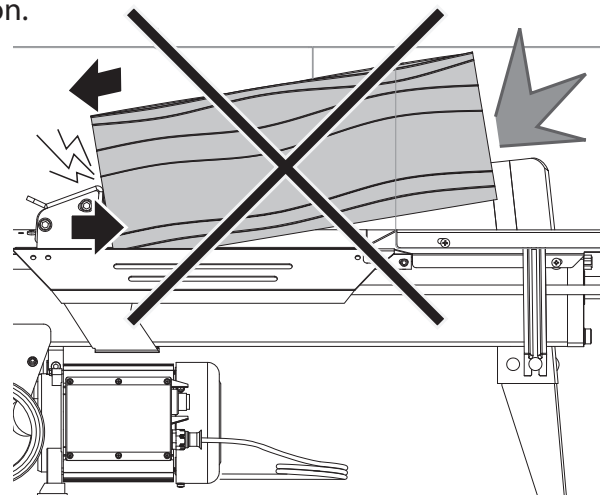

10.6 Jammed log

Do not try to knock the jammed log off. Knocking about will damage the machine or may launch the log and cause accident.

1. Release both controls.
2. After the log pusher moves back and completely stops at its starting position, insert a wedge wood under the jammed log (see figure 15).
3. Start the log splitter to push the wedge wood under the jammed one.
4. Repeat above procedure with sharper sloped wedge woods until the log is completely freed.

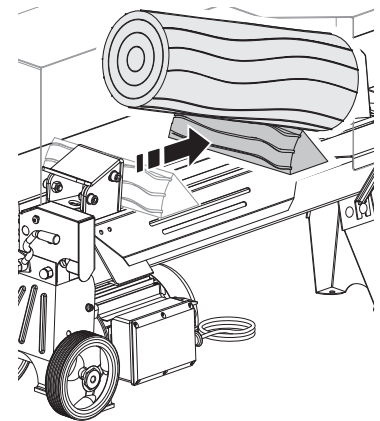
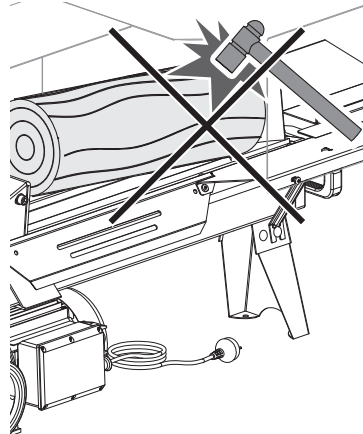

11. Electrical connection

The electrical motor installed is connected and ready for operation. The connection complies with the applicable VDE and DIN provisions.

The customer's mains connection as well as the extension cable used must also comply with these regulations.

Damaged electrical connection cable

The insulation on electrical connection cables is often damaged.

This may have the following causes:

- Passage points, where connection cables are passed through windows or doors.
- Kinks where the connection cable has been improperly fastened or routed.
- Places where the connection cables have been cut due to being driven over.
- Insulation damage due to being ripped out of the wall outlet.
- Cracks due to the insulation ageing.

Such damaged electrical connection cables must not be used and are life-threatening due to the insulation damage.

Check the electrical connection cables for damage regularly. Make sure that the connection cable does not hang on the power network during the inspection. Electrical connection cables must comply with the

applicable VDE and DIN provisions. Only use connection cables with the marking „H07RN“.

The printing of the type designation on the connection cable is mandatory.

For single-phase AC motors, we recommend a fuse rating of 16A (C) or 16A (K) for machines with a high starting current (starting from 3000 watts)!

AC motor 230 V/ 50 Hz

Mains voltage 230 Volt / 50 Hz.

- The mains connection and the extension cable have to be three-core cables = P + N + SL. - (1/N/ PE).
- Extension cables must have a minimum cross-section of 1.5 mm².
- Mains fuse protection is 16 A maximum.

12. Cleaning



ATTENTION!

Pull out the power plug before carrying out any cleaning work on the equipment.

We recommend that you clean the equipment immediately after you use it.

Clean the equipment regularly with a damp cloth and some soft soap. Do not use cleaning agents or solvents; these may be aggressive to the plastic parts in the equipment. Ensure that no water can get into the interior of the equipment.

13. Transport

The log splitter is equipped with two wheels for easy transport. The machine can be transported on the wheels at an angle. Use the transport handle, lift and pull or push.

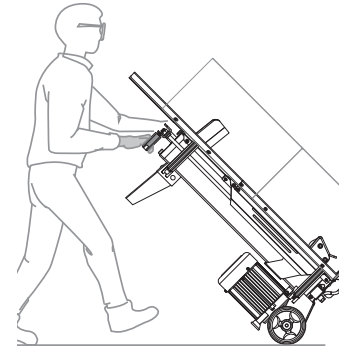

14. Storage

Store the device and its accessories in a dark, dry and frost-proof place that is inaccessible to children. The optimum storage temperature is between 5 and 30°C. Cover the electrical tool in order to protect it from dust and moisture. Store the operating manual with the electrical tool.

15. Maintenance



ATTENTION!

Pull out the power plug before carrying out any maintenance work on the equipment.

We recommend:

- The splitting wedge is a wearing part that needs to be sharpened or replaced after wear.
- The combined gripping and controlling device must remain smooth running. Lubricate with a few drops of oil when necessary.
- Keep splitting wedge drive clean of dirt, wood shavings, bark, etc.
- Lubricate slide rails with grease.

When must the oil be changed?

Change the oil after 150 working hours.

Oil change.

1. Move the log splitter into the start position and pull out the mains plug.

2. Undo the oil drain screw with dipstick (8) and put it to one side.

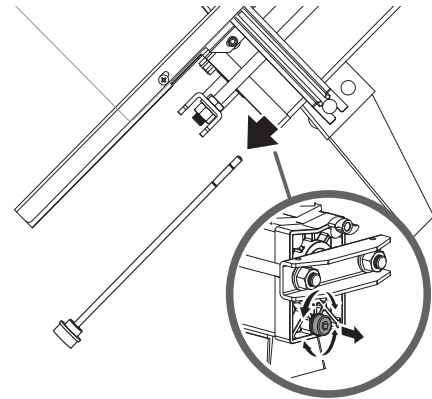

3. Turn the log splitter on the support leg side as shown in fig. 17 over a 4 litre capacity container to drain the hydraulic oil off. Recycle carefully! Dispose of the waste oil in an environmentally friendly manner!

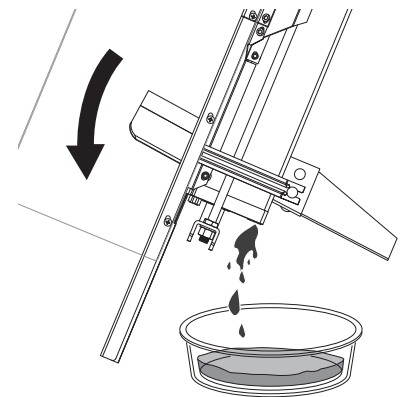

4. Turn your machine on the motor side as shown to refill about 2.4 l fresh oil.

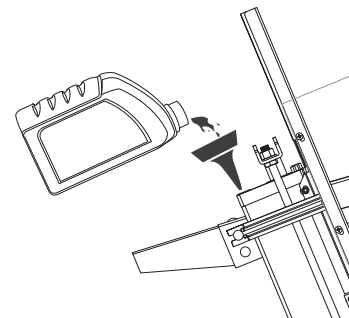

5. Clean the oil drain screw with dipstick (8) and screw it back in to the machine that is still in a vertical position. Unscrew it again; there should be an oil film between the two notches.

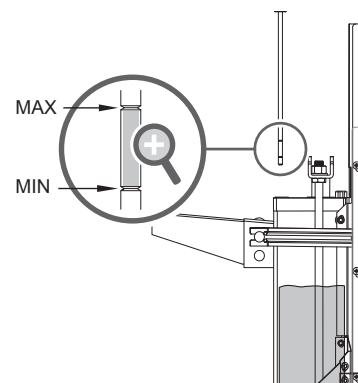

6. Now screw the oil drain screw with dipstick back in tightly. Afterwards start splitting without actually splitting log several times.

7. Check the oil level one last time and top up with a little oil if required.

Dispose of the used oil in a correct manner at a public collection facility. It is prohibited to drop old oil on the ground or to mix it with waste.

We recommend oil from the HLP 32 range.

Connections and repairs

Connections and repairs of electrical equipment may only be carried out by an electrician.

Please provide the following information in the event of any enquiries:

- Type of current for the motor
- Machine data - type plate
- Machine data - type plate

Service information

Please note that the following parts of this product are subject to normal or natural wear and that the following parts are therefore also required for use as consumables.

Wear parts*: splitting wedge guides, hydraulic oil, splitting wedge

* Not necessarily included in the scope of delivery!

16. Disposal and recycling

The equipment is supplied in packaging to prevent it from being damaged in transit. The raw materials in this packaging can be reused or recycled. The equipment and its accessories are made of various types of material, such as metal and plastic. Defective components must be disposed of as special waste. Ask your dealer or your local council.

Old devices must not be disposed of with household waste!



This symbol indicates that this product must not be disposed of together with domestic waste in compliance with the Directive (2012/19/EU) pertaining to waste electrical and electronic equipment (WEEE). This product must be disposed of at a designated collection point. This can occur, for example, by handing it in at an authorised collecting point for the recycling of waste electrical and electronic equipment. Improper handling of waste equipment may have negative consequences for the environment and human health due to potentially hazardous substances that are often contained in electrical and electronic equipment. By properly disposing of this product, you are also contributing to the effective use of natural resources.

You can obtain information on collection points for waste equipment from your municipal administration, public waste disposal authority, an authorised body for the disposal of waste electrical and electronic equipment or your waste disposal company.

17. Troubleshooting

The table below contains a list of error symptoms and explains what you can do to solve the problem if your tool fails to work properly. If the problem persists after working through the list, please contact your nearest service workshop.

PROBLEM	PROBABLE CAUSE	REMEDY SUGGESTED
Motor stops starting	Overload protection device disengaged to protect the log splitter from being damaged	Contact a qualified Electrician.
Fails to split logs	Log is improperly positioned	Refer to "Log Splitter Operation" section for perfect log loading
	The size or hardness of the log exceeds the capacity of the machine	Reduce the log size before splitting it on the log splitter
	Wedge cutting edge is blunt	Refer to "Sharpening Wedge" section to sharpen the cutting edge
	Oil leaks	Locate leak(s) and contact the dealer
The log pusher moves jerkily, making unfamiliar noises or vibrating a lot.	Lack of hydraulic oil and excessive air in the hydraulic system	Check oil level for possible oil refilling. Contact the dealer
Oil leaks around cylinder ram or from other points.	Air sealed in hydraulic system while operating	Loosen Bleed Screw by 3-4 rotations before operating the log splitter
	Bleed Screw is not tightened before moving the log splitter	Tighten the Bleed Screw up before moving the log splitter
	Oil Drain Bolt with Dipstick is not tight	Tighten the Oil Drain Bolt with Dipstick
	Hydraulic Control Valve Assembly and / or seal(s) worn	Contact your dealer

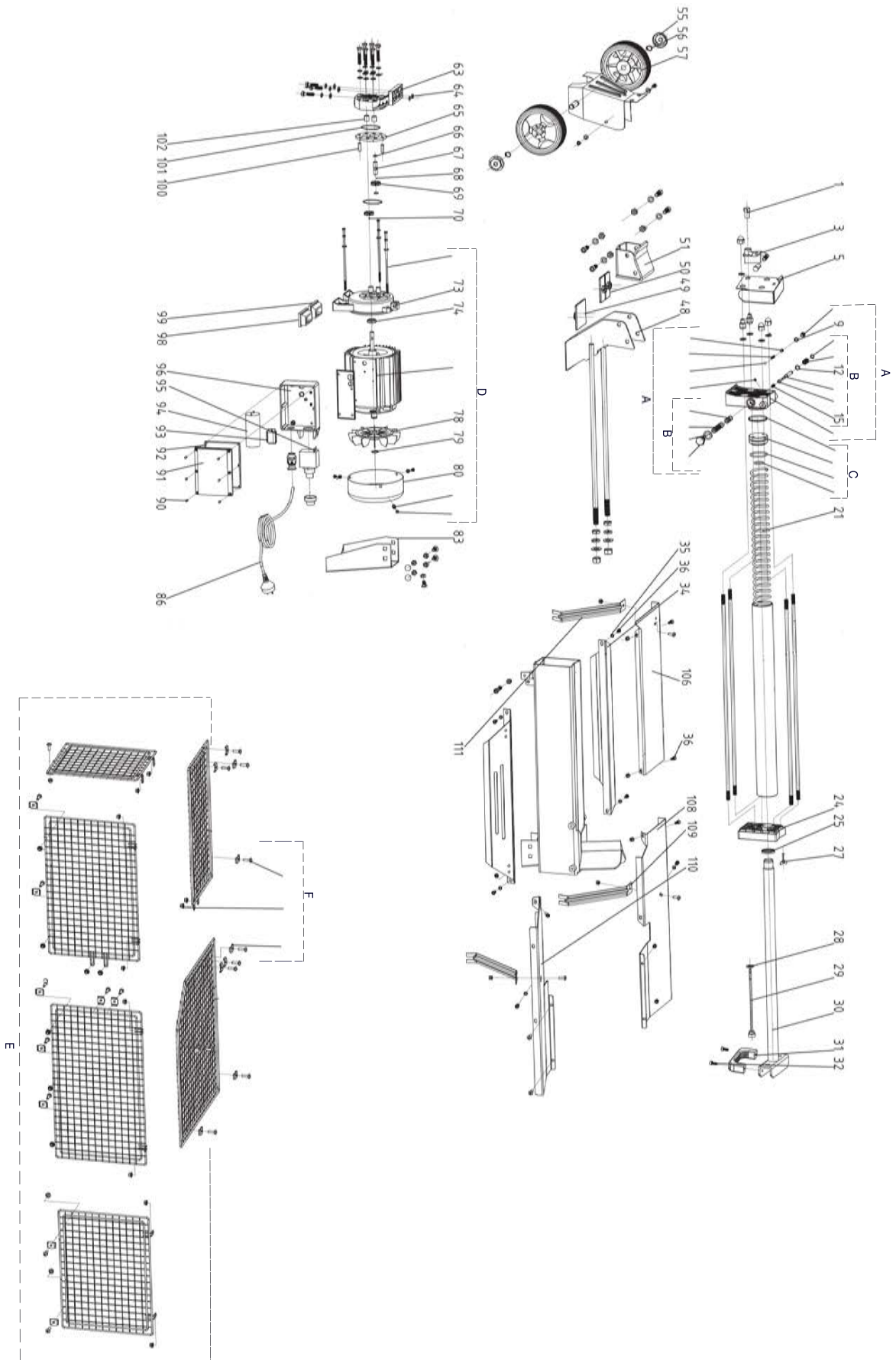

ID	PART No	DESCRIPTION
1	MI3905201026	NUT - (LEVER)
3	MI3905201027	LEVER
5	MI3905201073	GUARD
A	MI3905201057	HOUSING WITH CONTROL VALVE
9	MI5905206013	O-RING
B	MI3905201028	CONTROL VALVE ASSEMBLY
12	MI5905206014	O-RING
15	MI5905206016	SPRING
C	MI3905201023	PISTON SET
24	MI3905201029	OIL CAP
25	MI3905202142	SEAL
27	MI16040394	BLEED SCREW
28	MI3905201030	WASHER
29	MI5905201004	DIPSTICK
30	MI5905201003	PISTON ROD
31	MI3905201031	LIFT HANDLE
32	MI02091238	SCREW M6X25
34	MI3905201032	PLATE
35	MI02012705	SPRING WASHER
36	MI02091235	SCREW M6X12
48	MI3905201055	CARRIER
49	MI3905202012	PLASTIC INSERT - LOWER
50	MI3905202013	PLASTIC INSERT - UPPER
51	MI3905201035	LOG PUSHER
55	MI3905202014	WHEEL CAP
56	MI01047111	CIRCLIP
57	MI3905201036	WHEEL
63	MI3905201037	GEAR PUMP COVER
64	MI3905202052	O-RING
65	MI5905206003	GEAR HOUSING PLATE
66	MI5905206004	CIRCLIP
67	MI5905206005	GEAR SHAFT
68	MI5905206006	STEEL BALL
69	MI3905202143	GEAR
70	MI5905206007	PIN
73	MI3905201058	MOTOR COVER
74	MI16040602	SEAL
D	MI3905201038	MOTOR ASSEMBLY
78	MI3905201039	FAN
79	MI01047113	CIRCLIP

ID	PART No	DESCRIPTION
80	MI3905201040	MOTOR HOOD
83	MI3905201044	FOOT
86	MI5905206012	CABLE WITH PLUG
90	MI02798114	SCREW
91	MI5905211001	SWITCH BOX COVER
92	MI3905201042	SEAL
93	MI3905201043	CLAMP
94	MI52017101	CAPACITOR 25UF
94	MI16040424	CAPACITOR 30UF
95	MI3905201046	SWITCH
96	MI5905211002	SWITCH BOX COVER
98	MI3905201048	RUBBER FOOT L/H
99	MI3905201049	RUBBER FOOT R/H
100	MI5905206010	PIN
101	MI3905202141	GASKET
102	MI16040886	BUSHING
106	MI5905209001	PLATE - LHF
108	MI5905209002	PLATE - LHB
109	MI5905211005	STRUT - LONG
110	MI5905209003	PLATE - RHB
111	MI5905211007	STRUT - SHORT
E	MI5905209004	CAGE SET
F	MI5905211009	FITTING FOR CAGE SET

EC Declaration of Conformity

We herewith declare

that the following machine complies with the appropriate basic safety and health requirements of the EC Directive based on its design and type, as brought into circulation by us.

In case of alteration of the machine, not agreed by us, this declaration will lose its validity.

Description : Log Splitter
Type: 65553 (MITOX 41 LSH)
Test report No. AM 50414808 0001 / 17703106 029

Applicable EC Directives : EC Directive of Machinery (2006/42/EC)
EC Directive of Electromagnetic
Compatibility (2014/30/EU)

Applicable Harmonized Standards: EN 55014-1:2017
EN55014-2:2015
EN 61000-3-2:2014
EN 61000-3-11:2000
EN 60204-1:2006+A1:2009+AC:2010
EN 609-1:2017

Name of Company: TIYA International Co., Ltd.
Address: B12B, Shenye Center, 9 Shandong Road,
Qingdao, China
Tel: (532) 8582 3333
Fax: (532) 8582 4444
Name / Title: Yuan Yue/ Director

Singature:



Place / Date: Qingdao, China / 30/08/18

CONDITIONS OF WARRANTY

The manufacturer warrants the product against faulty materials and workmanship for a standard 1 year period and thereafter for the set period specific to each range from the date of purchase. Warranty does not extend to failure due to fair wear and tear.

SP	- 1 Year
SELECT	- 3 Years (Subject to yearly servicing)
PREMIUM	- 5 Years (Subject to yearly servicing)
PRO	- 5 Years Domestic / 3 Years Commercial (Subject to yearly servicing)

(Extended warranty is subject to online registration and yearly servicing)

SP, SELECT and PREMIUM ranges used for commercial purposes have a warranty period of 3 months from the date of purchase.

The manufacturer undertakes to replace any spare parts that are classified as defective by an appointed Mitox service dealer. The manufacturer will not accept liability for the replacement of the machine, either partially or wholly, and /or consequential damages and /or interest charges either directly or indirectly.

Warranty does not cover failure due to:

Insufficient maintenance.
Incorrect fuel mixture and stale fuel.
Abnormal use or accidental damage.
Incorrect assembly, adjustment or operation of the product.
Spare parts that are subject to wear e.g. bag, blades, bearings, cables, guards, deflectors, spark plugs, air filters etc.

Neither does warranty extend to:

Freight and packing costs.
Use of non-genuine spare parts i.e. those from another manufacturer.
Use of the machine for any other purpose than that for which it was designed.
Use and maintenance of the machine in a manner not described in the owner's manual.

As part of our policy of continuous product improvement, we reserve the right to alter or amend this specification without notice. As a result, the product may differ from the information contained herein but any alteration will only be implemented without notice if it is classified as an improvement to the above specification.

READ THE MANUAL CAREFULLY BEFORE OPERATING THE MACHINE

When ordering spare parts, please quote the part number, this can be found in the parts list included in this manual.

Retain your proof of purchase, without which no warranty can be offered.

Mitox Garden Machinery, Wincanton Business Park, Wincanton, Somerset, BA9 9RS