

# INSTRUCTION MANUAL

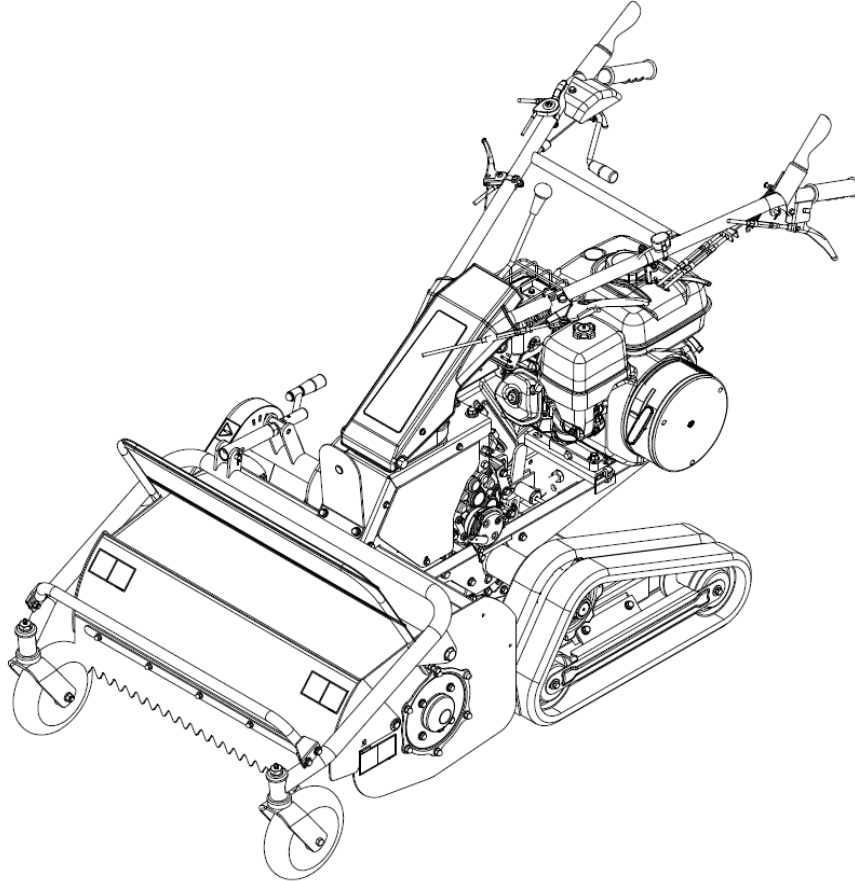

**HRC663/673/813**



## **Grassland walk behind flail mower**



**Read this instruction manual carefully before any use of the machine, keep it as a reference. For any question about this manual, please report to your OREC dealer or to the distributor of your country or to : <http://www.orec-jp.com>.**

Update : June 2020

## **INTRODUCTION**

### Forward to the user

Read this manual before any use of your mower, only the herein instructions shall help you to achieve an efficient and safe work.

A safe use will only result from the manner you will use the machine in accordance with the restrictions described in this manual. Thus, you must know and follow **all** the safety measures in this manual and those relating to the use of your mower.

The MOWER that you have just bought has been designed and manufactured for your entire satisfaction. As any other mechanical machine, it requires a proper maintenance and must be kept clean. Grease the machine like indicated. Follow the rules and safety indications as described in this manual and as showed on the preventive instruction stickers.

About maintenance, always mind that your OREC dealer has the skills, the genuine parts and the necessary tools to solve the possible problems.

Use only the OREC original parts : “ non genuine ” parts will not assure you of a correct and safe working and are likely to make the guarantee null and void. Write the name and the serial number of your machine hereunder :

MODEL :.....

SERIAL NUMBER (refer to the pictures herein) :.....

Always mention these information to your dealer in order to obtain the right parts.

Concerned about constant progress, OREC keeps the right to modify the machines without being compelled to modify those already sold.

The illustrations and characteristics in this manual might lightly differ from your machine because of the constant improvements made by our production department.

In this manual, the left and the right hand or the rear and the front position are determined according to the mower handlebar.

All along this manual the word **IMPORTANT** is used to indicate that a fault might cause damage to the machine. The words **WARNING**, **CAUTION** and **DANGER** are used with the “ safety/warning ” pictogram (triangle with an exclamation mark) in order to indicate a hazard for your safety.



This symbol indicates that you must be very attentive because your safety is at stake. It reminds that you must follow the safety instructions and pay attention to hazardous operations that might cause injuries.



Reminds the safety rules that might cause injury if they are not respected.



Remembers to pay attention to a real danger that is likely to cause injury or even death if no proper precaution is taken.



Indicates a major hazard that is most likely to cause irremediable injury or death if the right precautions are not taken.

## CONTENTS

INTRODUCTION .....	2
CONTENTS .....	3
SPECIFICATIONS .....	3
CHECK LIST .....	4
SAFETY RULES .....	5
DIFFERENT PARTS OF THE MOWER .....	6
SAFETY INSTRUCTION STICKERS .....	7
CONTROLS .....	9
OPERATION .....	12
MAINTENANCE OPERATIONS TO BE CARRIED OUT BY THE USER .....	14
BREAKDOWNS AND SOLUTIONS .....	21
TIGHTENING TORQUES (Nm).....	22
EC CONFORMITY DECLARATION .....	23
MEASUREMENT OF VIBRATIONS .....	23
EC CONFORMITY DECLARATION .....	24
MEASUREMENT OF VIBRATIONS .....	24
EC CONFORMITY DECLARATION .....	25
MEASUREMENT OF VIBRATIONS .....	25
LIMITED WARRANTY .....	26
NOTES.....	26

## SPECIFICATIONS

Model	HRC663	HRC673	HRC813
Engine	HONDA GX270	HONDA GX270	HONDA GX340
Engine power(HP)	8.45Hp	8.45Hp	10.7Hp
Transmission	Mechanical	Mechanical	Mechanical
Forward speed(km/h)	(1) 0.95, (2) 1.99, (3) 3.50	(1) 0.95, (2) 1.99, (3) 3.50	(1) 0.95, (2) 1.99, (3) 3.50
Reverse speed(km/h)	0.95	0.95	0.95
Cutting width (mm)	650	650	800
Height of cut (mm)	50 to 110	50 to 110	50 to 110
Weight (kg)	170	170	190
Fuel tank(liters)	5.3	4.1	4.7
Blade transmission	belts	belts	belts
Blade engagement	belt tension	belt tension	belt tension
blade speed (rpm)	3075	3075	3075
Over all width (mm)	810	810	940

## **CHECK LIST**

### **INSTRUCTIONS TO THE DEALER**

- The assembling, the installation and the first application of the machine is under the OREC dealer's responsibility.
- Read the instruction manual as well as the safety measures. Check that all the before delivery and at delivery check points specified in the following lists have been verified and possibly modified before delivering the machine to its owner.

### **CHECKS BEFORE DELIVERY**

- Check that all the shields, grids and safety guards are in place and in a good condition.
- Check that the hydraulic hoses are in place and in a good condition. Replace them if necessary.
- Check that there is no oil leak, repair if necessary.
- Check that the safety instruction stickers are in place and in a good condition. Replace them if necessary.
- Check that all the bolts and screws are properly tightened with the right torque (refer to torque chart).
- Protect the grease nipples by coating them with grease and lubricate the machine.
- Check that the machine can work properly.

### **CHECKS ON DELIVERY**

- Show the user how to perform the adjustments.
- Explain to the user the importance of the lubrication and show him the different greasing points on the machine.
- Show him the safety devices, grids, guards and the optional equipment.
- Give the instruction manual to the customer, ask him to read it carefully.

## SAFETY RULES



### CAUTION

Some of the illustrations show the machine with no guard, no shield. Never use the machine without these devices.

- Learn to stop the machine in case emergency.
- Read this manual.
- Do not let anybody use the machine before having read and understood this manual.
- Do not let children use the machine.
- Do not wear loose clothes. They might be grasped by moving parts.
- Always wear protection equipment when using the machine.
- Only work during daylight or with good artificial light.
- Check that the safety instruction stickers are in place and in a good condition.
- Keep the machine free from debris or mud.
- Check that the machine can work properly before any use.
- Check that all the shields, grids and safety guards are in place and in a good state.
- It is strictly forbidden to carry persons or animals onto the machine during the work or during the transportation.
- Never stop or start roughly when working on a slope. Never use the machine to work on a stepping terrain.

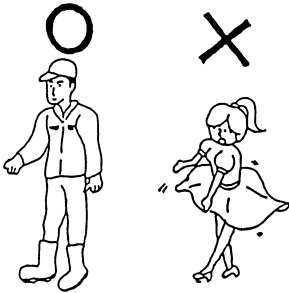

- Reduce the ground speed when running on a slope and when turning straight in order to prevent from any risk of losing control.
- Be very careful when bordering ditches.
- Stop the engine, and remove the sparking plug ignition cover before any intervention on the machine.
- Never work under the machine or its parts when lifted, unless they are blocked and maintained into position with sufficient security.
- **When running on a slope, basically work going up or down. In case of going across the slope, respect the limit angle on slope.**

- Steer clear of unsteady embankments, holes or rocks. They might be dangerous during manoeuvres or transport.
- Keep away from electric wires and obstacles. A contact with electric wires causes electrocution and death.
- Stop the engine when lifting or transporting the machine.
- When stopping the work, stop the engine and remove the sparking plug ignition cover before leaving the mower.
- Engage all the safety equipment.
- Move the controls only when correctly sat down in the mower
- Visually check hydraulic leaks and if some parts are faulty or missing. Repair before use.
- Never change the adjustment of the regulator, it is set in the factory. Unsetting this valve would cause failures.
- Ensure that the user of the machine has already read and understood this manual and is aware of all the safety instructions before any use.
- Always use a chuck and bronze hammer when replacing or intervening on the pins and bolts at the end of rams, rod ... etc. in order to avoid the projection of metal fragments.
- Clear the mowing path from foreign objects, stones, woods, cans, bottle, pieces of steel, which can be thrown by the mower.
- Gasoline is highly flammable :
  - Refuel outside, never smoke when refueling
  - Never refuel when the engine is running, stop the engine before refueling
  - Allowed the engine to cool down before refueling
  - If gasoline has spilled, do not try to start engine before the spilled gasoline has been wiped.
  - Check that the fuel cap is correctly installed after refueling

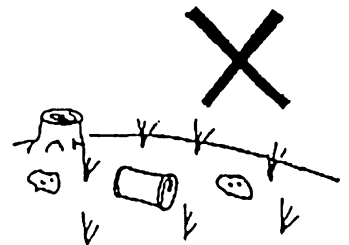

**DIFFERENT PARTS OF THE MOWER**

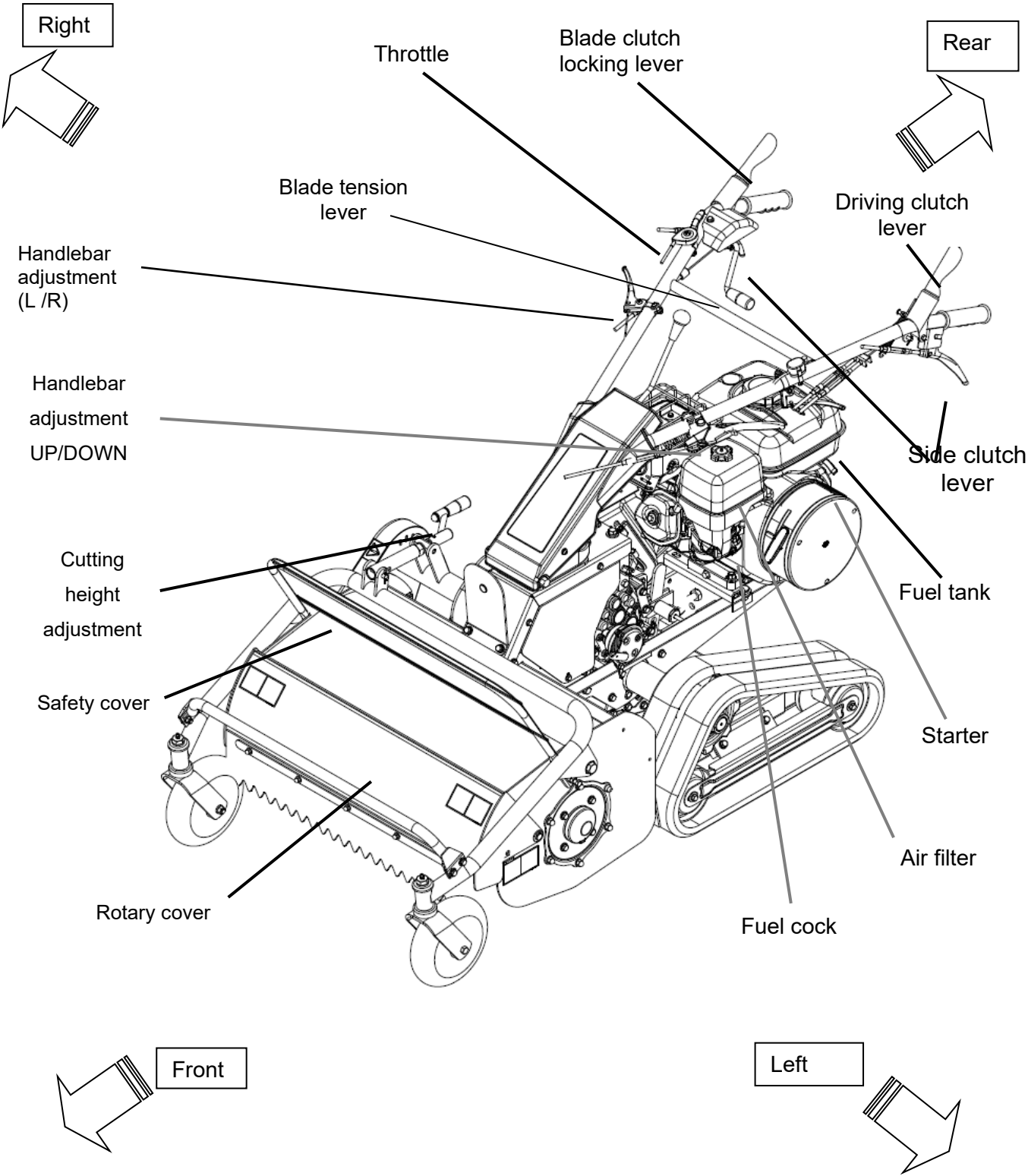

## SAFETY INSTRUCTION STICKERS

Note their location and replace them immediately in case of damaged or when missing



Unplug the spark plug wire before performing maintenance, read owner's manual



Beware of thrown objects



Keep away from the machine



Read owner's manual

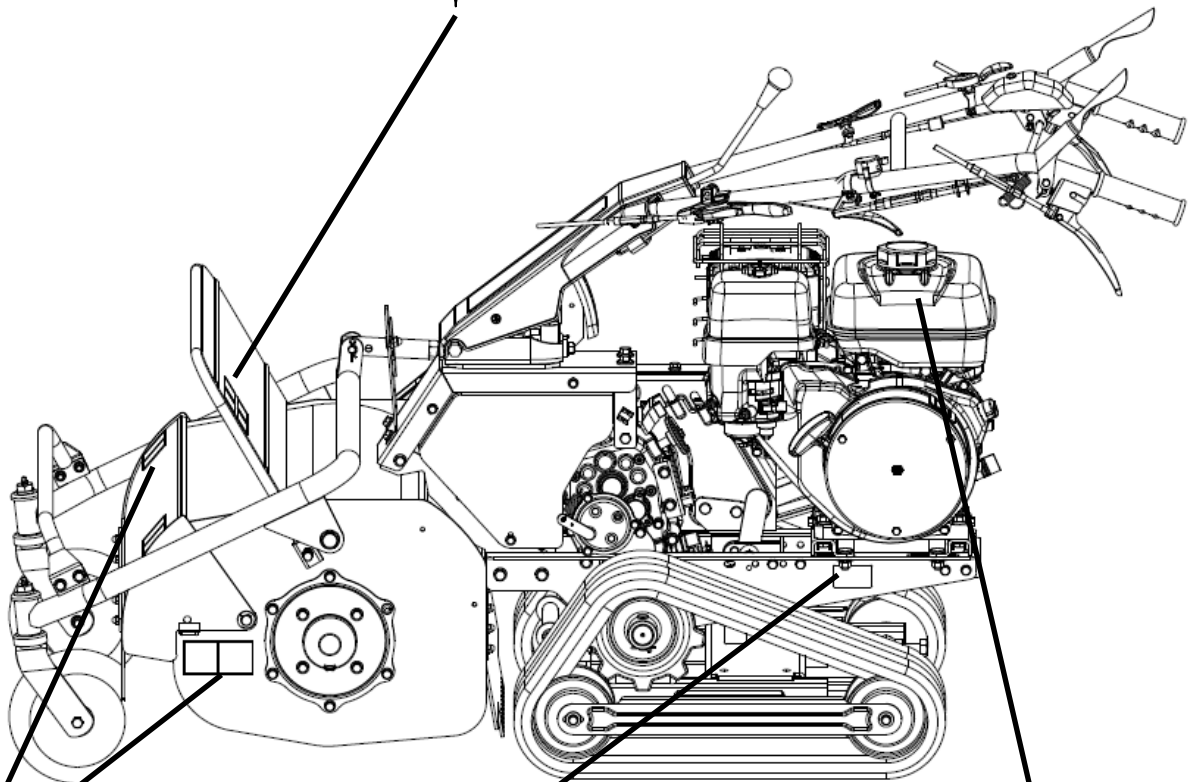

No hands or feet under the mowing deck

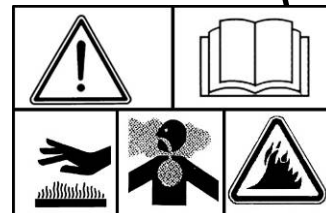

Read owner's manual to be aware of the risks such as burns, breathing intoxication, and fire

SAFETY INSTRUCTION STICKERS (continued)

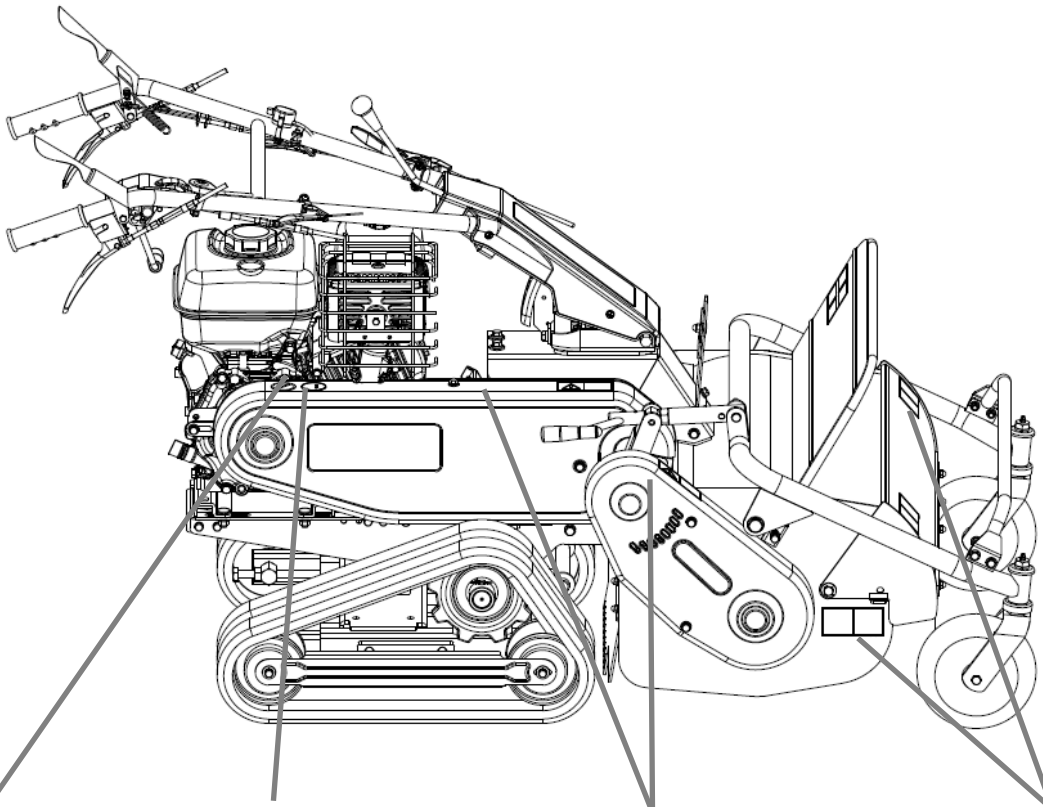

Do not exceed 15° slopes (HRC663)



Always wear protective equipment against dust, noise and wear glasses



Beware of rotative belt under the shield



No hands or feet under the mowing deck



Do not exceed 25° slopes (HRC673, 813)



## CONTROLS

### DRIVING CLUTCH LEVER

Push the lever (1, Figure 1) down to the handlebar to make the machine move. Release the lever, then the machine stops.

### BLADE CLUTCH LEVER

Blade clutch lever makes the engine drive the blade to mow. Push the lever (2, Figure 1) then pull up the lever (3, Figure 1) to make the blade spin. Release the lever, then the rotor stops.

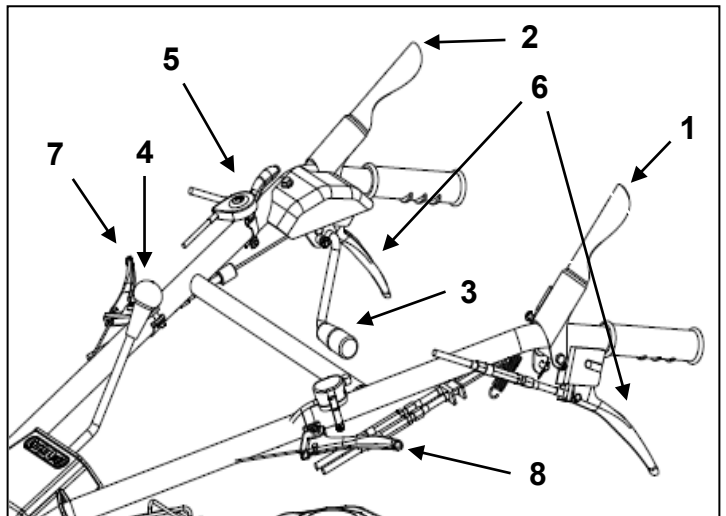

Figure 1



**WARNING**

**Never try to start or stop the engine with blade engaged.**

### SPEED LEVER

This lever (4, Figure 1) allows to select 3 forward speeds (1, 2, 3), 1 reverse speed (R) or 1 neutral position(N).



**WARNING**

**Be sure to change speed only when driving clutch is disengaged and machine is stopped.**

### THROTTLE LEVER

Push the throttle lever (5, Figure 1) to left to increase engine speed, push the throttle lever to right to decrease engine speed to idle rpm. Always operate mower at full engine speed.

### SIDE CLUTCH LEVERS

The side clutch levers (6, Figure 1) are used to change the direction of the machine. Grip right lever to turn right and left lever to turn left. To move the machine when engine is cut off, grip the both levers.



**DANGER**

**Do not grip two levers on slopes when engine is running.**

### HANDLEBAR ADJUSTMENT LEVERS

Grip the lever (7, Figure1) to move handlebar right and left. And grip the lever (8, Figure 1) to move handlebar up/down.

### CHOKE LEVER (1, FIGURE 2)

Push this lever to X to operate the choke to start engine cold, when engine has start release it to Y.



Figure 2

### **IMPORTANT**

**There is no need to choke when the engine is hot.**

**FUEL COCK (2, FIGURE 2)**

Open fuel cock before using the machine. Close fuel cock when machine is not in use. Push the lever to Y to open fuel cock and to X to close cock.

**HEIGHT OF CUT CONTROL**

Height of cut can be adjusted by turning the crank-lever (1, Figure 3) clockwise to increase the height of cut and anti-clockwise to lower the height of cut.

**⚠ WARNING**

**Always perform this adjustment with engine off and sparking plug cover unplugged. When cutting low, more power is needed and more objects are thrown. Cutting low can cause damage to the machine and injuries.**

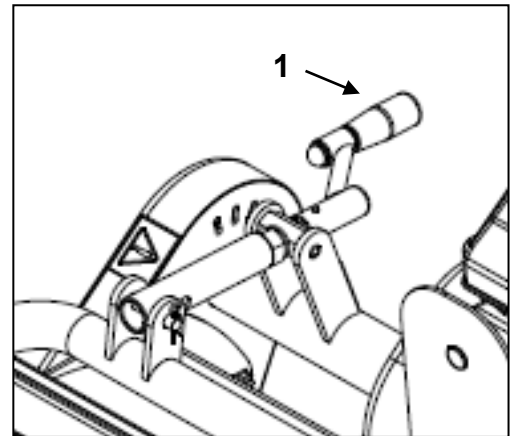

Figure 3

**ENGINE ON/OFF SWITCH**

This switch is located on the left side of the handlebar. It allows to run the engine when positioned on « ON » and stop the engine when positioned on “OFF”. (Figure 4) Use this switch to start or stop the engine.

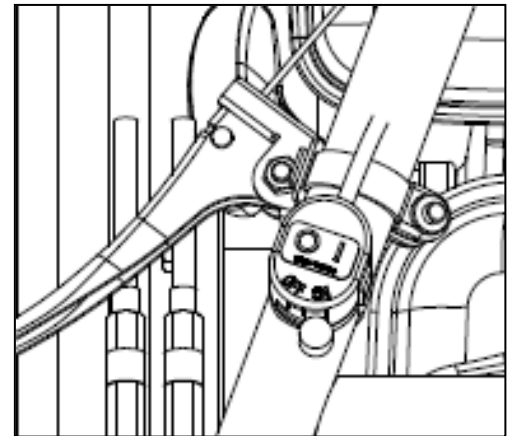

Figure 4

**ENGINE :**

Refer to engine manual delivered with the machine.

**CRAWLER LOCK LEVER ( HRC673 / 813 ONLY)**

This lever is located on the left side of handlebar. It is used to function for uplift prevention of machine by locking both crawlers.

Grip the lever (1, Figure 5) until it clicks into place and is locked by lever (2, Figure 5). In this moment, crawler is unlocked.

Grip lever (1, Figure 5) again with lever (2, Figure 5) and release it. Then crawler kit pin should fit into one position. Then crawler is locked.

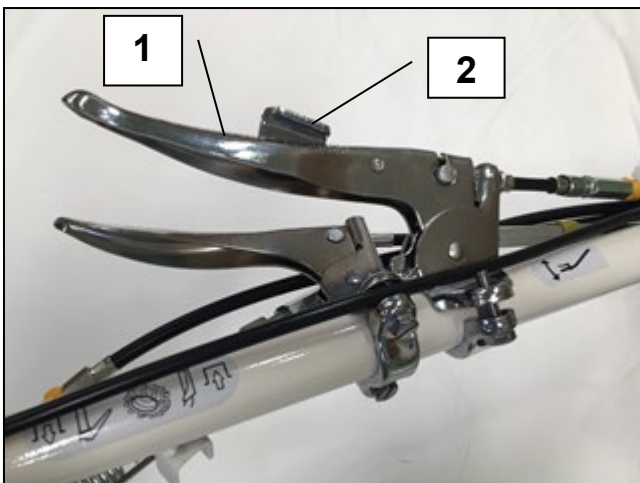

Figure 5

**⚠ CAUTION**

**When crawler is locked, turning radius would be slightly bigger than normal operation.**

**ROTARY COVER (1, FIGURE 6)**

The blade spins at a high speed inside the cover. This cover prevents cut grass and foreign objects from scattering.

**FRONT COVER (2, FIGURE 6)**

This opens and closes automatically depending on the quantity of grass. This prevents cut grass and foreign objects from scattering forward.

**SAFETY COVER (3, FIGURE 6)**

This prevents cut grass and foreign objects scattering from coming at the mower.

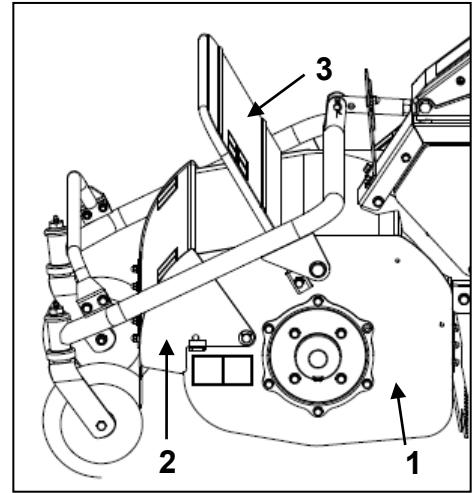

Figure 6

** WARNING**

**The covers are the really important parts to protect from thrown objects.**

**Do NOT attempt to operate the machine if the covers are in abnormal conditions. Make sure to follow the instruction below.**

- 1. If Rotary cover, Front cover or Safety cover is damaged or deformed, have it repaired or replaced.**
- 2. Do NOT attempt to operate the machine without Front cover and Safety cover.**
- 3. Do NOT attempt to operate the machine with Front cover fixed. Fix Front cover ONLY when replacing the blade or cleaning inside of the cover.**

## OPERATION



**CAUTION**

### **Check the tightening of bolts, referring to the tightening torque chart**

The safety is one of our main worries when designing and manufacturing this machine. Negligence in the use of the machine spoils our efforts. The prevention strictly depends on the care and on the skill of the user when applying and maintaining the machine. The best safety method remains a careful and skilled user ; we hope you to be this kind of user.

The user of this machine is responsible for its safe use. He must be a skilled user specially trained for the use of this machine. Read the safety instructions. This machine has been designed to mow grass. It is not designed for any other operation. It is not designed to transport other tools or materials that might damage it and cause injuries to the user. It must not be used to carry persons.



**DANGER**

**Never use the machine without having priory carried out all the maintenance operations as described in the daily maintenance chapter.**



**CAUTION**

**Never let children or unskilled persons use the machine. Check that nobody or no objects stands near the machine when at work. They could be hit by the moving parts. Nobody must stand on the machine except the driver. Never put your hands under moving parts.**

### **STARTING OF THE ENGINE**

- Turn the fuel cock to "ON".
- Check that cutting blade is disengaged, and Driving lever range is in neutral position « N ».
- Push choke lever if engine is cold or push throttle lever half of his stroke if the engine is hot.
- Pull the starter rope.
- When the engine has started, pull back the choke lever.
- Select a speed ratio and travel to the mowing path.

### **DRIVING ON SLOPES**

Driving on a slope is very dangerous. For your safety, never work on a more than 15° (HRC663) / 25° (HRC673 / 813) slope. Also, be careful even when you work on a slope of less than the limited degree. The unit might tip over depending on field condition.

**Basically, drive up or down.**

**In case of driving across the slope, it is safe to turn from low level to high level(Figure 7). If machine is turning from high level to low level, it is difficult to turn properly and it is very dangerous.**

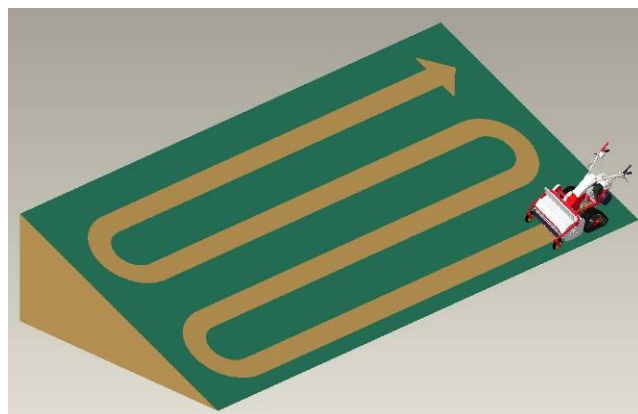

Figure 7



**WARNING**

**It is very dangerous to disengage the driving clutch on slopes unnecessarily or to shift the change lever into neutral position.**

### **MOWING**

- Start the engine
- Adjust the height of cut as needed.



### **WARNING**

Do not forget that it is better to mow grass regularly. Remember that the machine gets deteriorated rapidly in the hot and dry weather. When cutting height is low, the blade may hit the ground and get damaged. The user and bystanders are likely to get injured by the thrown objects. The thrown objects may cause damage to properties.

- Increase engine speed to the maximum.
- Push down the blade clutch lever (1, Figure 8) then engage the blade tension lever (2, Figure 8) slowly.
- Then go forward in the grass to mow.
- The best cutting speed depends on quantity and the density of the grass. Usually, it is asked to mow between 1st and 2nd speed. Tall grass should be cut slowly and short grass can be cut faster.

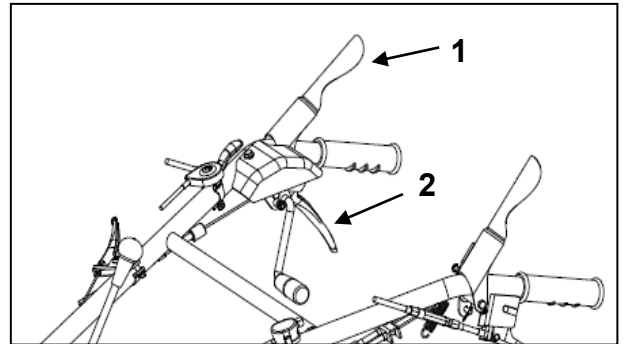

Figure 8



### **CAUTION**

Clear the mowing path from foreign objects, stones, woods, cans, bottles and pieces of steel which can be thrown by the mower. They can cause injury to the operator or the bystanders.

### **HOW TO STOP THE MACHINE**

- Release drive clutch lever and blade clutch lever.
- Push the throttle lever to "LO".
- Switch the engine stop on "off"
- Close the fuel cock
- Remove the spark plug wire



### **CAUTION**

Never park the machine on slopes. Park it on a level and flat surface.

### **STORING THE MACHINE**

Thoroughly clean the machine. Use touch up paint to prevent rust. Check for worn and damaged parts, install new parts as required. Perform the normal maintenance of the machine according to maintenance chart. Store the machine in a dry protected area. Remove sparking ignition wire from the sparking plug.

### **TRANSPORT**

- Check that the cutting rotor is disengaged.
- Check that the spark plug cover is disconnected.
- Check that the fuel cock is closed.



### **CAUTION**

Take care of hot surfaces of the machine, especially around the engine.

## **MAINTENANCE OPERATIONS TO BE CARRIED OUT BY THE USER**



**DANGER**

**BEFORE performing any maintenance operation on the machine, stop the engine, and remove the spark wire from the sparking plug.**

If maintenance operation is not realized, the machine can get damaged easily and cause personal injuries to the user and/or bystanders. These damages and injuries will not be covered by the warranty.

- Daily maintenance should be performed by the user.
- Maintenance operations for first 20 hours, 100 and 300 should be realized by the dealer.
- Ask your dealer to check the machine if you find some problems.
- Ask your distributor the name of your dealer.

### **DAILY MAINTENANCE, BEFORE START MOWING**

Transmission oil level : Loosen the bolt of the oil gauge (1 Figure 9), if the level is correct, the oil level should appear in the gauge.

Transmission oil replacement.

- Gear Oil : SAE90 or API GL-5
- Gear Oil Quantity : 1.60L

Put a container under the right side of the transmission to receive old oil, remove the drain plug (3 Figure 10). Then, fix the drain plug (3 Figure 10). Put the oil from the oil cap (2, Figure 9)

Oil Exchange Frequency

First : 20 hours

Later : each 100 hours or every year whichever comes first

### **FUEL (FIGURE 11)**

Check tank level is full before start to work. Check that tank cap is fully closed, and check for leaks. Use only good quality unleaded gasoline.



**DANGER**

**Check fuel tank is closed, wipe fuel spillages before start the machine. Check there is no fire, electric sparks, cigarettes near the machine when refueling.**

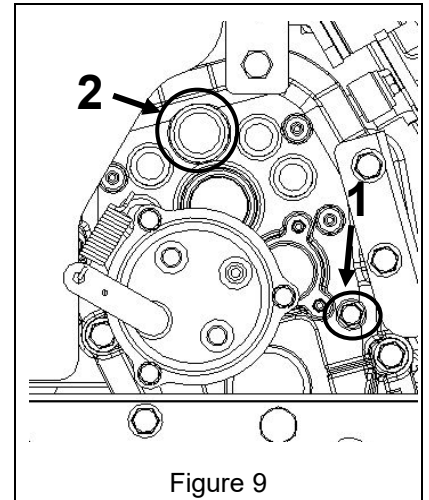

Figure 9

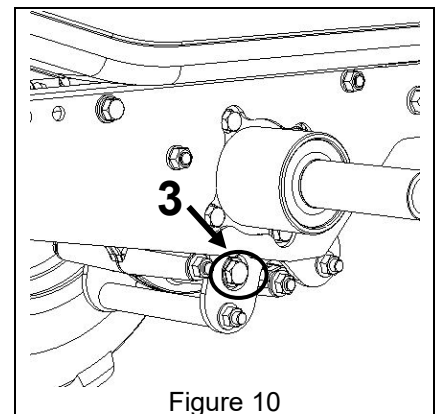

Figure 10



Figure 11

**SAFETY STICKERS**

- Check safety stickers are labeled on their place. Replace them if they are worn and damaged.

**AIR FILTER**

- Open the air cleaner cover and remove the dual-filter elements.
- Remove the foam filter element from the paper filter element.
- Clean paper filter element with compressed air (read the engine manual).
- Clean foam filter element with soapy water, and dip in oil (read the engine manual).
- Install the elements and air cleaner cover referring the engine manual.

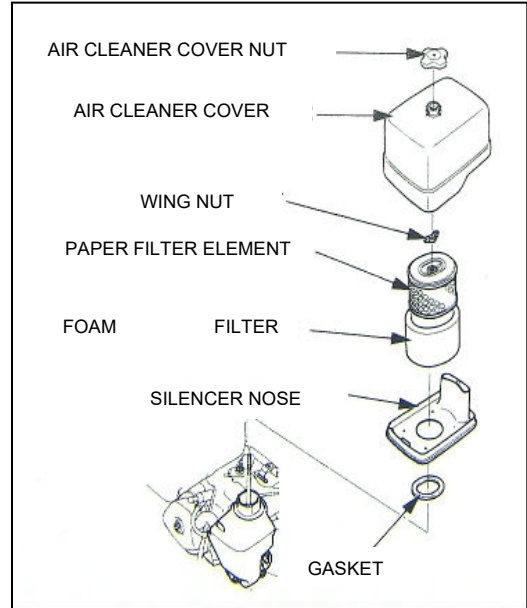

Figure 12

**ENGINE OIL LEVEL :**

- Refer to engine manual. With the engine cold or stopped at least for 10 minutes on a level place. Check level with the oil filter cap (1, Figure 13). Unscrew the plug, wipe it and install without screwing it. Check the level. That must be between the two marks.
- Engine oil : SAE 10W30 or API SL class
- Engine oil quantity : 1.10L (HRC663)  
1.28L (HRC673/813)

Remove oil drain plug (2, Figure 13) in case of changing oil.

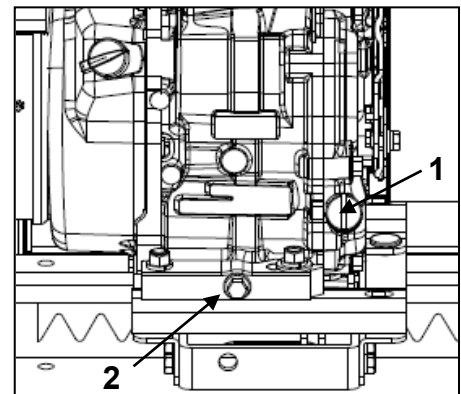

Figure 13

Engine oil replacement

First : 20 hours.	Later : every 100 hours or every year whichever comes first.
-------------------	--

**BLADE AND BLADE HOLDER CONDITION**



**You can be cut and injured by cutting flails. Always wear gloves when holding flails.**

Check if flails are in good condition. Change worn or damaged parts.

- Changing flails : unscrew hexagonal bolt on the rotor.
- Check the blade condition. Change it if it is worn, bent or cracked.
- Reverse flails if the cutting side is worn out in order to use the other side.
- Check that ALL the flails of the rotor are bolted and in good condition
- Check tightening of hexagonal screws according to the chart at the end of the manual.



Figure 14

**⚠ CAUTION**

Use only original genuine OREC parts. Other parts may be dangerous for your health and for the bystanders and the machine. If some flails are missing, big vibrations will occur. If you feel such vibrations on the handlebar, check the rotor and the flails. Vibrations may loosen the bolts and nuts and may crack the steel of the machine.

**TIGHTENING OF BOLTS AND NUTS**

- Check for tightening of bolts and nuts according to the chart. Vibrations of the machine may loosen bolts and nuts.

**LUBRICATION :**

- Grease the front wheel axle (1, Figure 15) with grease NLGI N°2.
- Grease the different points (G, Figures 16,17) with light oil.



Figure 15

Figure 16

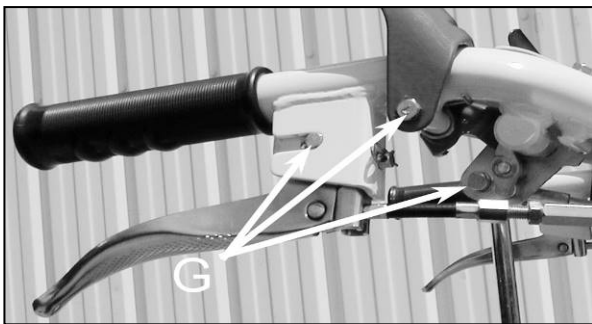

Figure 16



Figure 17

**WIRES GAP :**

**Transmission wires :**

- If the machine does not stop when the drive clutch lever is released, adjust the tension wire as follow : unscrew the locking screw (A, Figure 18) and unscrew the nut (B, Figure 18). Try the machine again. Perform the adjustment again if needed. When the adjustment is performed, screw the locking screw (A, Figure 18) on the nut (B, Figure 18).

- If the machine does not move when driving clutch lever is pressed, adjust the tension wire as follow : unscrew the locking screw (C, Figure 18) and unscrew the nut (D, Figure 18). Try the machine again. Perform the adjustment again if needed. When the adjustment is performed, screw the locking screw (C, Figure 18) on the nut (D, Figure 18).



Figure 18

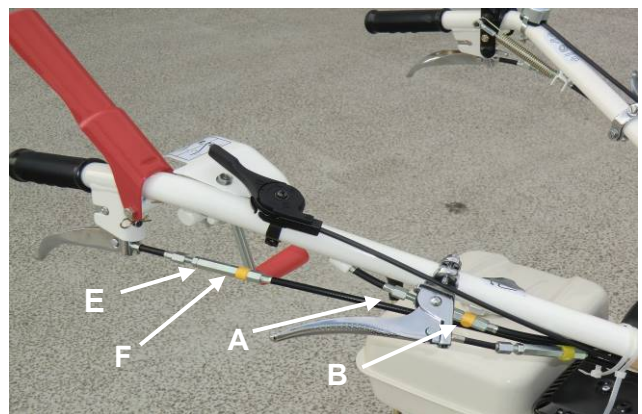

Figure 19



**Blade wire :**

- If the blade does not stop when the blade lever is released, adjust the tension wire as follow : unscrew the locking screw (A, Figure 19) and unscrew the nut (B, Figure 19). Try the machine again. Perform the adjustment again if needed. When the adjustment is performed screw the locking screw (A, Figure 19) on the nut (B, Figure 19).
- If the blade does not move when transmission lever is pressed, adjust the tension wire as follow : unscrew the locking screw (A, Figure 19) and after screw the nut (B, Figure 19). Try the machine again. Perform the adjustment again if needed. When the adjustment is performed screw the locking screw (A, Figure 19) on the nut (B, Figure 19).



**Blade brake is connected to the blade wire. Check if the blade brake works correctly when adjusting blade wire control.**

**Direction wires :**

If the wheel is not locked with side clutch lever engaged, adjust as follows:

- Unscrew locking nut (E, Figures 18,19).
- Screw or unscrew the nuts (F, Figures 18,19) .
- Try the machine.
- Adjust again if it is necessary.
- Screw the locking nut “E” on the adjusting nuts “F”.

**Handlebar Control wire adjustment**

If the handlebar control doesn't work correctly, adjust as follow :

- If it is difficult to free the handlebar, unscrew the nut (A, Figure 20,21), then screw the nut B to increase the wire tension. When the adjustment has been performed, screw the nut A again.
- If the handlebar doesn't lock properly, unscrew the nut (A, Figure 20,21), then unscrew the nut A to decrease the wire tension. When the adjustment has been performed, screw the nut B again.

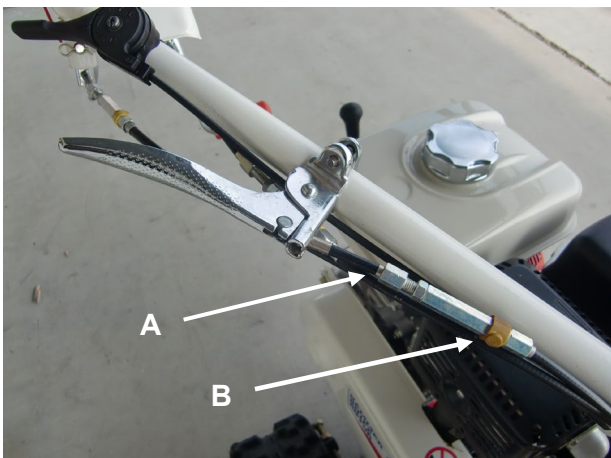

Figure 20

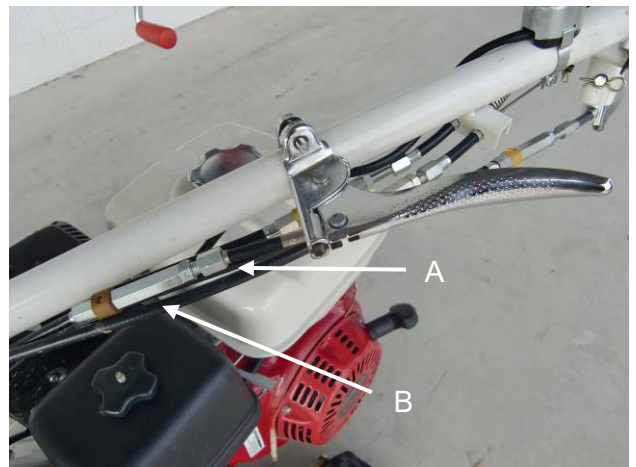

Figure 21

**BELTS ADJUSTMENT:**



**WARNING**

A loosened belt may slip and get worn quickly, a too tightened belt may wear out bearings.

- Check for belt condition, cracks and wear. Replace if necessary.

**Belt from engine to counter shaft**

- Stop engine and disconnect sparking cover, clutch the blade.
- Unscrew the three bolts of the shield to reach the belts.
- Push the belt with a finger on (A, Figure 22) the belt must move from 10 to 12 mm. If the belt does not move accordingly, perform “tension wire” again.
- Check that the belt guides (B, Figure 22) are close 3 or 4 mm from the tighten belt.
- If it is necessary, adjust the belt guides as follow : unscrew bolt (C, Figure 22) and adjust belt guides as required and screw the bolt again.
- Fit the belt cover with the three bolts.

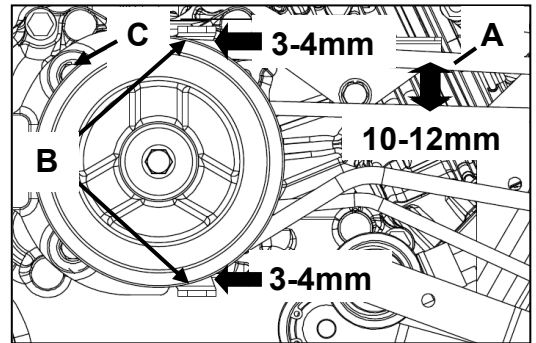

Figure 22

**Belt from the counter shaft to the flails**

- Stop engine and disconnect sparking cover.
- Unscrew the 2 bolts of the shield to reach the belt.
- Push the belt with a finger on (F, Figure 23) the belt must move from 3 to 5 mm. If the belt does not move accordingly, adjust with screws (A, Figure 23) & (B, Figure 23)
- Fit the belt cover with the two bolts.

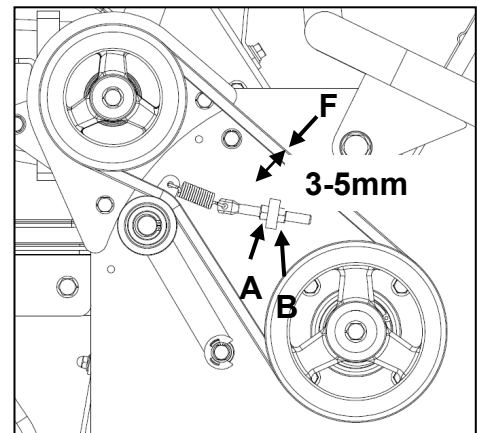

Figure 23

**Belt transmission adjustment**

- Stop engine and disconnect sparking cover, clutch the blade.
- Unscrew the three bolts of the shield to reach the belts.
- Push the belt with a finger on (A, Figure 24) the belt must move from 12 to 14 mm. If the belt does not move accordingly, perform “tension wire” again.
- Fit the belt cover with the three bolts.

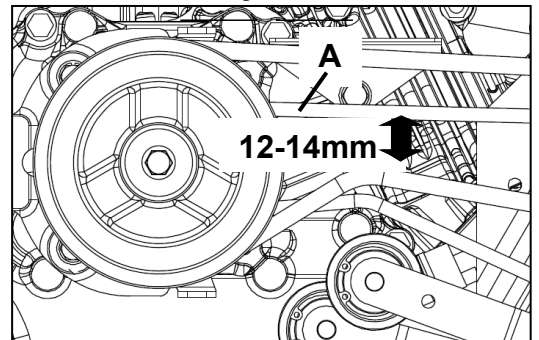

Figure 24

**BLADE BRAKE :**



**WARNING**

Check the blade brake every month (1, Figure 25), check the time for the blade to stop when blade clutch lever is released. If more than 7 seconds are necessary for the blade to stop, ask your dealer immediately to check the blade brake system.

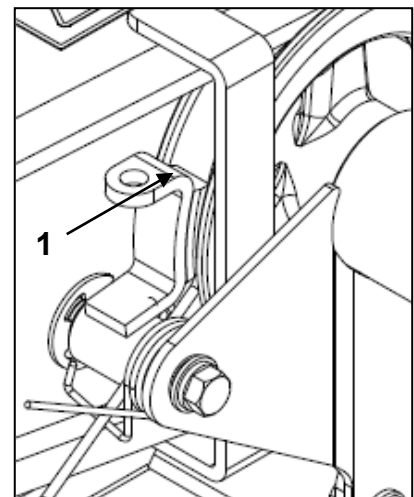

Figure 25

## CRAWLER ADJUSTMENT



**Crawlers tend to be stretched at first and gradually get suited for the sprocket.**

When the tension of crawler is not adjusted correctly, the crawlers might be taken off, or the life time can be shortened. Adjust crawler tension as follows.

Check crawler tension every 50 hours of use.

1. Remove the crawler cover and bolt.
2. Loosen locknut (A, Figure 27) in the rear part of the machine.
3. Turn the tension bolt (B, Figure 27) clockwise to increase the crawler tension and counterclockwise to decrease.
4. The free play of the belt should be between 10 to 20 mm by pushing with hand.
5. Adjust crawler tension, both side crawler should be the same tension.
6. After adjusting, fix locknut certainly and crawler cover.

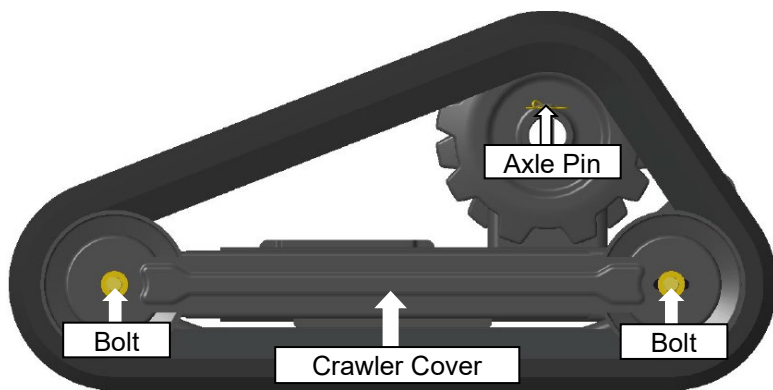

Figure 26

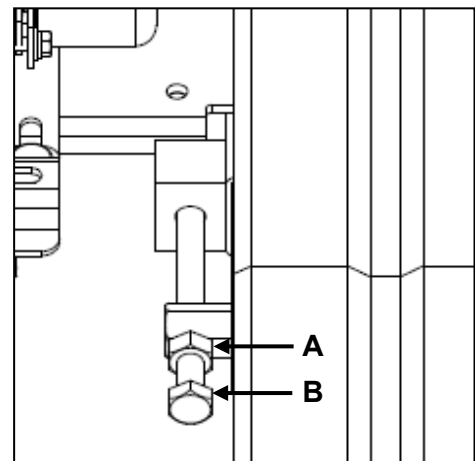

Figure 27

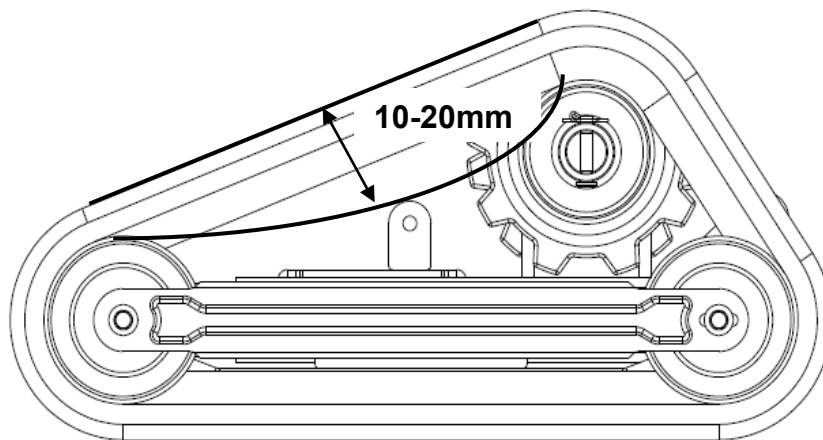

Figure 28

**MAINTENANCE CHART**

Accidents or troubles can be caused if you do not inspect and maintain the machine. Inspect and maintain as below in order to keep the machine work good and safe.

\* For engine, refer to engine manual.

Frequency : D / Daily  
M / Monthly  
Y / Yearly

PART	INSPECTION	DETAIL	FREQUENCY		
			D	M	Y
Belt	tension	Tension is right.	<input type="radio"/>	<input type="radio"/>	<input type="radio"/>
	damage, stains and dirt	There are no cracks, damage or excessive dirt.	<input type="checkbox"/>	<input type="radio"/>	<input type="radio"/>
Transmission	strange noise and heat	There are no strange noise or heat.	<input type="checkbox"/>	<input type="radio"/>	<input type="radio"/>
	oil gauge and dirt	Transmission oil level is adequate and the oil is not excessively dirty.	<input type="checkbox"/>	<input type="checkbox"/>	<input type="radio"/>
	oil leakage	There are no visible oil leaks from oil seal and packing.	<input type="radio"/>	<input type="radio"/>	<input type="radio"/>
Body Frame	cracks, deformation bolts and nuts	There are no cracks or deformation. Bolts and nuts are in place and tight.	<input type="checkbox"/>	<input type="radio"/>	<input type="radio"/>
Cover	cracks, deformation, corrosion	There are no cracks, deformation, or corrosion.	<input type="checkbox"/>	<input type="checkbox"/>	<input type="radio"/>
Flapper	damage, defects and loss	There are no damage, defects or loss.	<input type="radio"/>	<input type="radio"/>	<input type="radio"/>
Lever Wire Crawler	damage, loose split pins loss	There are no noticeable damage, loosening. Split pins are in place.	<input type="radio"/>	<input type="radio"/>	<input type="radio"/>
	tension (crawler)	Tension is right.	<input type="radio"/>	<input type="radio"/>	<input type="radio"/>
	cracks, damage, wear-out	There are no cracks, damage or wear-out.	<input type="radio"/>	<input type="radio"/>	<input type="radio"/>
	stuck metal pieces, stones or etc.	There are no metal pieces, stones or etc. stuck.	<input type="radio"/>	<input type="radio"/>	<input type="radio"/>
	loosening or loss of bolts and nuts	Bolts and nuts are in place and tight.	<input type="radio"/>	<input type="radio"/>	<input type="radio"/>
	strange noise and loosening	There are no loosening or strange noise.	<input type="checkbox"/>	<input type="radio"/>	<input type="radio"/>
Blade Rotary	damage and balance of blade	Blades are not broken, chipped, cracked or bent. Blades are balanced.	<input type="radio"/>	<input type="radio"/>	<input type="radio"/>
	loosening of blade setting bolt	Blade setting bolts are in place and tight.	<input type="radio"/>	<input type="radio"/>	<input type="radio"/>
	rotary cover	There are no cracks, deformation, or corrosion.	<input type="checkbox"/>	<input type="radio"/>	<input type="radio"/>
Label	damage	All safety stickers are in place and legible.	<input type="checkbox"/>	<input type="radio"/>	<input type="radio"/>

## **BREAKDOWNS AND SOLUTIONS**

If you face with the problems below, refer to “solution” and take the appropriate action.

\* For engine, refer to engine manual.

<b>PROBLEM</b>	<b>POSSIBLE CAUSE</b>	<b>SOLUTION</b>
Cut grass is not discharged well.	Grass is wet.	Wait until grass sets dry.
	Grass is tall.	Mow with higher cutting height first.
	Cutting height is too low.	Raise the cutting height.
	Engine power is too low.	Increase the power to the max.
	Mowing speed is too high.	Decrease the speed.
Some grass remains.	Mowing speed is too high.	Decrease the speed.
	Engine power is too low.	Increase the power to the max.
	Blade is blunt, worn out or broken.	Replace the blade with a new one.
	Some grass is stuck inside of rotary cover.	Clean up and take out grass inside of the cover.
	Grass is tall.	Mow with higher cutting height first.
Cut into the ground.	Cutting height is too low.	Raise the cutting height.
	Turning speed is too high.	Turn slowly.
	The ground is wave-shaped.	Change the direction of mowing.
	The ground is bumpy and has many ups and downs.	Raise the cutting height.
	Blade is bent or deformed.	Replace the blade with a new one.
Belts are slipping.	Belt tension is too low.	Adjust belt tension.
	Foreign objects are stuck inside of rotary cover.	Clean up inside of the cover.
	Some grass is stuck on pulley.	Clean up pulley.
	Belt is worn out.	Replace the belt with a new one.
Cannot change mowing speed.	Gear position is misaligned.	Adjust change wire.
	Fault of transmission.	Repair the transmission.
There is big vibration.	Blades are poorly balanced.	Replace all blades.
	Blade is damaged.	Replace the blade with a new one.
	Blade drum is bent.	Replace Blade drum ASSY with a new one.
	Belt is broken.	Replace the belt with a new one.
	A new blade and an old blade are installed.	Do not install new and old blades together.
	Some grass is stuck on blade drum.	Remove the stuck grass on blade drum.
Mowing workload is heavy.	Engine power is too low.	Increase the power to the max.
	Mowing speed is too high.	Decrease the speed.
	Some grass is stuck on/around blade shaft.	Clean up the blade.
	Grass is tall.	Mow with higher cutting height first.
	Cutting height is too low.	Raise cutting height.
Tires are slipping.	The ground is soft.	Wait until the ground gets dry.
Fuel cap popped out.	Too much transmission oil (Too high internal pressure)	Take out some oil to the recommended level.

\* If you have any questions or do not understand any points, please contact your dealer.

## TIGHTENING TORQUES (Nm)

Diameter of screw(mm)	Mark on the screw head				
	4 Or without mark	7	8	9	11
3	0.3~0.5	---	---	---	---
4	0.8~1.0	---	---	---	---
5	2.5~3.4	5.4~6.4	6.4~7.4	6.4~7.4	8.8~9.8
6	4.9~6.9	9.8~11.8	11.8~13.7	11.8~13.7	14.7~16.7
8	11.8~16.7	24.5~29.4	29.4~34.3	34.3~36.2	36.3~41.2
10	20.6~29.4	39.2~44.1	49~53.9	49~53.9	72.6~82.4
12	44.1~53.9	83.4~93.2	93.2~107.9	93.2~107.9	122.6~137.3
14	63.7~78.5	117.7~132.4	132.4~147.1	147.1~166.7	205.9~225.6
16	88.3~107.9	152~171.6	176.5~196.1	215.8~245.2	313.8~343.2
18	117.7~137.3	205.9~235.4	245.2~274.6	313.8~343.2	441.3~470.7
20	147.1~166.71	235.4~274.6	313.8~353	441.3~480.5	617.8~657.1
22	176.5~205.9	421.7~451.1	539.4~578.6	608~647.2	843.4~882.6
24	235.4~264.8	539.4~568.8	706.1~745.3	784.5~823.8	1098.4~1137.6

## **EC CONFORMITY DECLARATION**

Business name and full address of the manufacturer : OREC CO LTD 548-22  
HIYOSHI HIROKAWA-MACHI  
YAME-GUN FUKUOKA JAPAN  
S.A.T. sarl - Force 7 – ZA –  
38110 ROCHETOIRIN  
France owner of the technical documents  
walk behind grassland Mower

Designation :  
Mark : OREC  
Type : HRC663  
Serial Identification :  
Engine :  
- Manufacturer : HONDA  
- type : GX270  
- Power : 6,3 kW  
Width of cut : 650 mm  
Conforms to directives: 2000/14/EC, 2006/42/EC, 2014/30/UE  
Conformity assessment : 2006/42/EC Annex VIII  
Measured acoustic power level : 101.8 dB(A)  
Granted acoustic power level : 102.3 dB(A)  
Conformity assessment : 2000/14/EC Annex V  
Acoustic pressure level at operator's ears : 89.9 dB(A)  
Harmonized standards used : EN ISO 12733-2009, EN ISO 3744-2011  
EN ISO 3746-2011, EN ISO 1032/A1- -2008  
EN ISO 20643-2008

made at : Fukuoka, October 19, 2018

Signed : Haruhiko Imamura  
Function : Managing director



## **MEASUREMENT OF VIBRATIONS**

Mark : OREC      Type : walk behind grassland Mower  
Engine : GX270 ---HRC663

Accelerometer Position	HRC663
100mm from external side of handlebar(Left side)	3,64 m/s <sup>2</sup>
100mm from external side of handlebar(Right side)	3,15 m/s <sup>2</sup>

## **EC CONFORMITY DECLARATION**

Business name and full address of the manufacturer : OREC CO LTD 548-22  
HIYOSHI HIROKAWA-MACHI  
YAME-GUN FUKUOKA JAPAN  
S.A.T. sarl - Force 7 – ZA –  
38110 ROCHETOIRIN  
France owner of the technical documents  
walk behind grassland Mower

Designation :  
Mark : OREC  
Type : HRC673  
Serial Identification :  
Engine :  
- Manufacturer : HONDA  
- type : GX270  
- Power : 6,3 kW  
Width of cut : 650 mm  
Conforms to directives: 2000/14/EC, 2006/42/EC, 2014/30/UE  
Conformity assessment : 2006/42/EC Annex VIII  
Measured acoustic power level : 101.8 dB(A)  
Granted acoustic power level : 102.3 dB(A)  
Conformity assessment : 2000/14/EC Annex V  
Acoustic pressure level at operator's ears : 89.9 dB(A)  
Harmonized standards used : EN ISO 12733-2009, EN ISO 3744-2011  
EN ISO 3746-2011, EN ISO 1032/A1- -2008  
EN ISO 20643-2008

made at : Fukuoka, October 19, 2018

Signed : Haruhiko Imamura  
Function : Managing director



## **MEASUREMENT OF VIBRATIONS**

Mark : OREC      Type : walk behind grassland Mower  
Engine : GX270 ---HRC673

Accelerometer Position	HRC673
100mm from external side of handlebar(Left side)	3,64 m/s <sup>2</sup>
100mm from external side of handlebar(Right side)	3,15 m/s <sup>2</sup>



## **EC CONFORMITY DECLARATION**

Business name and full address of the manufacturer : OREC CO LTD 548-22  
HIYOSHI HIROKAWA-MACHI  
YAME-GUN FUKUOKA JAPAN  
S.A.T. sarl - Force 7 – ZA –  
38110 ROCHETOIRIN  
France owner of the technical documents  
walk behind grassland Mower

Designation :  
Mark : OREC  
Type : HRC813  
Serial Identification :  
Engine :  
- Manufacturer : HONDA  
- type : GX340  
- Power : 8,0 kW  
Width of cut : 800 mm  
Conforms to directives: 2000/14/EC, 2006/42/EC, 2014/30/UE  
Conformity assessment : 2006/42/EC Annex VIII  
Measured acoustic power level : 103.85 dB(A)  
Granted acoustic power level : 105 dB(A)  
Conformity assessment : 2000/14/EC Annex V  
Acoustic pressure level at operator's ears : 91,8 dB(A)  
Harmonized standards used : EN ISO 12733-2009, EN ISO 3744-2011  
EN ISO 3746-2011, EN ISO 1032/A1- -2008  
EN ISO 20643-2008

made at : Fukuoka, October 22, 2018

Signed : Haruhiko Imamura  
Function : Managing director



## **MEASUREMENT OF VIBRATIONS**

Mark : OREC Type : walk behind grassland Mower  
Engine : GX340—HRC813

Accelerometer Position	HRC813
100mm from external side of handlebar(Left side)	3,45 m/s <sup>2</sup>
100mm from external side of handlebar(Right side)	3,55 m/s <sup>2</sup>

