

INSTRUCTION MANUAL



Transporter LS 280 / LS360 / LS461



Compact Transporter



Read this instruction manual carefully before any use of the machine, keep it as a reference. For any question about this manual, please report to your OREC dealer or to the distributor of your country or to : <http://www.orec-jp.com>.

Update : September 2018

“Only the English version of this manual can be used as a reference.”

INTRODUCTION

Forword to the user

Read this manual before any use of your mower, only the herein instructions shall help you to achieve an efficient and safe work.

A safe use will only result from the manner you will use the machine in accordance with the restrictions described in this manual. Thus, you must know and follow all the safety measures in this manual and those relating to the use of your mower.

The mower that you have just bought has been designed and manufactured for your entire satisfaction. As any other mechanical machine, it requires a proper maintenance and must be kept clean. Grease the machine like indicated. Follow the rules and safety indications as described in this manual and as showed on the preventive instruction stickers.

About maintenance, always mind that your OREC dealer has the skills, the genuine parts and the necessary tools to solve the possible problems.

Use only the OREC original parts : “ non genuine ” parts will not assure you of a correct and safe working and are likely to make the guarantee null and void. Write the name and the serial number of your machine hereunder :

MODEL :.....
SERIAL NUMBER (refer to the pictures herein) :.....

Always mention these informations to your dealer in order to obtain the right parts.

Concerned about constant progress, OREC keeps the right to modify the machines without being compelled to modify those already sold.

The illustrations and characteristics in this manual might lightly differ from your machine because of the constant improvements made by our production department.

In this manual, the left and the right hand or the rear and the front position are determined according to the mower handlebar.

All along this manual the word **IMPORTANT** is used to indicate that a fault might cause damage to the machine. The words **WARNING**, **CAUTION** and **DANGER** are used with the “ safety/warning ” pictogram (triangle with an exclamation mark) in order to indicate a hazard for your safety.



This symbol indicates that you must be very attentive because your safety is at stake. It reminds that you must follow the safety instructions and pay attention to hazardous operations that might cause injuries.



Reminds the safety rules that might cause injury if they are not respected



Remembers to pay attention to a real danger that is likely to cause injury or even death if no proper precaution is taken.



Indicates a major hazard that is most likely to cause irremediable injury or death if the right precautions are not taken.

CONTENTS

INTRODUCTION	2
CONTENTS	3
SPECIFICATIONS	3
LOADING CAPACITY	3
CHECK LIST	3
SAFETY RULES	4
DIFFERENT PARTS OF TRANSPORTER (LS280).....	6
DIFFERENT PARTS OF TRANSPORTER (LS360).....	7
DIFFERENT PARTS OF TRANSPORTER (LS461).....	8
SAFETY INSTRUCTION STICKERS	9
CONTROLS	10
OPERATION	12
MAINTENANCE OPERATIONS TO BE CARRIED OUT BY THE USER	15
LIST FOR REGULAR SELF-INSPECTION	22
EC CONFORMITY DECLARATION	26
MEASUREMENT OF VIBRATIONS	26
EC CONFORMITY DECLARATION	27
MEASUREMENT OF VIBRATIONS	27
EC CONFORMITY DECLARATION	28
MEASUREMENT OF VIBRATIONS	28
EC CONFORMITY DECLARATION	29
MEASUREMENT OF VIBRATIONS	29
TIGHTENING TORQUE (daNm)	30
LIMITED WARRANTY	30
NOTES.....	31

SPECIFICATIONS

Model	LS280	LS360		LS461
Engine	FJ100	GB130	GX120	GX160
Transmission	Belts			
Forward speed (km/h)	1st : 1,5 2nd : 3,4			
Reverse speed (km/h)	1,5	1st : 1,5 2nd : 3,4		
Weight (kg)	140	135	135	165
Fuel tank capacity (L)	2.8	2.5	2.0	3.1

LOADING CAPACITY

Do not carry over the below MAX Loading Capacity

Model	LS280	LS360	LS461
On flat place (Slope less than 5 degree)	250 kg (incl. operator)	350kg	450kg
On slope (Slope between 5~20 degree)	125kg	170kg	200kg

CHECK LIST

INSTRUCTIONS TO THE DEALER

- The assembling, the installation and the first application of the machine is under the OREC dealer's

responsability.

- Read the instruction manual as well as the safety measures. Check that all the before delivery and at delivery check points specified in the following lists have been verified and possibly modified before delivering the machine to its owner.

CHECKS BEFORE DELIVERY

- Check that all the shields, grids and safety guards are in place and in a good state.
- Check that the hydraulic hoses are in place and in a good state. Replace them if necessary.
- Check that there is no oil leak, repair if necessary.
- Check that the safety instruction stickers are in place and in a good state. Replace them if necessary.
- Check that all the bolts and screws are properly tightened with the right torque (refer to page 16).
- Protect the grease nipples by coating them with grease and lubricate the machine.
- Check that the machine can work properly.
Especially Braking system ,Driving system is important to check.

CHECKS ON DELIVERY

- Show the user how to perform the adjustments.
- Explain to the user the importance of the lubrication and show him the different greasing points on the machine.
- Show him the safety devices, grids, guards and the optional equipments.
- Give the instruction manual to the customer, ask him to read it carefully.

SAFETY RULES



CAUTION

Some of the illustrations show the machine with no guard, no shield. Never use the machine without these devices.

- Learn to stop the machine in case emergency.
- Read this manual.
- Do not let anybody use the machine before having read and understood this manual.
- Do not let children use the machine.
- Do not wear loose clothes. They might be grasped by moving parts.
- Always wear protection equipments for when using the machine.
- Only work during daylight or with a good artificial light.
- Check that the safety instruction stickers are in place and in a good condition.
- Keep the machine free from debris or mud.
- Check that the machine can work properly before any use.
- Check that all the shields, grids and safety guards are in place and in a good state.
- It is strictly forbidden to carry persons or animals onto the machine during the work or during the transportation.
- Never stop or start roughly when working on a slope. Never use the machine to work on a stepping terrain.



- Reduce the ground speed when driving on a slope and when turning straight in order to prevent from any risk of losing control.
- Be very careful when bordering ditches.
- Stop the engine, and remove the sparking plug ignition cover before any intervention on the machine.
- Never work under the machine or its parts when lifted, unless they are blocked and maintained into position with sufficient security.
- When driving on a slope, always work going up or down but never across the slope.

- Stay clear of unsteady embankments, holes or rocks. They might be dangerous during work or transport.
- Keep away from electric wires and obstacles. A contact with electric wires cause electrocution and death.
- Stop the machine progressively when lifting or lowering the machine.
- When stopping the work, stop the engine and remove the sparking plug ignition cover before leaving the mower.
- Engage all the safety equipments.
Move the controls only when correctly sat down in the mower
- Visually check hydraulic leaks and if some parts are faulty or missing. Repair before use.
Never change the adjustment of the regulator, it is set in the factory. Unsetting the regulator would cause failures.
- Ensure that the user of the machine has already read and understood this manual and that he is aware of all the safety instructions before any use.
- Always use a chuck and bronze hammer when replacing or intervening on the pins and bolts at the end of rams, rod ... etc in order to avoid the projection of metal fragments.

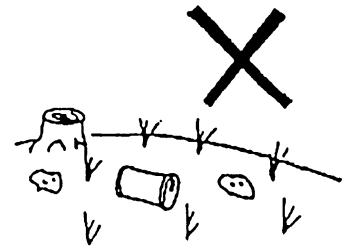

DIFFERENT PARTS OF TRANSPORTER (LS280)

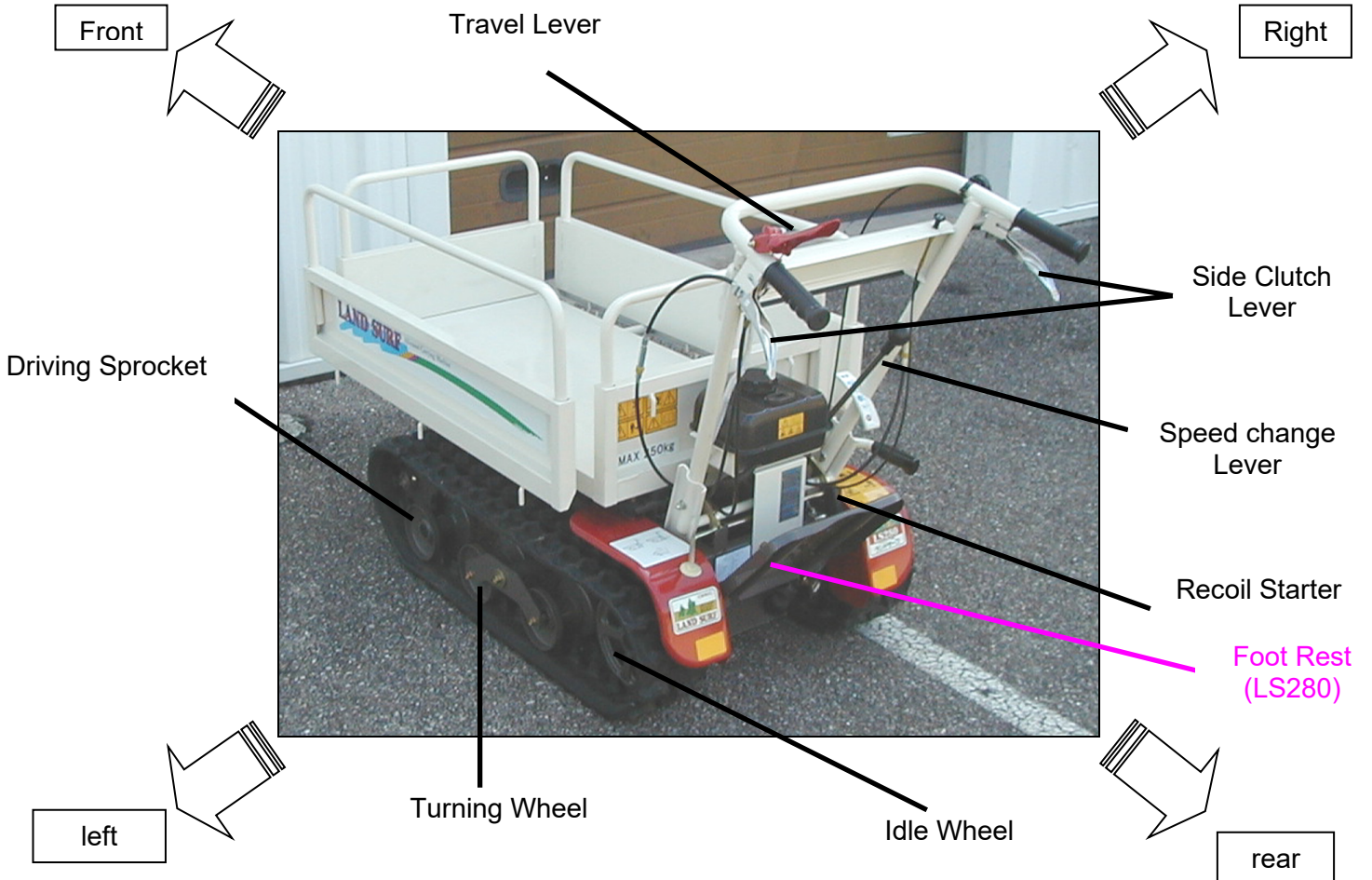

DIFFERENT PARTS OF TRANSPORTER (LS360)

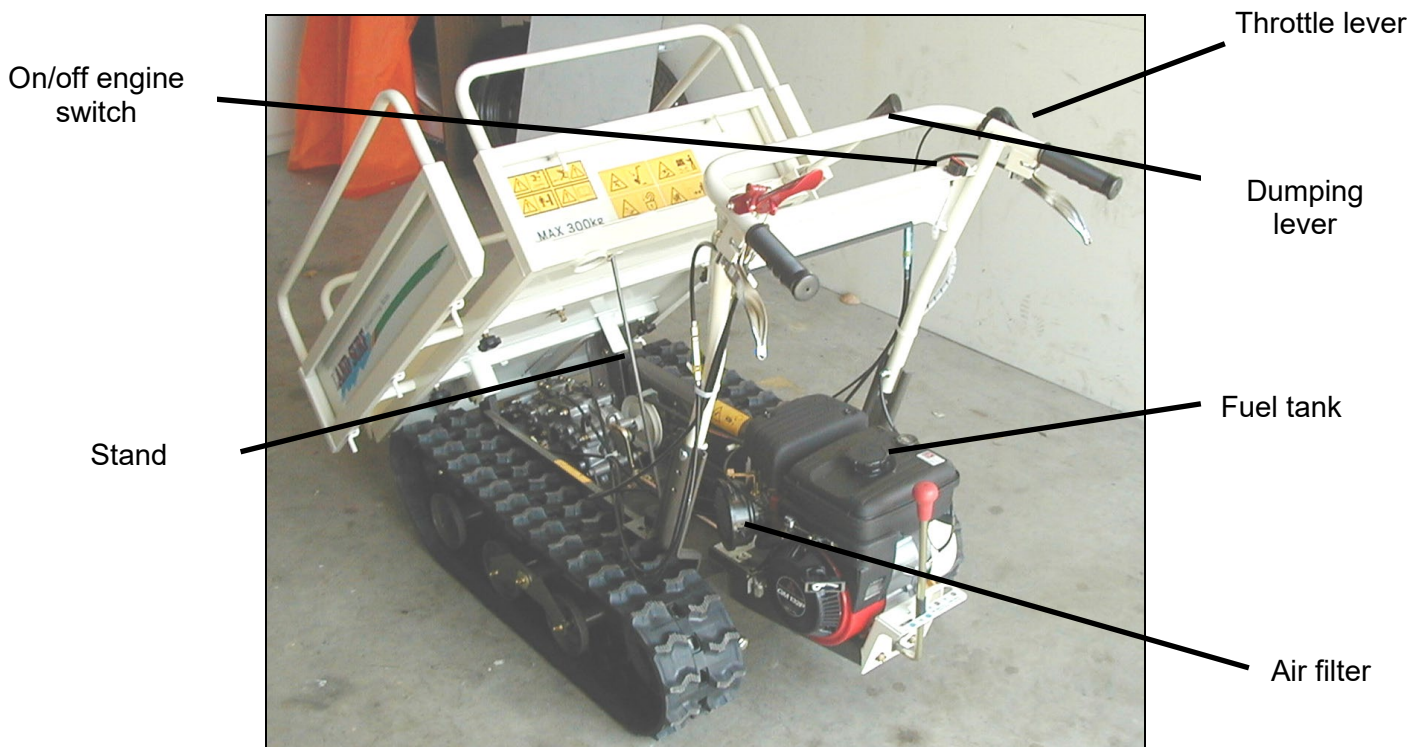
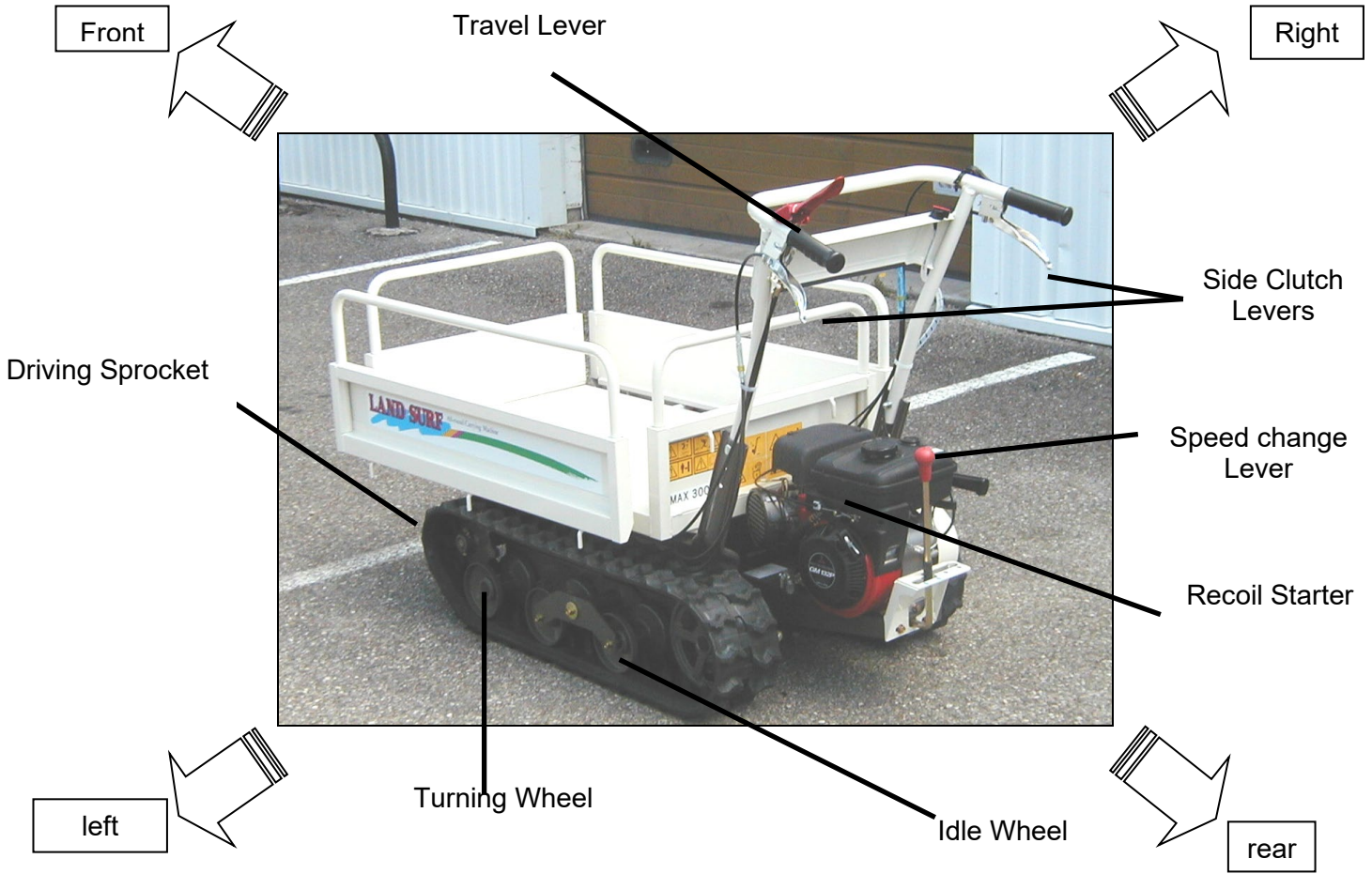

DIFFERENT PARTS OF TRANSPORTER (LS461)

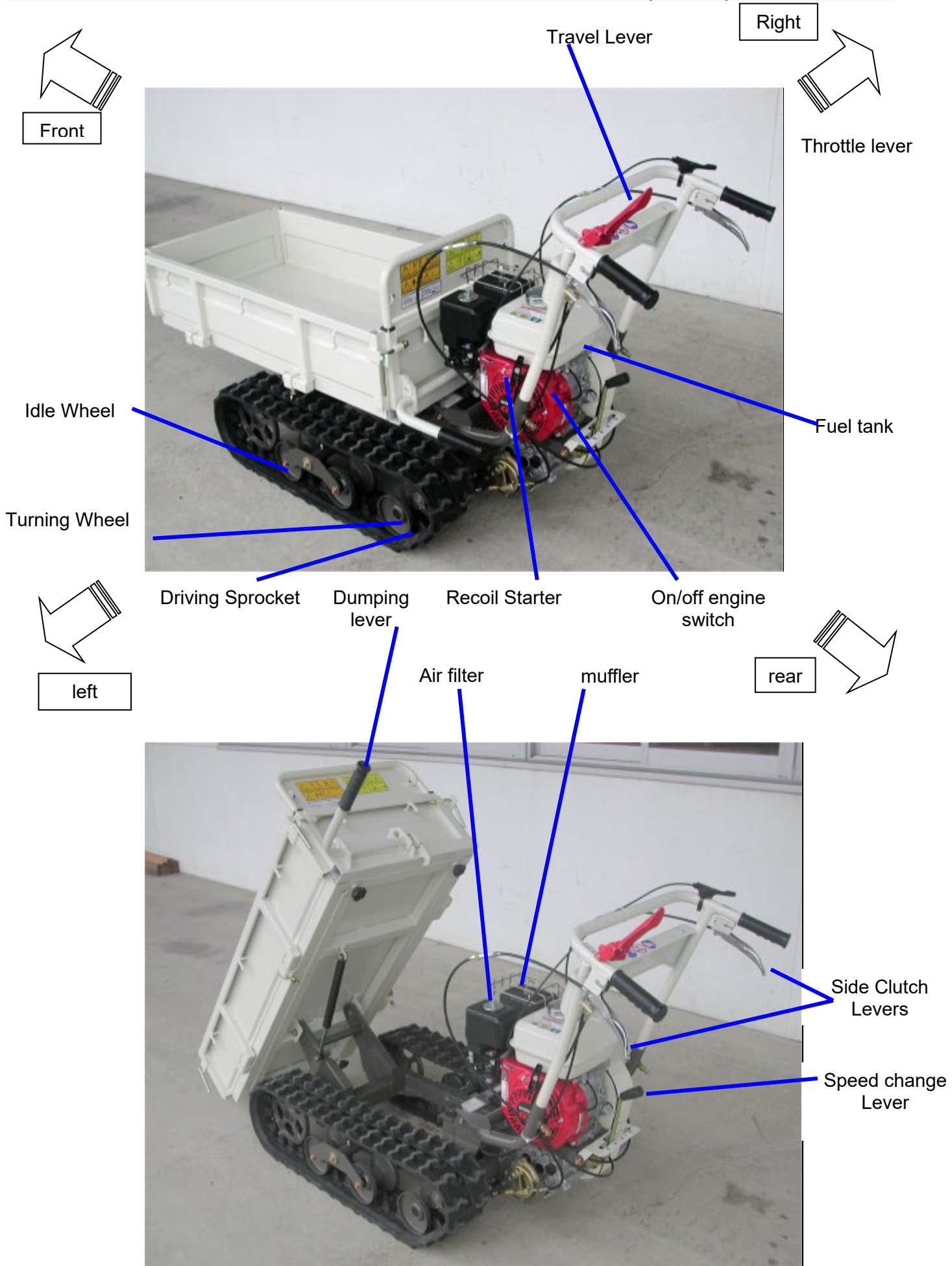

SAFETY INSTRUCTION STICKERS

Note their location and replace them immediately in case of damage or when missing

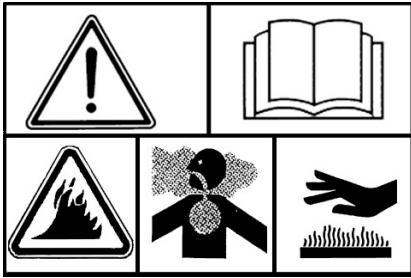

Beware of hot surfaces exhaust gases and burnt read owner's manual



Before doing maintenance remove the spark plug



read owner's manual



Stand clear of the machine



Beware of the rotating parts under the shield.

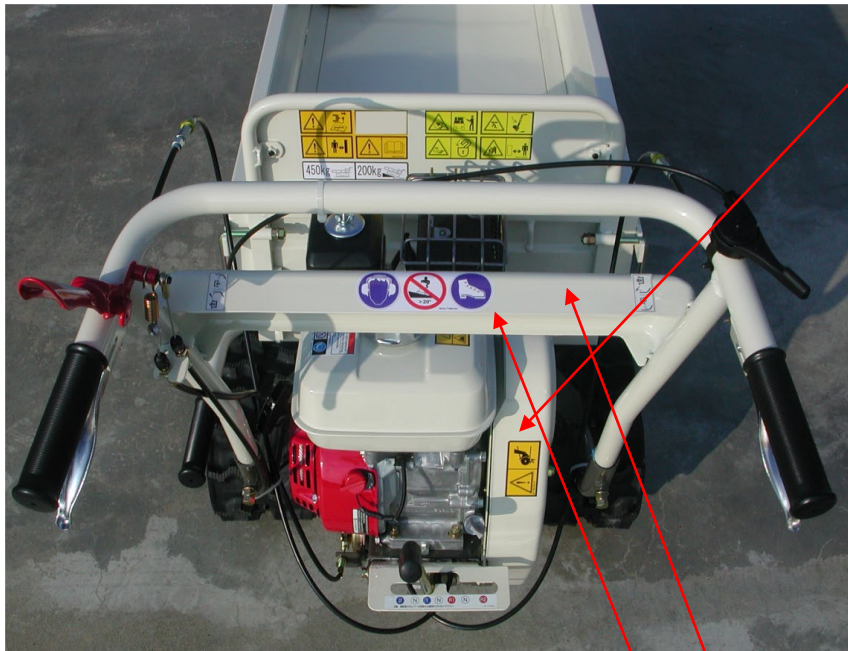

Do not load in height



Always use the stand to secure the folded bucket



- Always wear protective equipment.
- Do not operate in slope more than 20°
- Always wear safety shoes during the operation



Do not change of gear on slopes



Pay Attention for Backgear



(only LS280)
Do not Ride on the Slope operation

CONTROLS

Travel lever(A, figure1)

This lever transmits the power from the engine to the transmission. Grip the lever with the handlebar and it will be in "driving" position. Release the handlebar and it will be in "stop" position.

The driving clutch lever is connected with the brake. When the lever is in "stop" position, the parking brake is led to "on" condition.

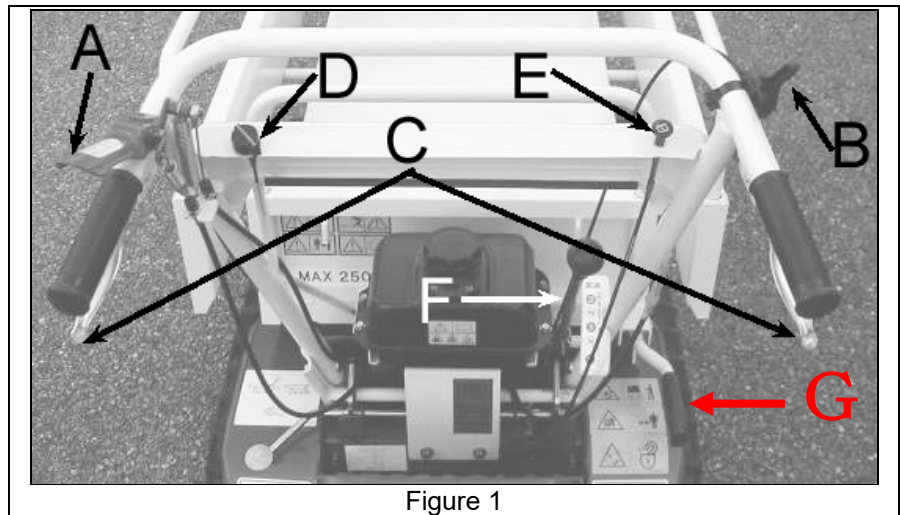

Figure 1



WARNING

Do not fix the driving clutch lever with wires or strings or straps, which is very dangerous.

Speed lever (F, figure1)

This lever decides the speed of the machine. There are two steps for driving forward ("1" & "2") and one step for driving backward ("R"). Before changing speed, shift the driving clutch lever to "stop" position and stop the machine.



WARNING

Only allowed to change travel speed when machine is stopped.

Side Clutch Lever (C, figure1)

It is to change directions of the machine. Grip either lever and the machine turns to that direction. When you grip both levers at the same time, the machine stops on the spot.



WARNING

Handle the side clutch lever with a low speed, or the machine will turn fast, which is very dangerous.

ON/OFF engine switch (D, figure 1)

Turn the switch « ON » to start the engine. Turn the switch « OFF » to stop the engine.

Dumping Lever (G, figure 1)

It is necessary when the platform is dumping. Grip the lever and pull it up.

Choke lever (E figure 1)

Pull the choke knob to start the engine when it is cold. Push the knob when the engine has started.

Throttle lever (Figure 3)

It is to adjust the rotation of the engine.

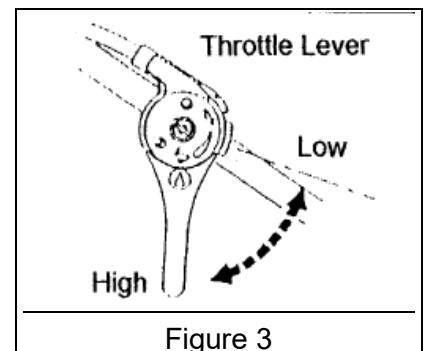

Figure 3

Foot rest pedal(only LS280) (figure 4)

Push the pedal and the handlebar to low down the foot rest. Push the pedal and pull the handlebar to raise the foot rest.



Check that the foot rest is fully locked when raised



Figure 4

OPERATION



DANGER

It is prohibited to overload !



CAUTION

Check the tightening of bolts, referring to the tightening torque chart

The safety was one of our main worry when designing and manufacturing this machine. Therefore, negligence in the use of the machine should reduce our efforts to nothing. The prevention strictly depends on the care and on the skill of the user when applying and maintaining the machine. The best safety method remains a careful and skilled user ; we wish you to be this kind of user.

The user of this machine is responsible for its safe use. He must be a skilled user specially trained for the use of this machine. Read the safety instructions. This machine has been designed to carry to the goods. It is not designed for any other operation. It is not designed to transport other tools or materials that might damage it and cause injuries to the user. It must not be used to carry persons.



DANGER

Never use the machine without having first carried out all the maintenance operations as described in the daily maintenance chapter.



CAUTION

Never let children or unskilled persons use the machine. Check that nobody or no object stands near the machine when at work. They could be hit by the moving parts. Nobody must stand on the machine except the driver. Never put your hands under moving parts.

Starting of the engine

- Engine switch turn to "ON"
- Turn the fuel cock "ON" (Figure 5).
- Check the Speed change lever in neutral position. (Figure 6)
- Set the Choke lever if engine is cold or push throttle lever half if engine is hot.
- Pull the starter rope. When the engine has started, push back the choke lever.(Figure 7)

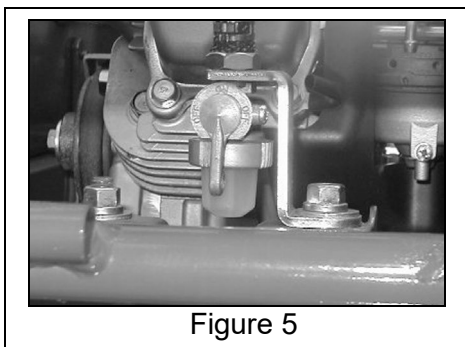
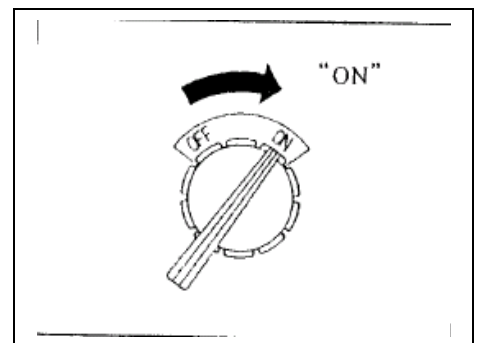

Figure 5

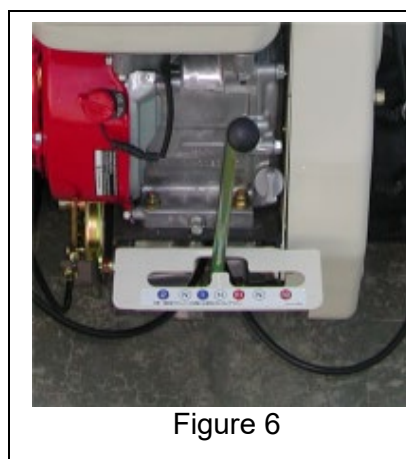

Figure 6

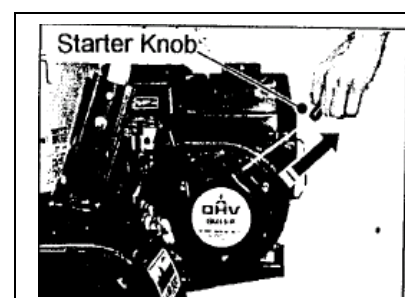

Figure 7



Do not use the choke when the engine is hot.

Make the machine moving

- Select the speed (gear ratio) in accordance with the work to do.(Figure 8)
- Turn the throttle to increase engine speed
- Press slowly the travel lever (Figure 9 A)



Figure 8

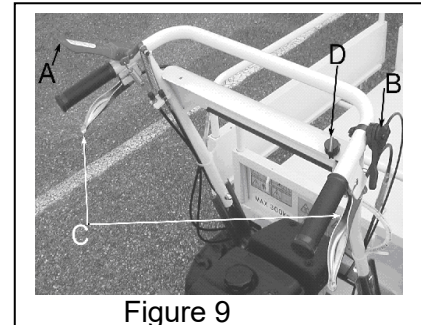
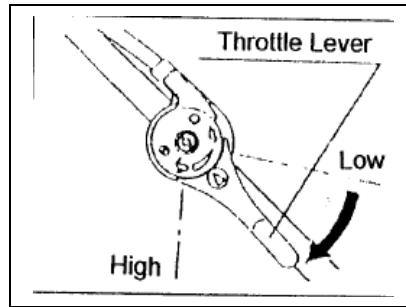

Figure 9

Raising the Loading Box

1. Grip the dumping lever, and lift the loading box forward by hand.
2. Have the safety stand to support the loading box.



Dumping Lever

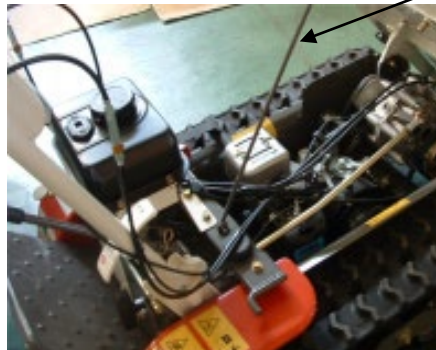

Safety Stand



Lowering the Loading Box

1. Remove the safety stand from the loading box and return it to the frame on the machine.
2. Grip the dumping lever, and push down the loading box backward by hand. When pushed to the bottom, the loading box is locked.
3. Lift the loading box without gripping the dumping lever to check if the loading box is securely "locked".

Dumping

The engine is loaded under the loading box (LS280) or behind the machine (LS360, LS461). Before starting the engine, take care of following points.

WARNING

- Remove the load from the loading box before dumping. Otherwise, the machine is heavier to handle, and the load or the machine may turn over, losing balance.
- When raising the loading box to check the underside, let the stand support the loading box so that loading box may not fall down.
- Before dumping, pay attention to your surroundings.
- Avoid dumping on the slope, where the machine tends to lose its balance as the loading box goes up.
- Dump slowly not to give shocks on the machine.
- Always stop engine before fold the bucket or dump the load.

! WARNING

If the loading box is unlocked on the slope or when the load is clustered on the front side the loading box may suddenly start dumping.

How to stop the machine

- Release the travel clutch lever. (Figure 10)
- Pull back the throttle lever to idle position.
- Stop the engine.
- Turn the Fuel cock off position

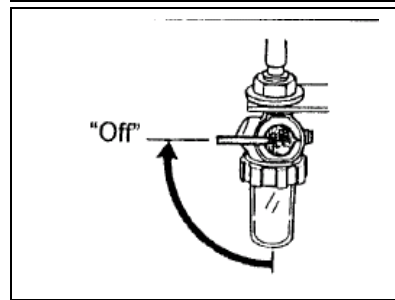
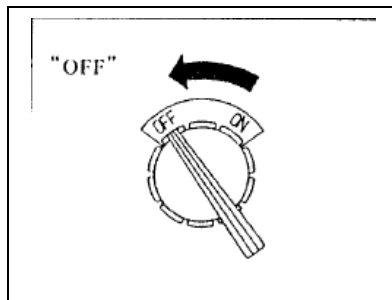
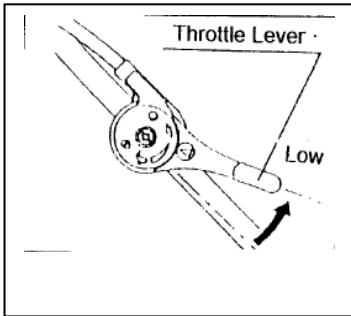
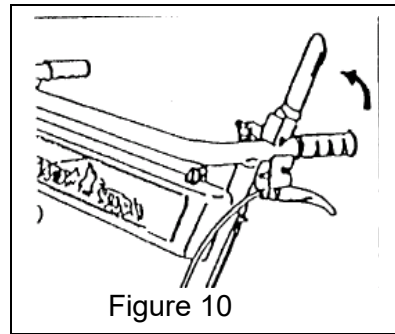

! WARNING

Never park the machine on slopes. Stop it on a level and flat surface.

Storing the machine

Thoroughly clean the machine. Use touch up paint to prevent rust. Check for worn and damage parts, install new parts as required. Perform the normal maintenance of the machine according to maintenance chart. Store the machine in a dry protected area. Remove sparking ignition wire from the sparking plug.

Loading/unloading

Do not ride on the foot rest when loading or unloading the lorry with the machine or on the slope. Ride only on the level ground.

! WARNING

Drive the machine on foot with a low speed when loading or unloading the lorry with the machine or on the slope.

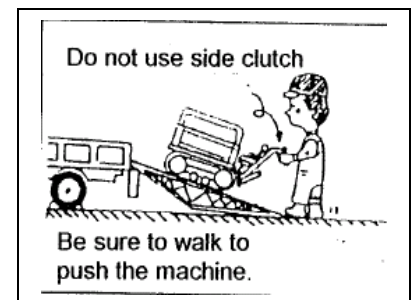

! CAUTION

After unlocking the handlebars, move the handlebars securely to the position for "riding on foot rest" or "walking" and lock the handlebars with the handle lock pedal. (LS280)

MAINTENANCE OPERATIONS TO BE CARRIED OUT BY THE USER



CAUTION

Although oil is filled when the machine is shipped, check if designated amount of oil is filled in designated places before using the machine. Exchange oil regularly to keep the machine in good condition. When inspecting, exchanging, or refuelling oil, put the machine on the large flat ground. Stop the engine after idling, and wait until each part is cooled down (at least 5 minutes).

If starting immediately after stopping the engine: each part of the engine is still hot and dangerous.

Immediately after the engine stops, precise amount of oil cannot be measured as oil still remains in each part of the transmission. Dispose the old oil properly after exchanging.

DAILY MAINTENANCE

Engine oil ("SAE 10W30" or "API SL class")

(LS280: 0.45L, LS360 GX120: 0.56L, LS360 GB130: 0.50L, LS461 : 0.58L.)

Refer to the engine owner's manual delivered with the machine. Check the oil level on the dipstick (A, figure11,12).

Engine oil replacement frequency.

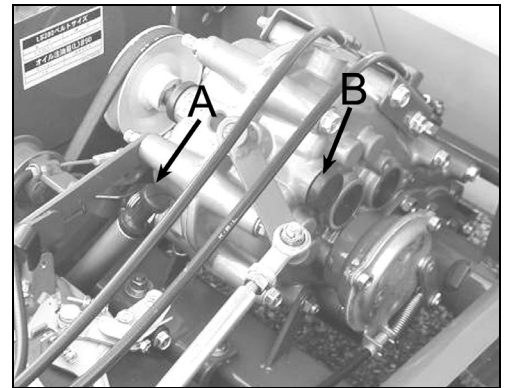

Figure 11(LS280)

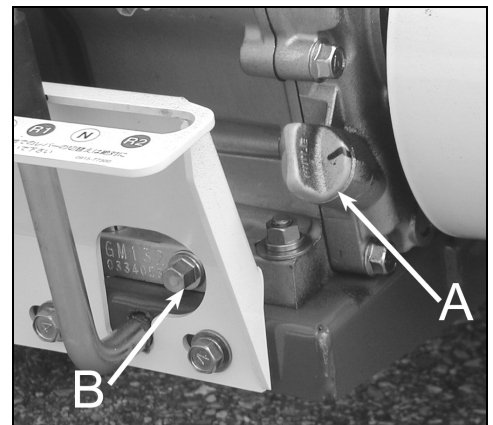

Figure 12 (LS360, 461)

Model	First	Later
LS280	After 8 hours of operation	Each 50hours or Every 1 year whichever comes first
LS360(GX120)	After 20 hours of operation	Each 100hours or Every 1 year whichever comes first
LS360(GB130)	After 25 hours of operation	Each 50hours or Every 1 year whichever comes first

Transmission Oil (1.60L)

1. Raise the Loading Box.
2. Remove the oiling cork (B figure11) at the upside of the transmission case.
3. Add "SAE 90" or "API GL-5" OIL if the level doesn't reach the filling hole.
4. Attach the oiling corks securely on both sides.
5. Lower the Loading Box.

Transmission oil replacement frequency.

First	Later
After 50 hours of operation	Each 100hours or Every 1 year whichever comes first

Fuel

Check the fuel level by the gauge (A figure 13). Check tank level is full before start to work. Check that tank plug is fully closed, and check for leaks. Use only a good quality unleaded gasoline.



DANGER

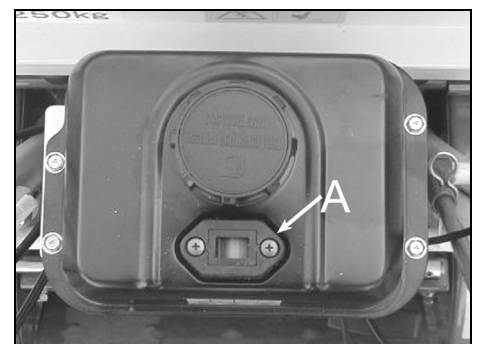

Figure 13

Check fuel tank is closed, wipe fuel spillages before start the machine. Check there is no fire, electric sparks, cigarettes near the machine when refuelling.

Cleaning Fuel Filter Pot



Never work with smoke or under bare illumination.

Clean inside the fuel cock every 50 using hours.

Choose a clean place free of dust.

1. Turn the fuel cock to "close (off)" position.
2. Detach the fuel filter pot, clean the filter with non-flammable solvent such as kerosene to wash away sediment (dust and water), and dry it with air.
3. Attach them securely as they were before.

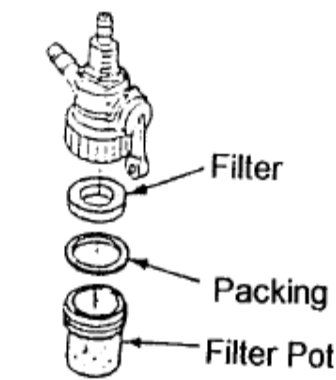

Fuel filter Figure 14



Do not use inflammable oil such as gasoline and thinner.

Other Inspection

1. Check if each handling lever works properly. (Each time before starting the engine.)
 2. Stretch the V belt after a few driving hours, as it tends to be loose at first. (Refer to "Driving Clutch Wire".)
 3. Move the machine a little to check unusual sound and heat.
 4. Avoid working too hard for a first few hours to adjust each part of the machine.
 5. Do not forget to service after working and check the machine regularly. (Refer to "List for Regular Self-Inspection".)
 6. Check if the bolts and nuts are not loosened or fallen.
 7. Check the entire machine to see if the oil is not leaking.
- If the oil is leaking, consult the dealer where you purchased the machine. Do not keep using the machine with the leaking oil, or it may cause an accident and damage the machine.

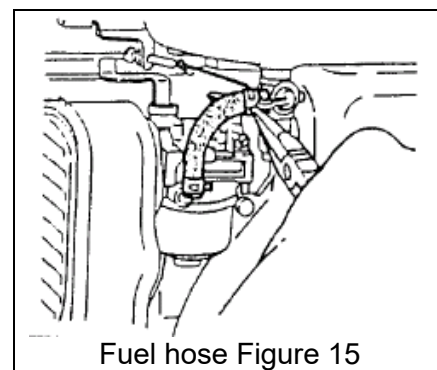

MONTHLY MAINTENANCE

Inspecting Fuel Pipe

The rubbers such as the fuel pipe deteriorate even if unused. Exchange them together with the fastening band every 3 years or when damaged. Keep checking if the pipes and the fastening band are loosened or damaged.

Tips; when exchanging the pipes are careful not to let dust go into the pipes.

Draining transmission oil

- Prepare a proper vessel for receiving the oil.
- Detach the drain plug (A, figure 16) at the underside of the transmission case and drain the oil.

Tips: Detach the oiling cork as well, and the oil can be drained easily.

- Attach the drain plug tightly and supply 1.60L of the transmission oil (SAE 90 or API GL-5).

Transmission oil replacement frequency.



Figure 16

First	Later
After 50 hours of operation	Each 100hours or Every 1 year whichever comes first



Do not throw used oil.

Draining Engine oil

- Prepare a proper vessel for receiving the oil.
- Detach the drain plug (A, figure 17) at the bottom of Engine
Tips: Detach the oiling cork as well, and the oil can be drained easily.
- Attach the drain plug tightly.

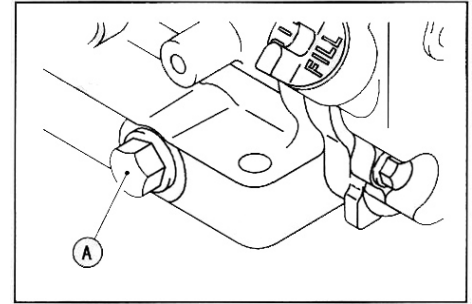

Figure 17

Engine oil replacement frequency:

Model	First	Later
LS280	After 8 hours of operation	Each 50hours or Every 1 year whichever comes first
LS360(GX120)	After 20 hours of operation	Each 100hours or Every 1 year whichever comes first
LS360(GB130)	After 25 hours of operation	Each 50hours or Every 1 year whichever comes first

Air Filter (Figure 18)



CAUTION

If the air cleaner is choked, it may cause the shortage of output and the waste of fuel as well as fire. Make sure to clean it regularly. If you drive the machine without the air cleaner, the machine will absorb dust and damage the engine

1. Remove the cover (A).
Detach the element carefully not to let dust go into the Carburetor.
2. Wash the foam element with neutral detergent, wring it tight and dry it.
3. Soak it in the new engine oil (SAE10W-30 or equivalent) and wring it tight to drop off extra oil.
4. Tap the paper element or wipe the inside to remove dust.
5. Wipe off stain inside the case with a waste cloth and attach each element as it was before.

When washing, do not pull or rub the element strongly because it will be broken.

When tapping the paper element, be careful not to hurt the filter paper.

Do not rub the filter paper with a brush.

A hot wind may damage the connecting part of the paper element. Dry it with a cooler wind.

Cleaning and Exchange of Air Cleaner

Model	Type	Cleaning	Replace
LS280(FJ100)	Paper Element	Every 50 Hours	Every 200 Hours
LS360(GB130)	Foam Element	Every 25 Hours	Every 100 Hours
LS360(GX120)			
LS461(GX160)			

When using the machine in a dusty place, try to clean it frequently.

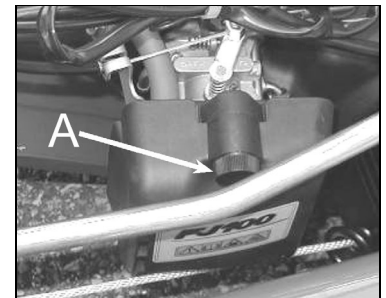

Figure 18(1)(LS280)



Figure 18(2)(LS360)

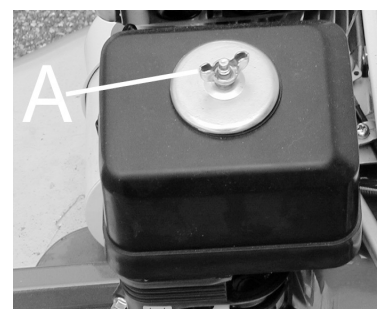
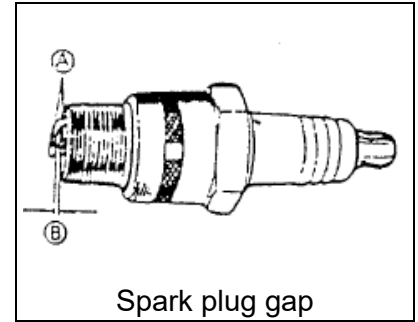

Figure 18(3)(LS461)

Inspecting and Adjusting Ignition Plug

Inspecting and Cleaning

1. Detach the ignition plug cap.
2. Detach the ignition plug with the plug wrench.
3. If the carbon sticks to the electrodes, remove it with the wire brush. Wipe off moisture.
4. If a crack is noticed at the ceramic part or the electrodes are worn out, exchange the ignition plug with new one.



Adjusting

5. After rubbing the both electrodes with sandpaper, adjust the gap between the electrodes.
Standard Gap: 0.6 - 0.7 mm.
6. Attach the ignition plug.

Tips:

When fastening, wrench with your hand before using the plug wrench.
If fastening with the plug wrench from the beginning, be careful not to crush the screw head.

Oiling, Moving Parts

Be sure to lubricate them with the engine oil (#30) every 30 hours.

Otherwise, rust or overheat makes the machine heavy to handle. It may also cause damage.

Fulcrum of Side Clutch Wire, Lever & Clutch Lever (A, figure 19)

Fulcrum of travel Tension Arm (figure 20, see A)

Fulcrum of Dump (figure 21, see A)

Fulcrum of Change Lever (figure 22, see A)

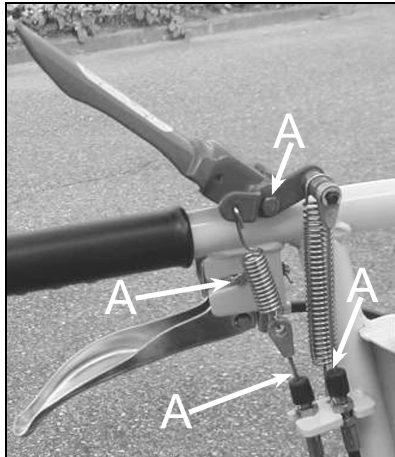

Figure 19

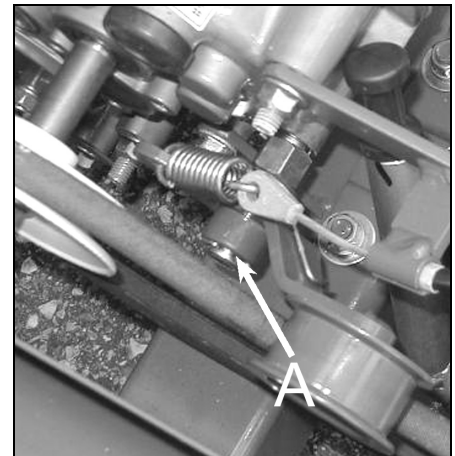

Figure 20

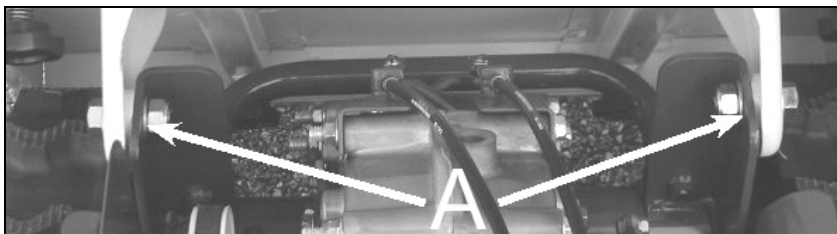

Figure 21

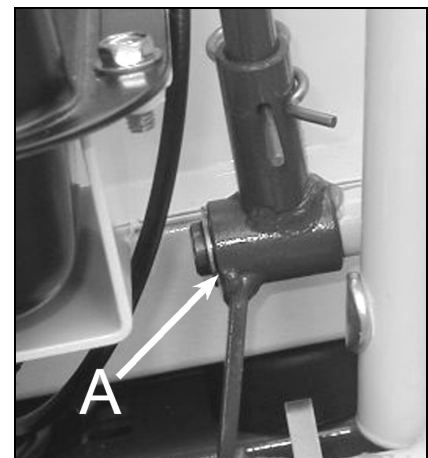

Figure 22

Driving Clutch Wire (A, figure 23)

1. Release the driving clutch lever to "stop" the machine. Let the running clutch lever free.
2. Loosen the lock nut on the running clutch wire.
3. Turn the adjusting nut and adjust the tension of the running clutch wire.
If the V belt slips with the load even if you shift the driving clutch lever to "on" position adjust the adjusting nut up.
When the running clutch does not function well adjust the adjusting nut to down.
4. Fasten the lock nut tightly after adjusting.

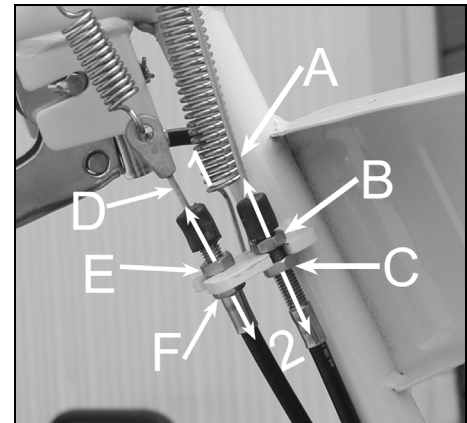

Figure 23

Brake Wire (D, figure 23)

1. Grip the running clutch lever and shift it to "running" position. Let the brake wire free.
2. Loosen the lock nut on the brake wire. (E, figure 20)
3. Turn the adjust nut (F, figure 20) and adjust the tension of the brake wire as follow : Turn the adjusting nut up direction if the brake is loose, in opposite direction if too tight.
4. Fasten the lock nut tightly after adjusting.

Side Clutch Wire

Tips;

When the side clutch lever does not work enough because of the play or the lever does not turn smoothly, adjust it with the middle adjuster of the side clutch wire.

1. Loosen the lock nut (A, figure 24) at the middle adjuster of the side clutch wire.
2. Turn the adjust nut to adjust the tension of the side clutch wire. (B, figure 24)

When the side clutch lever does not return smoothly adjust the adjust nut to up direction.

When the side clutch lever does not work well adjust the adjust nut to down direction.

3. After adjusting, fasten the lock nut tightly. Adjust the adjust nut so that the play at the edge of the side clutch lever is 2-5 mm.

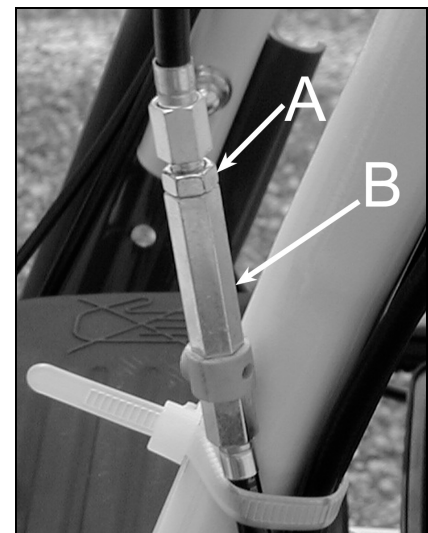

Figure 24

Inspecting Driving V Belt

1. Let the platform dump. (Refer to, "Dumping".)
2. Check if the running V belt is not damaged.
When it is damaged, exchange it with the new one. (Refer to "Adjusting Belt Holder")
3. Return the platform to its original position.

Tips : The running V belt wears out. Keep checking its condition and exchange the belt when something is wrong with it. Time for adjusting is as follows.

Size of Running V Belt	SA32 x 1(LS280) LA74 x 1(LS360) LB31 x 1(LS461)
Time for Adjusting	First Time: After a Few Hours Later: Every 50 Driving Hours

Adjusting Belt Holder

Tips;

The ill-adjusted belt holder as well as wire may hinder the function of the running clutch. After removing the belt holder to exchange the V belt, adjust the belt holder as follows.

1. Let the platform dump.
2. Shift the running clutch lever to "running" position and adjust the position of the belt holder so that the gaps on both sides between the running V belt and the belt holder are 2-3 mm.(A figure 25)
3. Return the platform to its original position.

Tips:

The belt holder should occupy about one third of the engine pulley. When the running clutch lever is in "stop" position, hold the belt a bit to raise it slightly above the groove of the engine pulley.

Adjusting Tension of Crawler

The crawler tends to extend when it is brand-new, then loosened as it sticks to the sprocket with time. As the ill-adjusted tension of the crawler may let the wheels off the machine or significantly shorten the crawler's life, adjust its tension as follows.

1. Raise the machine flatly against the ground with a jack.



WARNING

Fix the jack tightly so as not to fall down during operation.

2. Loosen the lock nut on the crawler tension bolt at the back.(A figure 26)
3. Turn the crawler tension bolt to adjust the gap A between the crawler and the turning wheel to 8 mm. (Figure 27)
4. After adjusting, fasten the lock nut tightly.
5. Lower the machine.

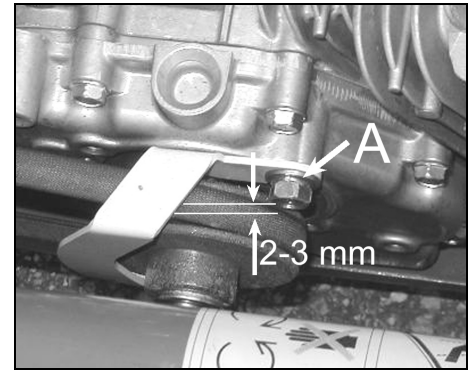

Figure 25

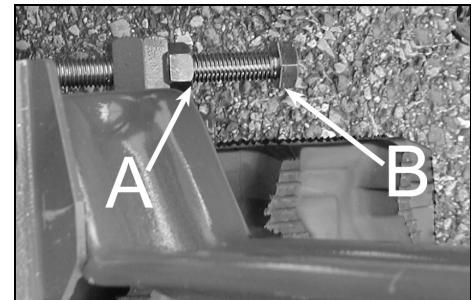

Figure 26

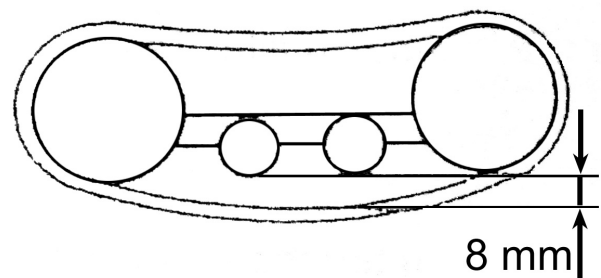

Figure 27

Safekeeping for a Long Time



Danger

Stop the engine. When draining the gasoline, choose a well-ventilated place and keep away smoke or bare illumination. Be careful to handle the drained gas.

Store the machine in a solid level place.

When draining the gasoline in the tank or covering the machine, wait until the engine and muffler are cooled down.

1. When not using the machine more than 30 days, drain the gas inside the carburetor and the fuel tank. Otherwise, changed gas may cause trouble.
When draining the fuel in the tank, remove the fuel filter pot, attach the vessel as the receiver and shift the fuel cock to "on (open)" position.
When draining the fuel in the carburetor, detach the fastening bolt at the underside.
2. Remove dirt and foreign substance at the machine and crawler.
When washing, protect electricity on the engine, carburetor, air cleaner and drain of muffler with covers to avoid engine trouble.
3. Clean the engine and outside of the machine with an oiled clothe.
4. Exchange the engine oil.
5. Clean each parts sufficiently, especially the recoil starter, air cleaner, and muffler and carburetor.
Remove weeds or dust inside the belt cover with an air spray. Remove rust and put anti-rust paint.
If working without removing weeds or dust, they may choke the engine and cause a burn or a fire.
6. Lubricate each place and repair the machine if necessary.

7. Shift the running clutch lever to "Stop (underside)" position.
8. Store the machine in a well-ventilated dry place with a roof.
9. Cover the machine to prevent dust.

Care in Cold Places

In winter, be sure to remove dirt and foreign substance adhering to the machine, which may freeze and cause trouble. Park the machine on the concrete road, solid dry road or square pieces of timber.

If freezing dirt at the machine hinders smooth operation, do not try to drive by force. Pour hot water on that part or wait till it melts.

(OREC is not responsible for the damage caused by forced driving.)

Detailed Statement of Bag for Tools

No.	Name	Model/ Size	Qty.	Note
1	Instruction Manual		1	
2	E/G Manual		1	
3	Tools for Engine	Attachment of Engine	1	12mm plug wrench (LS280)
			1	21mm plug wrench(LS360, LS461)
4	Double Ended Spanner	10 x 12	1	
		14 X 17	1	
		19 X 22	1	

Detailed Statement of Articles for Consumption

No.	Parts Name	Parts Number	Qty.	Note
1	V Belt	89-6122-003200	1	SA32 (LS280)
		89-6122-007401	1	LA74 (LS360)
		89-6123-003100	1	LB31 (LS461)
2	Brake Wire	80-1920-A07-00	1	(LS280, LS360)
		0919-70100	1	(LS461)
3	Choke Wire	0914-70100	1	(LS280)
4	Running Clutch Wire	80-1920-A06-00	1	(LS280)
		80-1923-961-00	1	(LS360)
		0919-70200	1	(LS461)
5	Side Clutch Wire	80-1920-962-00	2	
6	Throttle Wire	0914-75100	1	
7	Rubber Crawler	80-1920-401-00	2	160W x60P x 35L
8	Fuel Hose	92192-2105	1	4x8x300(E/G parts) (LS280)
	Braid Tube	705A061000		(E/G parts) (LS280)

LIST FOR REGULAR SELF-INSPECTION

Negligence of inspection and service may cause an accident. To use the machine efficiently and safely, inspect the machine according to the following list.

Do the yearly-check (Y) once a year, monthly-check (M) once a month and daily-check (D) each time you use the machine.

Item		Inspection		Time			
				D	M	Y	
M o t o r	Main Body	1. Start, Noise	Starts easily with normal sound.	o	o	o	
		2. Speed, Acceleration	Rotates normally with acceleration.	o	o	o	
		3. Exhaust, Leak of Gas	Color, smell and sound are normal.	O	O	O	
		4. Slack of Cylinder Head and Each Fastening Part of Manifold	Not recognized. * (Normal fastening torque is not loosened.)			O	
		5. Space of Valve	Is normal.			O	
		6. Pressure	Is normal.			O	
		7. Crack and Deformation of Engine Base. Slack of Bolts and Nuts	Engine Base has no crack and deformation. Bolts and nuts are tight.	O	O	O	
	*	Lubrication Device	1. Amount of Oil, Dirt	Amount is suitable. Oil is not dirty, no water or metal is in it.	O	O	O
			2. Leak of Oil	Oil is not leaking from oil seal or gasket.	O	O	O
	*	Fuel Device	1. Leak of Fuel from Fuel Tank or Pipe	Fuel is not leaking.	O	O	O
			2. Choke of Fuelling Filter	Filter is not dirty, deformed or choked		O	O
			3. Quality and Quantity of Fuel	Fuel is enough with good quality.	O	O	O
	*	Electricity Device	1. Slack or Damage of Connecting Parts of Electric Codes	Harness is correctly connected, is not loosened nor damaged.		O	O
			2. Gap between Electrodes of Ignition Plug, Abrasion of Electrodes, Accumulation of Carbon	Electrodes are not badly worn. Carbon is not accumulated. Gap between electrodes is proper			O
	*	Cleaning Device	1. Crack, Deformation and Attachment of Air Cleaner Case	Case is not cracked or deformed and properly attached.		O	O
			2. Damage and Dirt of Element	Element is not dirty, broken or worn out.	O	O	O
	*	Cooling System	1. Choke of Recoil Cover with Mud or Weeds	Recoil cover is not choked with mud or weeds.	O	O	O
			2. Accumulation of Mud or Weeds around Muffler	Mud and Weeds are not accumulated around muffler.	O	O	O
	Trans mission	Running Clutch	Function of Running Clutch	Is smooth	O	O	O
		V Belt	1. Tension of V belt	Is proper.	O	O	O
			2. Damage, Dirt	Is not recognized.		O	O
Transmis sion *		1. Unusual Sound, Heat or Motion	Is not recognized.		O	O	
		2. Amount of Oil, Dirt	Amount is suitable. Oil is not dirty.			O	
	3. Leak of Oil	Oil is not leaking from oil seal or packing Part.	O	O	O		

	Turning Device	1. Function of Side Clutch	Is normal.	0	0	0
Body & Door	Platform & Door	1. Up- and Underside of Platform, Function of Door	Is normal.	0	0	0
		2. Crack, Deformation and Corrosion of Each Part	Is not recognized.	0	0	0
		3. Slack or Drop of Bolts or Nuts	Is not recognized.	0	0	0
	Door Side Frame	-	-			
	Body	1. Crack, Deformation Slack or Drop of Bolts or Nuts	Is not recognized.		0	0
	Safety Stick	1. Attachment of Safety Stick	Stick is not bent or deformed.		0	0
	Lever and Wire	1. Damage, Slack, Abrasion of Levers and Wires Deficit of Split Pins	Attached and function correctly. Damage, slack, abrasion and drop are not recognized.	0	0	0
Running System	Turning Wheel, Idle Wheel, Sprocket	1. Crack, Deformation or Abrasion	Is not recognized.	0	0	0
		2. Unusual Sound or Heat	Is not recognized.	0	0	0
		3. Foreign Substance like Metal or Stone	Foreign substance is not meshed in.	0	0	0
		4. Slack or Drop of Bolts and Nuts	Is not recognized.	0	0	0
		5. Leak of Oil	Is not recognized.	0	0	0
	Crawler	1. Condition of Steel Code	Code is not cut off or damaged.	0	0	0
		2. Deficit, Deterioration or Abrasion of Rubber	Is not recognized.	0	0	0
		3. Tension of Crawler	Is proper.	0	0	0
Tension Bolt	1. Deformation or Corrosion of Crawler Tension Bolt	Is not recognized.		0	0	
Control	Brake	1. Function of Parking Brake	Is normal. (Stops machine without load on slope with inclination of 18 degree.)		0	0
		2. Function of Lever and Wire Deficit of Split Pin	Lever and wire works smoothly. Split pin has no deficit.	0	0	0
	Symbol Mark	1. Damage	Each mark is correctly attached without damage.		0	0

Consult with the shop about *. You are charged a fee.

Causes of Trouble and Measures

If the following phenomena occur, deal with them correctly according to the

Phenomenon	Cause	Measure
Machine does not start. (Running clutch is not in.)	Running clutch wire is not adjusted.	Adjust running clutch wire.
	V belt is worn out or damaged.	Exchange belt.
	Gear is not completely in.	Put in gear completely.
	Parking brake is put on.	Put off parking brake.
	Transmission is in trouble.	Dismantle and repair transmission.
Machine does not stop. (Running clutch is not out.)	Belt holder is not adjusted.	Adjust belt holder.
	Running wire is not adjusted.	Adjust running wire.
Side clutch does not return. (Is not out.)	Side clutch wire is not adjusted.	Adjust side clutch wire.
	Side clutch lever or wire gets rusty.	After inspection, oil or exchange it.
	Nail clutch is worn out or damaged.	Dismantle and repair transmission case.
Unusual sound is noticed from transmission	Transmission oil is lacking or very dirty.	After inspection, refuel or exchange oil.
	Bearing or collar is worn out.	Dismantle and repair transmission case.
	Gear or bearing is damaged or worn out.	Dismantle and repair transmission case.
Gears are not engaged.	Gear is not securely shifted.	Shift gear securely.
	Change rod is bent. Shift gear is worn out.	Repair change rod. Exchange shift gear.
	Load is too heavy	Reduce load to less than movable load.
Gear does not work.	Shift gear is damaged or overheated Bearing is worn out.	Dismantle and repair transmission case.
	Change rod is bent.	Repair or exchange change rod.
Parking brake does not work well.	Parking brake is not adjusted.	Adjust parking brake wire.
	Parking brake wire gets rusty.	After inspection, oil or exchange it
	Brake lining is worn out.	Exchange brake lining.
	Water is in brake drum.	Put on brake several times to dry inside.
	Load is too heavy.	Reduce load to less than movable load.
Machine does not run smoothly.	Load is too heavy.	Reduce load to less than movable load.
	Driving sprocket is worn out or damaged.	Exchange sprocket.
	Turning wheel and idle wheel are damaged.	Exchange turning wheel and idle wheel.
	Crawler is loosened or worn out.	Adjust or exchange crawler.
Crawler drops off.	Crawler is loosened or worn out.	Adjust or exchange crawler.
Unusual heat or intermittent sound is noticed from turning wheel or idle wheel.	Bearing is worn out or damaged.	Exchange bearing.
	Turning wheel and idle wheel or damaged.	Repair or exchange wheels.

Consult with the shop about *. You are charged a fee.

Bad Condition of Engine and How to Deal with It

When the engine is in bad condition, deal with it properly according to the following list.

Phenomenon	Cause	Measure	
Machine does not start (smoothly).	Throttle lever is not in "start" position.	Change throttle lever to "start".	
	Choke lever is not pulled.	When engine is cool, pull choke lever and start.	
	Fuel is not running.		Check fuel tank and remove sediments or moisture.
			Detach filter pot of fuel cock and remove sediments in cup and dust sticking to filter.
	Air or water is mixed in fuel sending system.	Remove foreign substance, and check pulp and fastening band. If they are damaged, exchange or repair them.	
	When it is cold, oil is too sticky and engine does not rotate easily.	Choose proper oil according to temperature.	
	Ignition coil or unit does not work.	Exchange ignition coil or unit.	
Ignition plug is in bad condition.		Check gap between electrodes of plug and adjust it.	
		Exchange plug.	
After idling engine stops.	Ignition coil is damaged.	Exchange ignition coil.	
Output is not Enough.	Cylinder piston ring is worn out.	Exchange cylinder piston ring.	
	Air cleaner is choked.	Clean air cleaner element.	
	Quality of fuel is bad.	Exchange it with better fuel.	
	Choke is not completely open.	Return choke lever to "open" position.	
	Cooling- or air cleaning system is choked.	Clean around recoil cover and air cleaner.	
	V belt is loosened and slips.	Adjust tension of V belt.	
	Throttle wire is not adjusted.	Adjust throttle wire.	
Engine vibrates.	Load is too heavy.	Reduce load.	
	Engine base is deteriorated or cracked.	Repair or exchange engine base.	
	Other reasons.	-	
Engine runs out soon.	Engine oil is leaking	After inspection and repair, refuel it.	
	Cylinder piston ring is worn out.	Exchange cylinder piston ring.	
Fuel runs out soon.	Deterioration of fuel pipe causes fuel leaking.	Exchange fuel pipe.	
	Air cleaner is choked.	Clean or exchange air cleaner.	
Throttle lever does not work well.	Throttle wire is bent or rusty.	Exchange throttles wire.	
	Throttle lever is deformed and does not function well.	Exchange throttle lever.	
Engine stops suddenly.	Fuel is lacking.	Supply fuel.	
	Fuel cock is closed.	Open fuel cock.	
	Engine oil is lacking or deterioration of oil causes overheats.	Refuel engine oil or exchange overheated part.	
Color of exhaust is black.	Quality of fuel is bad.	Exchange it with better fuel.	
	Too much engine oil is supplied.	Reduce oil to normal amount.	
Black smoke comes out of muffler and output is lowered.	Air cleaner element is choked.	Clean air cleaner element.	
	Choke lever is not completely open.	Return choke lever completely to "open" position.	
Blue smoke comes out of muffler.	Too much engine oil is supplied.	Reduce oil to normal amount.	
	Cylinder piston ring is worn out.	Exchange ring.	
Rotation of engine is unstable. (Does not rise.)	Choke lever is not completely open.	Return choke lever completely to "open " position.	
	Quality of fuel is bad.	Exchange it with better fuel.	
	Jet inside vaporizer is choked.	Dismantle and clean vaporizer.	
Engine stops after a while	Ignition coil is damaged.	Exchange ignition coil.	
	Fuel filter is choked.	Clean fuel filter.	
Exhaust has pungent smell.	Quality of fuel is bad.	Exchange it with better fuel.	

Consult with the shop about *. You are charged a fee.

EC CONFORMITY DECLARATION

Business name and full address of the manufacturer : OREC CO LTD
548-22 HIYOSHI HIROKAWA-MACHI
YAME-GUN FUKUOKA JAPAN

Designation : walk behind crawler dumper
Mark : OREC
Type : LS280

Serial Identification :
Engine :
- Manufacturer : Kawasaki
- type : FJ100
- Power : 2,2 kW

Conforms to directives: 2000/14/EC, 2006/42/EC, 2004/108/EC
Conformity assessment : 2006/42/EC Annex VIII
Conformity assessment : 2000/14/EC Annex V
Measured acoustic power level : 89,8 dB(A)
Granted acoustic power level : 90 dB(A)
Acoustic pressure level at operator's ears : 81,2 dB(A)
Harmonized standards used : EN 474-1 part 6-2006, EN ISO 14982-2009,
EN ISO 3744-2010, EN ISO 3746-2010,
EN1032-2003+A1-2008, EN ISO 20643-2008

made at : Fukuoka, 24 August 2016

Signed : Haruhiko Imamura
Function : Managing director



MEASUREMENT OF VIBRATIONS

Mark : OREC Model : LS280
Engine : FJ100

ACCELEROMETER POSITION	Awp
100 mm of the end of handlebar (left side)	1,93 m/s ²
100 mm of the end of handlebar (right side)	1,53 m/s ²

EC CONFORMITY DECLARATION

Business name and full address of the manufacturer :

OREC CO LTD
548-22 HIYOSHI HIROKAWA-MACHI
YAME-GUN FUKUOKA JAPAN
walk behind crawler dumper

Designation :

Mark :

Type :

Serial Identification :

Engine :

- Manufacturer :

- type :

- Power :

Honda

GX120

2,9 kW

Conforms to directives:

2000/14/EC, 2006/42/EC, 2004/108/EC

Conformity assessment :

2006/42/EC Annex VIII

Conformity assessment :

2000/14/EC Annex V

Measured acoustic power level :

94,5 dB(A)

Granted acoustic power level :

95 dB(A)

Acoustic pressure level at operator's ears :

88 dB(A)

Harmonized standards used :

EN 474-1 part 6-2006, EN ISO 14982-2009,
EN ISO 3744-2010, EN ISO 3746-2010,
EN1032-2003+A1-2008, EN ISO 20643-2008

made at : Fukuoka, 24 August 2016

Signed : Haruhiko Imamura
Function : Managing director



MEASUREMENT OF VIBRATIONS

Mark : OREC

Model : LS360

Engine : GX120

ACCELEROMETER POSITION	Awp
100 mm of the end of handlebar (left side)	3,53 m/s ²
100 mm of the end of handlebar (right side)	3,66 m/s ²

EC CONFORMITY DECLARATION

Business name and full address of the manufacturer :

OREC CO LTD
548-22 HIYOSHI HIROKAWA-MACHI
YAME-GUN FUKUOKA JAPAN
walk behind crawler dumper

Designation :

Mark :

Type :

Serial Identification :

Engine :

- Manufacturer :

- type :

- Power :

Honda

GX160

3,9kW

Conforms to directives:

Conformity assessment :

Conformity assessment :

Measured acoustic power level :

Granted acoustic power level :

Acoustic pressure level at operator's ears :

Harmonized standards used :

2000/14/EC, 2006/42/EC, 2004/108/EC

2006/42/EC Annex VIII

2000/14/EC Annex V

98 dB(A)

98 dB(A)

89,8 dB(A)

EN 474-1 part 6-2006, EN ISO 14982-2009,

EN ISO 3744-2010, EN ISO 3746-2010,

EN1032-2003+A1-2008, EN ISO 20643-2008

made at : Fukuoka, 24 August 2016

Signed : Haruhiko Imamura

Function : Managing director



MEASUREMENT OF VIBRATIONS

Mark : OREC

Model : LS461

Engine : GX160

ACCELEROMETER POSITION	Awp
100 mm of the end of handlebar (left side)	5,08 m/s ²
100 mm of the end of handlebar (right side)	4,89 m/s ²

TIGHTENING TORQUE (daNm)

Use the chart below to tighten screws, bolts and nuts without other specifications

DIAMETER of The screw (mm)	Tightening torque following the marks on the screw head				
	4 Or without mark	7	8	9	11
3	0,3 to 0,5	---	---	---	---
4	0,8 to 1,0	---	---	---	---
5	2,5 to 3,4	5,4 to 6,4	6,4 to 7,4	6,4 to 7,4	8,8 to 9,8
6	4,9 to 6,9	9,8 to 11,8	11,8 to 13,7	11,8 to 13,7	14,7 to 16,7
8	11,8 to 16,7	24,5 to 29,4	29,4 to 34,3	34,3 to 36,2	36,3 to 41,2
10	20,6 to 29,4	39,2 to 44,1	49 to 53,9	49 to 53,9	72,6 to 82,4
12	44,1 to 53,9	83,4 to 93,2	93,2 to 107,9	93,2 to 107,9	122,6 to 137,3
14	63,7 to 78,5	117,7 to 132,4	132,4 to 147,1	147,1 to 166,7	205,9 to 225,6
16	88,3 to 107,9	152 to 171,6	176,5 to 196,1	215,8 to 245,2	313,8 to 343,2
18	117,7 to 137,3	205,9 to 235,4	245,2 to 274,6	313,8 to 343,2	441,3 to 470,7
20	147,1 to 166,71	235,4 to 274,6	313,8 to 353	441,3 to 480,5	617,8 to 657,1
22	176,5 to 205,9	421,7 to 451,1	539,4 to 578,6	608 to 647,2	843,4 to 882,6
24	235,4 to 264,8	539,4 to 568,8	706,1 to 745,3	784,5 to 823,8	1098,4 to 1137,6

LIMITED WARRANTY

Each new product manufactured by OREC is guaranteed under the cope of the following terms. The warranty applies to defective parts due to defect in assembling and construction or/and in material imputable to us. It is valid for a period of one year and for normal use of the machine. It does not apply to engines manufactured by other companies that also guarantee their materials and whose guarantee is supplied with the machine.

1° This guarantee is limited to the sole replacement of the defective parts during one year commencing with the purchasing date of the machine. The guarantee is limited to the parts that are previously shown to and acknowledged by OREC.

2° Each part concerned by a guarantee claim must be returned to OREC's in order to be inspected, repaired or replaced. The part(s) must be returned with freight prepaid and must be accompanied with a proof of the purchase. The part(s) must be packed with the greatest of care to ensure their protection.

3° The machine must not have been worn out, repaired or maintained by anyone without OREC's previous authorization. The machine must not have been damaged in a road accident, roughly handled or improperly used.

This guarantee does not compell OREC or its dealer to reimburse the labour costs or the carriage costs to the repairer.

NO OTHER GUARANTEE SHALL BE APPLIED TO THIS MACHINE EXCEPT THE LEGAL GUARANTEE. OREC SHALL NOT BE LIABLE FOR ANY DAMAGE OR COST INVOLVED BY THE MACHINE, FOR EXAMPLE :

1. HIRING COSTS
2. TURNOVER LOSSES
3. WORK DONE BY A REPLACING MACHINE

OREC DOES NOT TAKE ON ANY OTHER OBLIGATION AND DOES NOT AUTHORIZE ANYBODY TO TAKE ON ANY OTHER OBLIGATION THAN THOSE MENTIONED IN THE 3 PARAGRAPHS ABOVE.

To know the name of your dealer, report to: OREC

www.orec-jp.com

NOTES

A series of horizontal dotted lines for writing notes.