

RUSHTM

Packable Ramps

Operator's Manual
Original Operating Instructions

TX500 Aluminum Packable Ramp

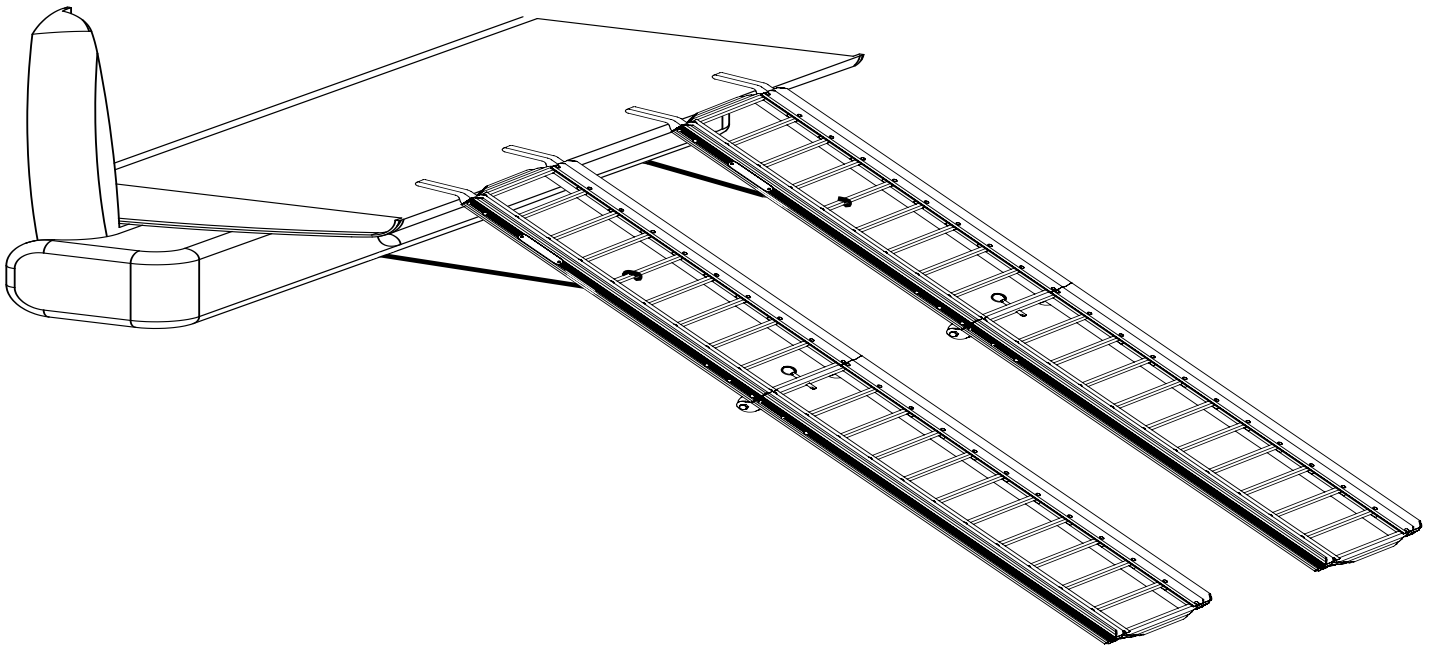

Visit us online at
www.rushramps.com



10320
Revised 03/02/12
© 2012 Ardisam, Inc.
All Rights Reserved.

RUSH™ Packable Ramps offers a line of ATV and UTV ramps. We appreciate your purchase of one of our world class ramps. Follow these few simple instructions and your product will be sure to give you many years of trouble free pleasure. Instructions should be kept in a safe place and reviewed at least annually.

If for any reason you have a problem with your product, **DO NOT return to the retailer**; contact the RUSH™ customer service department at 800-345-6007 Monday through Friday from 8 a.m. to 5 p.m. CST for assistance.

ASSEMBLY INSTRUCTIONS:

1. If your RUSH™ ramp is in its compressed position, pivot your ramp to separate rungs. Then unfold the ramp to lock rungs in proper position. **SEE FIGURE 1.**
2. Insert detent pin in hole at center rung on each section to lock ramp in place. **SEE FIGURE 1.**

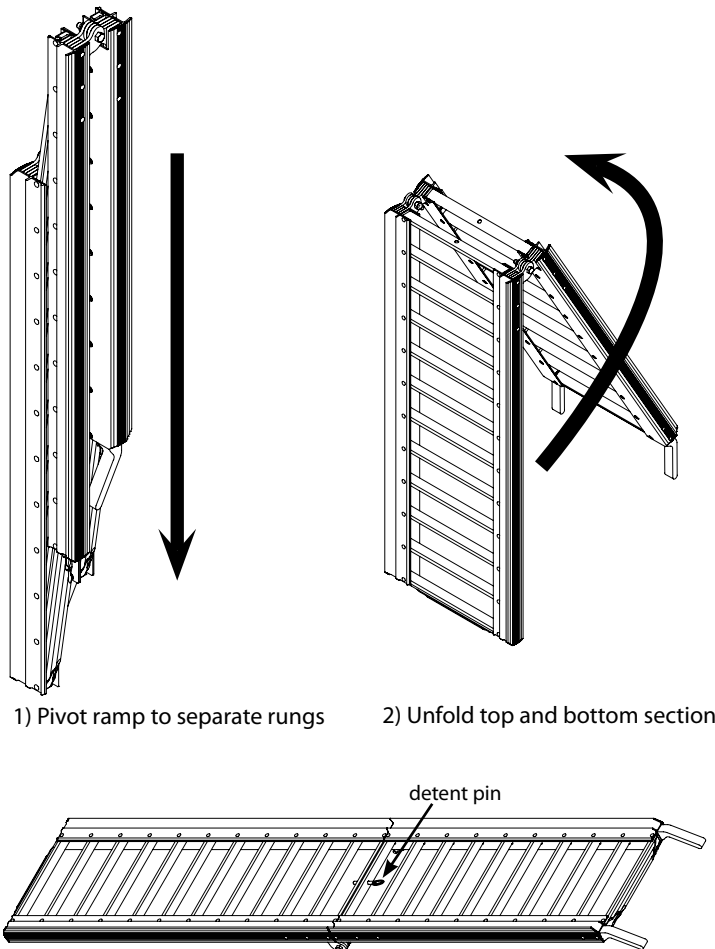

1) Pivot ramp to separate rungs 2) Unfold top and bottom section

3) Ramp rungs will automatically lock in position when unfolded. Lock top and bottom sections together using detent pin.

Figure 1

⚠ WARNING

- BE CAREFUL OF PINCH POINTS AT RAMP HINGE LOCATIONS.
- BE CAREFUL OF PINCH POINTS AT RAMP TAB LOCATIONS WHILE SECURING RAMP TO TAILGATE.
- BE CAREFUL OF PINCH POINTS BETWEEN RUNGS WHILE COLLAPSING RAMP.

⚠ WARNING

READ, UNDERSTAND AND FOLLOW ALL ASSEMBLY, INSPECTION, AND USE INSTRUCTIONS PROVIDED BEFORE EACH USE. FAILURE TO FOLLOW ALL INSTRUCTIONS, WARNINGS & LOAD CAPACITY RATING COULD RESULT IN SERIOUS INJURY OR DEATH.

IF ANY INSTRUCTIONS ARE NOT UNDERSTOOD OR IF YOU HAVE A PARTS ISSUE CALL 800-345-6007 BEFORE USING.

DO NOT USE AN ATV ON THIS RAMP IF THE ATV HAS SNOW CHAINS ON TIRES. CHAINS WILL CAUSE DAMAGE TO YOUR RAMP AND ARE HAZARDOUS!

THIS RAMP IS FOR USE WITH 4-WHEELED ATVS, UTVS, AND LAWN TRACTORS ONLY. DO NOT USE WITH 2- OR 3-WHEELED VEHICLES OR VEHICLES EXCEEDING 2,000 LB.

SAFETY STRAPS MUST BE SECURELY HOOKED UP TO VEHICLE TO PREVENT RAMPS FROM SLIDING OFF TAILGATE. TEST BEFORE USING OR YOU COULD BE SERIOUSLY INJURED. BE SURE YOUR TRUCK IS IN PARK AND EMERGENCY BRAKE ENGAGED.

BE SURE 4-WHEELED ATV, UTV, OR LAWN TRACTOR IS CENTERED ON RAMPS. DO NOT USE WITH ANY VEHICLE THAT HAS WIDER TIRES THAN THE RAMP WIDTH.

MAXIMUM USABLE HEIGHT, GROUND TO LOADING POSITION, IS NO MORE THAN ONE HALF THE LENGTH OF THE RAMP.

BE SURE RAMPS ARE PROPERLY PLACED AND SECURED AS DESCRIBED IN LOADING INSTRUCTIONS.

DO NOT USE ON SOFT SURFACES OR UNLEVEL TERRAIN.

REAR ENGINE EQUIPMENT SHOULD BE LOADED IN REVERSE TO AVOID FRONT END REAR-UP.

DO NOT EXCEED THE CAPACITY OF YOUR LOADING SURFACE (I.E. TAILGATE, BUMPER). IF UNKNOWN, CONSULT THE MANUFACTURER TO FIND LOAD CAPACITIES.

IF LOADING OR UNLOADING FROM A TRAILER, MAKE SURE THE TRAILER IS PROPERLY COUPLED TO THE TOW VEHICLE.

NEVER STAND IN THE PATH OF EQUIPMENT WHEN LOADING/ UNLOADING WITH THE RAMP, AND KEEP BYSTANDERS AWAY FROM THE RAMPS.

DO NOT STEP BETWEEN RUNGS. THIS MAY CAUSE A PERSON TO FALL THROUGH AND POSSIBLY RESULT IN SERIOUS BODILY INJURY.

RAMPS ARE INTENDED FOR LOADING/UNLOADING EQUIPMENT ONTO A TRAILER OR PICKUP TRUCK. DO NOT USE RAMP SECTIONS AS A LADDER, SCAFFOLDING, OR FOR ANY OTHER PURPOSE.

(assembly instructions continued...)

3. Attach the two provided securing straps to the fifth rung away from the tailgate end (one on each ramp). Wrap the loop end of each strap around the center brace and thread the buckle and "S" hook end through the loop. This permanently attaches straps to the ramp. **SEE FIGURE 2.**

USE INSTRUCTIONS:

TO LOAD YOUR 4-WHEELED ATV, UTV OR LAWN TRACTOR:

1. On level ground, rest both ramps on the tailgate. **SEE FIGURE 3.** Be sure ramps are centered on tailgate and aligned correctly to your four-wheeled ATV, UTV, or lawn tractor's wheel width.
2. Hook the "S" hooks of both straps to bumper and pull on loose end of straps until straps are tightly holding ramp to tailgate. Be sure ramps have not moved location when tightening straps. Double check to make sure ramps are still aligned correctly. To remove, simply push the thumb release on strap buckle.
3. Draw the ATV, UTV or lawn tractor up the ramps. We recommend using an electric or manual winch.
4. Once vehicle is in truck bed, be sure to set brake and securely tie down vehicle. Ramp can now be removed, folded up, and stored.

TO UNLOAD YOUR 4-WHEELED ATV, UTV OR LAWN TRACTOR:

1. Reverse loading procedures to unload your ATV, UTV, or lawn tractor.

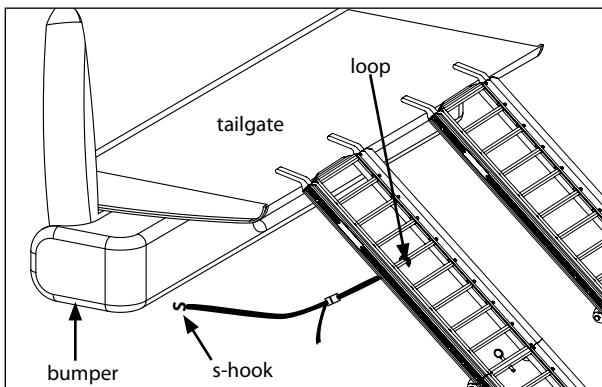

Figure 2

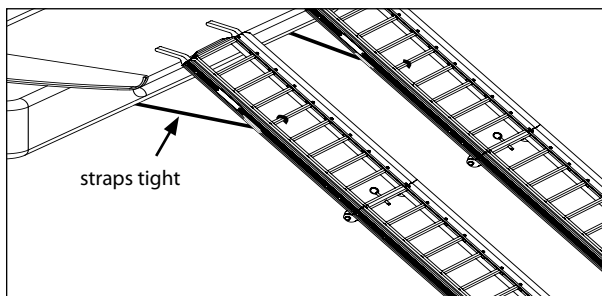

Figure 3

WARRANTY

RUSH™ Ramps, a division of Ardisam Inc., offers a one year limited warranty to be free from defects in materials and workmanship for the service life of the product, not to exceed twelve consecutive months from the date of purchase. This warranty applies to the original owner with a proof of purchase and is not transferable.

This warranty applies only to products which have not been subjected to negligent use, misuse, alteration, accident or if repairs have been made by anyone outside our factory. This warranty supersedes all other warranties either expressed or implied and all other obligations or liabilities on our part.

Ardisam, Inc., does not assume, and does not authorize any other person to assume for us, any liability in connection with the sale of our products. Warranty work must be sent directly to Ardisam, Inc. or one of our authorized service centers and performed by them.

To obtain warranty service and/or replacement instructions, you must have prior approval from Ardisam, Inc. before shipping your package to us by calling our customer service department at 800-345-6007 M-F 8-5 CST or by writing to: Ardisam, Inc., 1160 Eighth Avenue, Cumberland, WI 54829 for a return material authorization number (RMA#). All items must be shipped prepaid. Ardisam, Inc. will at no charge, repair or replace, at their discretion, any defective part which falls under the conditions stated above. Ardisam retains the right to change models, specifications and price without notice.

For replacement parts, phone 800-345-6007 or go online to www.rushramps.com.

ALWAYS...

- Use on level ground and securely attach ramp to truck.
- Be careful of pinch points at ramp hinge locations.
- Be careful of pinch points at ramp tab locations while securing ramp to tailgate, and of pinch points between rungs.
- Use as 4-wheeled ATV, UTV, or lawn tractor ramp only.
- Inspect before each and every use to be sure there is no product damage or loose/missing bolts and hardware. Lubricate hinges as necessary.

NEVER...

- Never exceed load capacity of 1,000 lb. per ramp (2,000 lb. as a pair), evenly distributed over four wheels.
- Use a damaged ramp; replace with new
- Use while under the influence of alcohol or drugs.
- Load ATV on ramp with any gear on racks of ATV.
- Use with 2- or 3-wheeled vehicles.
- Use carelessly -- Think Safety!
- Use in slippery conditions.

REPLACEMENT COMPONENTS

A306 Rubber tab cover

48663 Ramp strap, complete

RUSHTM
Packable Ramps

RUSHTM Packable Ramps
Division of Ardisam, Inc.
1160 8th Avenue, PO Box 666
Cumberland, WI 54829
800-345-6007 | Fax 715-822-2223
Email: info@ardisam.com