



INSTRUCTION MANUAL

DROP SPREADER 27.2kgs (60lb)

MODEL NO: THDS -- PRODUCT NO: 1938107001

EN - ORIGINAL INSTRUCTIONS

ASSEMBLY REQUIRED

SAVE THESE INSTRUCTIONS

SPARES & SUPPORT: 01793 333212

FOR YOUR SAFETY

Please read & understand this manual, paying attention to the safety instructions, before use.

Incorrect use of the product could put the operator or machine in danger.

Whilst every effort has been made to ensure the accuracy of information contained in this manual, our policy of continuous improvement determines the right to make modifications without warning.

Images used are for illustration purposes only

Copyright Notice

Copyright © Handy Distribution

Permission is granted to reproduce this publication for personal & educational use only.

Commercial copying, redistribution, hiring or lending is prohibited.

No part of this publication may be stored in a retrieval system or transmitted in any other form or means without written permission from Handy Distribution.

In all cases this copyright notice must remain intact.

CONTENTS

SPECIFICATION

IMPORTANT INFORMATION

GENERAL SAFETY INSTRUCTIONS

COMPONENTS

ASSEMBLY

OPERATION

RATE SETTINGS

MAINTENANCE

PARTS LIST & DIAGRAM

USER WARRANTY

NOTES

ASSEMBLY IS REQUIRED

This product requires assembly before use. See the "Assembly" section for instructions.

Please check that all parts required for the assembly of this spreader are included. If for any reason you believe a part for the assembly is missing or damaged, please contact us.

If you require any assistance with regards to the contents or operation of your machine, please contact us:

TEL: 01793 333212

**EMAIL: customerservice@handydistribution.co.uk
(MON – FRI 8.00AM TO 5.30PM EXCL. BANK HOLIDAYS)**

DO NOT USE WITH ROCK SALT.

Using rock salt in this spreader will damage the mechanism and shorten the life of the product. Refined ice melting salt can be used but the user should be aware that this is not a specialised salt spreader and using salt may corrode the spreader and reduce the life of the machine.

Clean the spreader thoroughly after using refined de-icing salt.

SPECIFICATION

The manufacturer reserves the right to change the product specification and livery according to continued product improvements.

Model	THDS
Product Number	1938107001
Capacity (Weight)	27kg (60lb)
Hopper Dimension	600x295x230mm
Spread Width	56cm (22")
Wheel Diameter	300mm (12")
Weight	N.W 5kg – G.W 6kg





IMPORTANT INFORMATION

INTENDED USE

The product is intended for spreading granular material for domestic gardens. This product is not intended for commercial use. Generally acknowledged accident prevention regulations and enclosed safety instructions must be observed.

Only perform work described in these instructions for use, any other use is incorrect. The manufacturer will not assume responsibility for damage resulting from such use.

SAFETY SYMBOLS

	Safety alert symbol. Used to alert you to potential personal injury hazards. Obey all safety messages that follow this symbol to avoid possible injury.
 DANGER	Indicates an imminently hazardous situation which, if not avoided, will result in serious injury.
 WARNING	Indicates a potentially hazardous situation which, if not avoided, could result in serious injury
 CAUTION	Indicates a potentially hazardous situation which, if not avoided, may result in minor or moderate injury.
CAUTION	Used without the safety alert symbol indicates a potentially hazardous situation which, if not avoided, may result in property damage.

GENERAL SAFETY INSTRUCTIONS

Read and understand the owner's manual and labels affixed to the product. Learn its application and limitations as well as the specific potential hazards. Retain these instructions for future reference. The operator is responsible for following the warnings & instructions in this manual and on the product.



STAY ALERT

Do not operate the machine while under the influence of drugs, alcohol, or any medication that could affect your ability to use it properly. Do not use this machine when you are tired or distracted from the job at hand. Be aware of what you are doing at all times. Use common sense.

AVOID DANGEROUS CONDITIONS

Make sure there is adequate surrounding workspace. Cluttered areas invite injuries. Keep your work area clean with sufficient light. Keep the area around the machine clear of obstructions, grease, oil, rubbish & other debris which could cause persons to fall onto moving parts.

INSPECT YOUR MACHINE

Check all bolts, nuts & screws for tightness before each use, especially those securing guards & drive mechanisms. Vibration during use, may cause these to loosen.

Replace damaged, missing or failed parts before using.

Warning labels carry important information. Replace any missing or damaged warning labels.

CRUSH AND CUT HAZARDS

Always keep your hands and feet clear from moving parts while operating the equipment.

Always keep the work area clean and clear when operating.

CONDITIONS

We recommend the machine is not used during winds. This may affect the spreading pattern.

DRESS PROPERLY

Do not wear loose clothing, gloves, scarfs, neckties or jewellery (rings, wrist watches, bracelets etc.), which can be caught in moving parts.

DO NOT OVERREACH

Keep proper footing and balance when using the machine. Never stand on the machine. Serious injury could occur if the machine is tipped or if the moving parts are unintentionally contacted. Do not store anything above or near the machine, where anyone might stand on the machine to reach them.

AVOID INJURY FROM UNEXPECTED ACCIDENT

Keep hands & feet out of the way of all moving parts. Do not place any part of your body or any tool e.g. in moving parts of the machine during operation.

DO NOT FORCE TOOL

Always work within the rated capacity. Do not operate for a purpose for which it was not intended.

MAINTAIN YOUR MACHINE WITH CARE

Clean the machine immediately after use. Keep the machine clean to ensure it operates to its full & safest performance. When maintaining this machine, only the manufacturer's original replacement parts should be used. The use of non-original manufacturer parts may invalidate your warranty.

PROTECT THE ENVIRONMENT

Take left over materials to an authorised collection point or follow the stipulations in the country where the machine is used. Do not discharge into drains, soil or water.

STORE IDLE EQUIPMENT

When not in use, the machine should be stored in a dry location. Keep the machine away from children and others not qualified to use it.

COMPONENTS













Remove the machine and contents from the carton. Be sure the carton is empty before discarding.

If you require any assistance with regards to the contents of the lawnmower contact us:

Tel: 01793 333212

Email: customerservice@handydistribution.co.uk

Mon to Fri - 8.00am to 5.30pm (excl. Bank Holidays)

Hex Bolt M6X30 7 PCS 	Hex Bolt M6X35 4PCS 	Screw M5X10 2PCS 	Carriage Bolt M6X35 2PCS 	Lock Nut M5 2PCS 	Lock Nut M6 2PCS 	Wire Crip Bottom Plate 1PC 
Wing Nut M6 10 PCS 	Flat Washer Ø12 3PCS 	Big Flat Washer Ø6 4PCS 	Cotter Pin Ø3X30 1PC 	Cotter Pin Ø5X45 1PC 	Wire Crip Plate 1PC 	

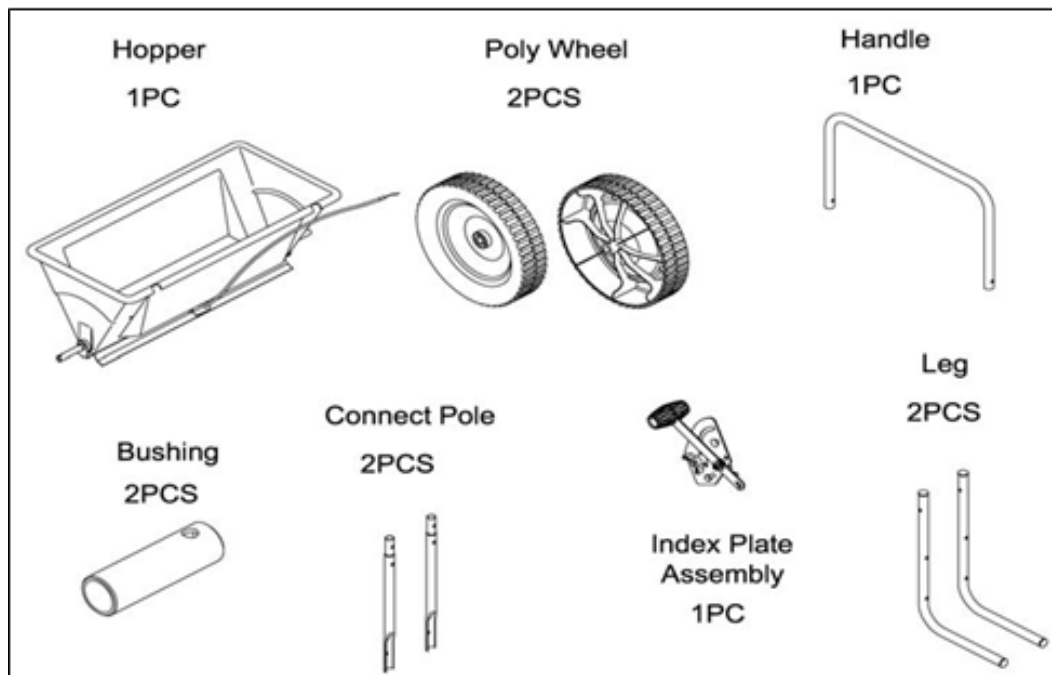

NOTE: Parts Lists are supplied for information purposes only, not all parts are stocked individually & we recommend you contact our Spares Team on 01793 333212 for expert advice.

ASSEMBLY

STEP 1

- Insert a Flat Washer $\varnothing 12$ onto the end of the left Wheel Axle (As you are stood behind the machine). Place the Bushing into a Poly Wheel and then onto the wheel axle. Then place a Flat Washer $\varnothing 12$ onto the Wheel Axle and insert a Cotter Pin $\varnothing 3 \times 30$ into the hole on the Wheel Axle and bend to lock it.
- Insert a Flat Washer $\varnothing 12$ onto the end of the right Wheel Axle. Place a Bushing in a Poly Wheel and then onto the Wheel Axle. Turn the wheel until the hole on the wheel is in-line with the hole on the wheel axle, insert the Cotter Pin $\varnothing 5 \times 45$ and bend to lock it.

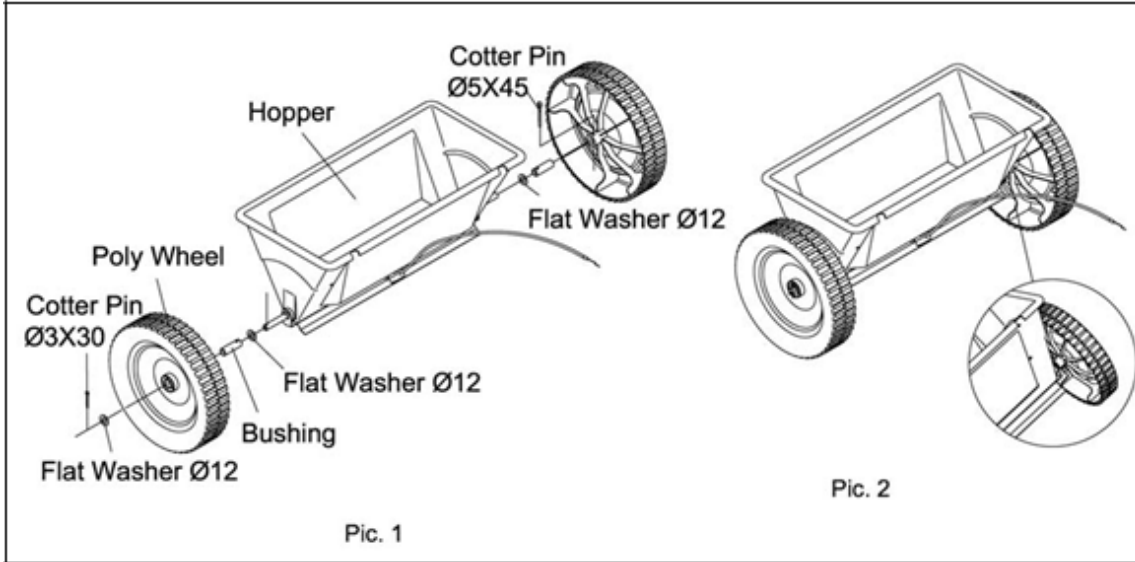

STEP 2

- Insert two Hex Bolts M6X35 with Big Flat Washers $\varnothing 6$ through the inner hopper and a leg, then lock using two Wing Nuts M6. Tighten the nuts.
- Repeat to assemble the second leg.

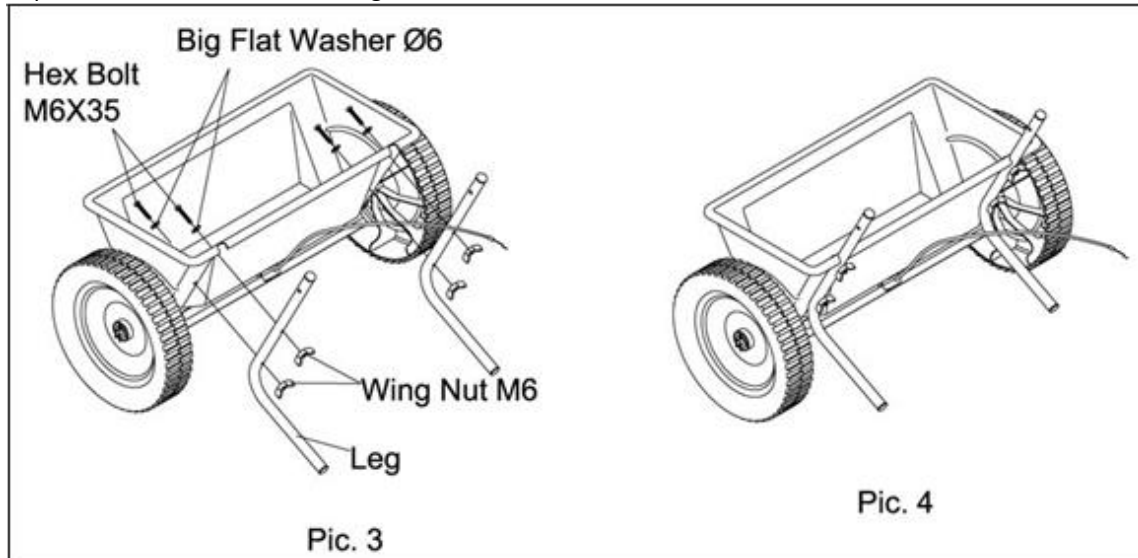

STEP 3

- As per Pic.5, place a Connect Pole onto the top of the leg and lock with a Carriage Bolt M6X35 and a Wing Nut M6.
- Repeat to assemble the second Connect Pole

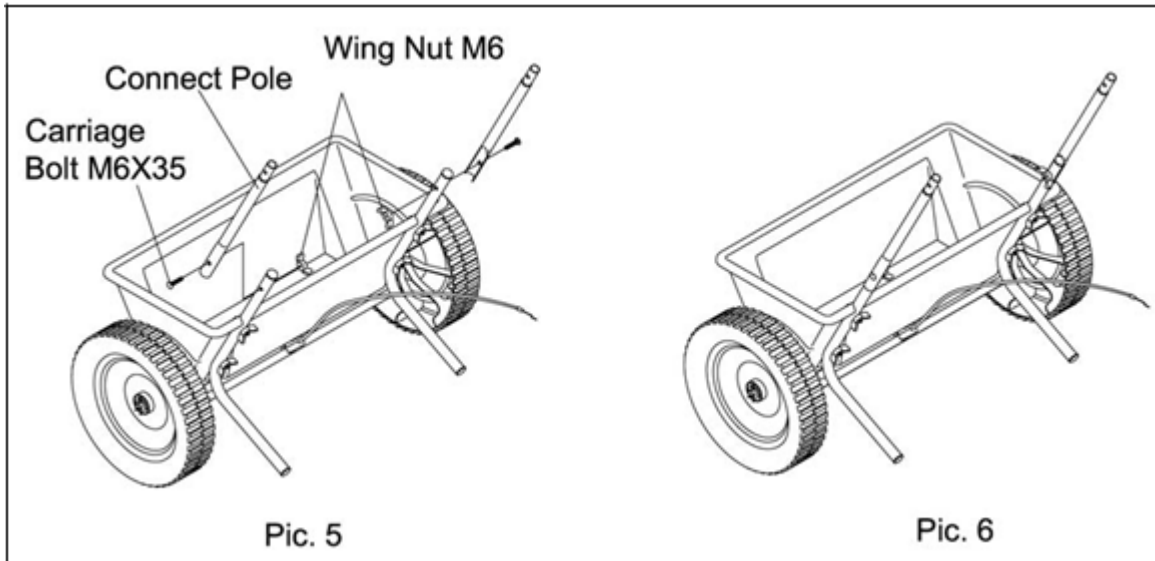

STEP 4

- Attach the Handle with the Connect Pole, lock using two Hex Bolts M6X30 and M6 Wing Nuts on the left.
- Insert the Adjustable Wire into the hole in the Index Plate, then attach the Index Plate onto the right side of the Handle and Connect Pole using two Hex Bolts M6x30, one Lock Nut M6 and one Wing Nut M6.
- Insert the Wire Clip Bottom Plate onto the Connect Pole using a Hex bolt M6x30 & Lock Nut M6.
- Fix the Wire Clip Plate to the Adjustable Wire and Wire Clip Bottom Plate using a Screw M5x10 and Lock Nut M5.

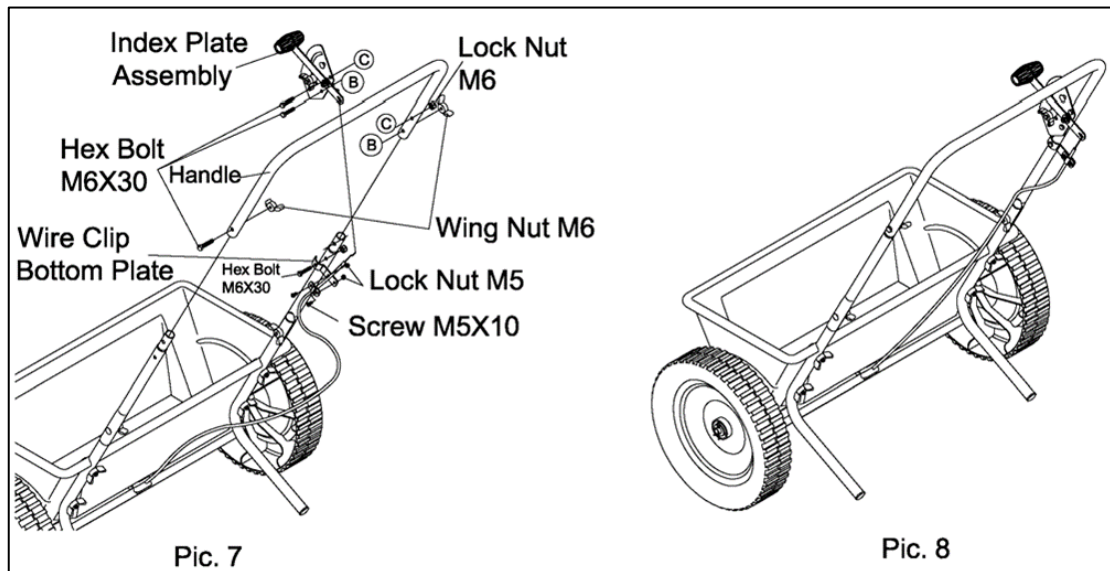

ADJUSTMENTS

4. Push the handle to the bottom position (25), to make sure the hole of the hopper is completely open.

2. Pull this handle to the top position.

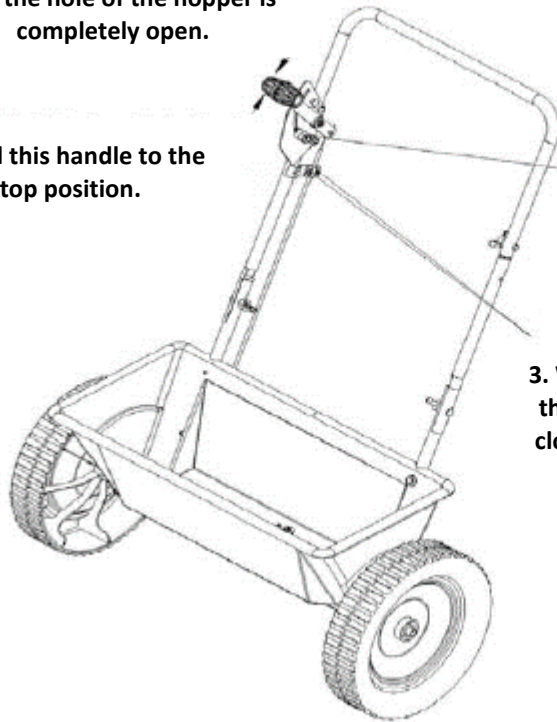

5. Move the position of the nut and change the space between the hole of the hopper and the rotating door.

1. Release these two bolts

3. When the handle is at 0, the hopper is completely closed. Tighten these two bolts.

OPERATION



DANGER

The product must only be put into operation if no defects are found. It is crucial that defective parts are replaced before the product is used again.

Check the safety equipment and the safe condition of the product.

Check all parts to make sure that they fit tightly.

Check whether there are any visible defects: broken parts, cracks, etc.



DANGER

DO NOT EXCEED THE EQUIPMENT MAXIMUM LOAD CAPACITY OF 27.2kgs (60lbs)

Before filling the hopper, familiarise yourself with the operation of this Spreader.

- The spreader is designed to be pushed at 3 miles per hour – brisk walking pace. The rate of walking will affect the spread pattern and flow rate.
- Move the wing nut attached to the stop bolt on the gauge to the relevant setting.
- Start pushing the spreader forward & pull the control lever back to the stop bolt, opening the feed-gate hole at the bottom of the hopper.
- Material which is stuck in the hopper bottom opening can cause uneven spreading.
- To stop spreading, push the gauge lever forward to close the feed-gate hole in the hopper.
- Salt may corrode the machine and reduce its working life. **DO NOT USE ROCK SALT.**
- If fertiliser is accidentally deposited too heavily in a small area, soak the area thoroughly with a garden hose or sprinkler to prevent burning the lawn.
- When spreading weed control fertilisers, make sure the broadcast pattern does not hit evergreen trees, flowers or shrubs.

RATE SETTINGS

Our spreaders are designed to spread dry, powdered or granulated materials thinly and evenly over reasonably smooth surfaces.

- Ensure that the material is dry and free-running. If in doubt pass it through a sieve with 3mm mesh to remove lumps.
- Set rate-setting dial to No 2.
- Fill the hopper approximately 3/4 full.
- Push the spreader forward and pull the control lever back to the stop bolt. If the spread is uneven or inadequate, close the feed-gate and reset the dial to a higher number.
- Always move off BEFORE opening the feed-gate and close the gate BEFORE stopping.

MULTI-USAGES	LBS/1,000 SQ FT	SPREADER SETTING	
FERTILISER	1	10	<p>The spreader settings are guidelines only. The spreader should be calibrated prior to application to ensure accuracy. The spreader settings are based on a walking speed of 3 MPH. Walking faster or slower will alter the spread application rate. Exact rates depend upon the spreader itself and the accuracy of the person operating it. Conversion charts are available online to convert to metric.</p>
	2	12	
	3	14	
	4	15	
	5	17	
GRASS SEEDS	6	18	
PESTICIDES	7	20	
	8	21	
	9	23	
	10	25	

OPERATION SPEED

3mph is a good speed to operate the spreader at. Walking slower or faster will alter the spread application rate. Do not exceed 10mph, to avoid personal injury and/or equipment damage.



CAUTION

The rate settings are guidelines only. Even branded materials may vary in grain size, humidity, density etc. If in any doubt choose a lower setting than that suggested or start at setting no. 20 and adjust as necessary, until an even spread is achieved.



WARNING

Do not over apply spreading material. Follow the recommended coverage rate for each product. Over application will lead to damage and contamination. If spreading material accidentally deposits too heavily, soak the area thoroughly with a garden hose or sprinkler to prevent burning.



CAUTION

DO NOT USE WITH ROCK SALT.

Using rock salt in this spreader will damage the mechanism and shorten the life of the product. Refined ice melting salt can be used but the user should be aware that this is not a specialised salt spreader and using salt may corrode the spreader and reduce the life of the machine. Clean the spread thoroughly after using refined de-icing salt.

CONSISTENT COVERAGE

To ensure consistent coverage, ensure each spread pattern slightly overlaps the previous, as shown below.
N.B. ALWAYS MOVE OFF BEFORE OPENING FEED-GATE.ALWAYS CLOSE FEED-GATE BEFORE STOPPING

SUGGESTED WALKING PATTERN

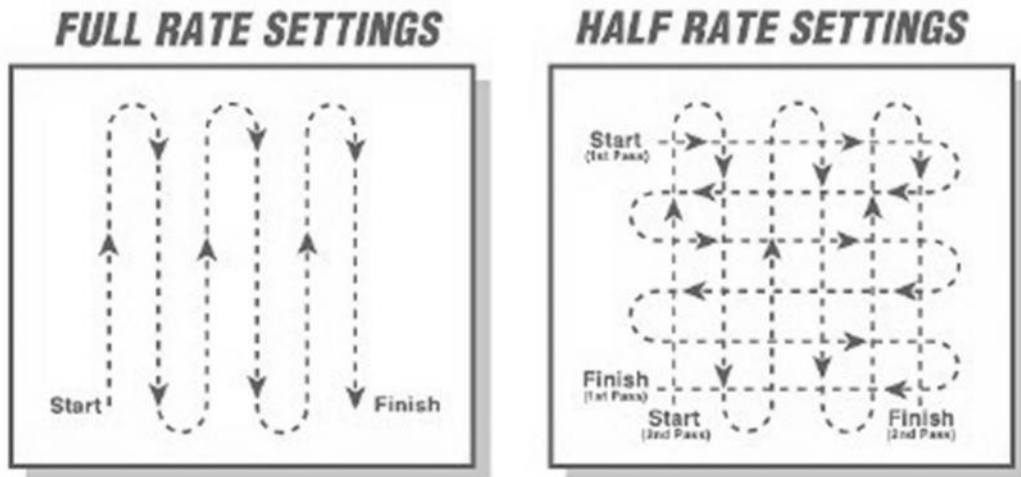

MAINTENANCE

LUBRICATE

Maintenance spray or multi-purpose grease can be applied to the wheel axle prior to long-term storage. Oiling is not necessary.

CLEANING

After each use thoroughly wash the spreader and clean material out of the hopper.

STORING

Never allow material to stay in the hopper for extended periods of time.

Before storing, ensure that the spreader is clean and dry.

Store indoors or in a protected area during severe weather and in the winter months.

Keep away from direct sunlight.

CHECK ALL NUTS, BOLTS AND FASTENING

Periodically check all fastenings are tight & secure.

NEVER EXCEED LOAD CAPACITY

To avoid damaging the spreader, never exceed the rated load capacity of 27.2kg (60lb).

PARTS LIST & DIAGRAM – THDS (1938107001)

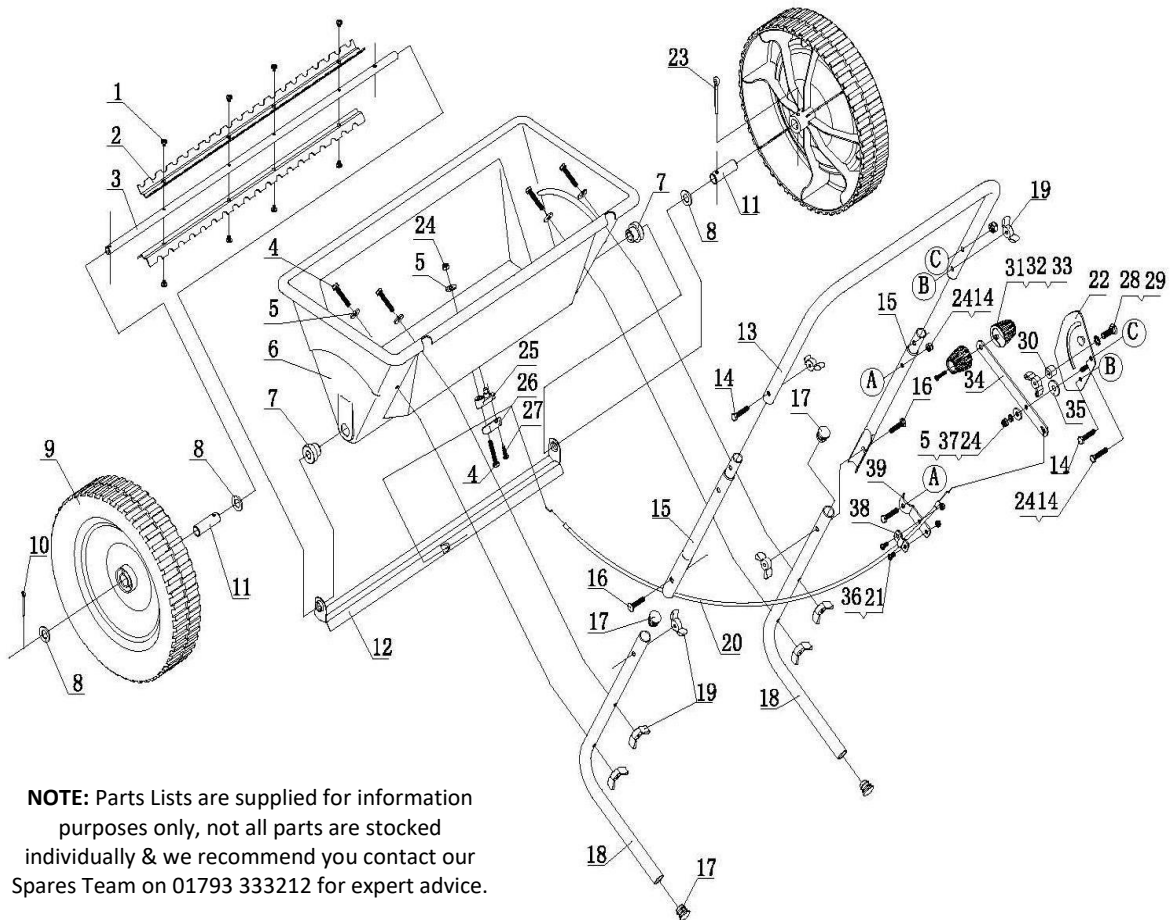

NOTE: Parts Lists are supplied for information purposes only, not all parts are stocked individually & we recommend you contact our Spares Team on 01793 333212 for expert advice.

NO.	PART NO.	DESCRIPTION	QTY
1	TH163-1	Screw M5x6	8
2	TH163-2	Scratch Board	2
3	TH163-3	Wheel Axle	1
4	TH163-4	Hex Bolt M6X35	5
5	TH163-5	Big Flat Washer Ø6	6
6	TH163-6GM	Hopper	1
7	TH163-7	Axle Bushing	2
8	TH163-8	Flat Washer Ø12	3
9	TH163-9	Poly Wheel	2
10	TH163-10	Cotter Pin Ø3X30	1
11	TH163-11	Bushing	2
12	TH163-12	Rotating Door Assembly	1
13	TH163-13GM	Handle	1
14	TH163-14	Hex Bolt M6X30	4
15	TH163-15GM	Connect Pole	2
16	TH163-16	Carriage Bolt M6X35	2
17	TH163-17GM	End Cap	4
18	TH163-18GM	Support Leg	2
19	TH163-19	Wing Nut	9
20	TH163-20	Adjustable Wire	1

NO.	PART NO.	DESCRIPTION	QTY
21	TH163-21	Screw M5X10	2
22	TH163-22	Index Plate Assembly	1
23	TH163-23	Cotter Pin Ø5X45	1
24	TH163-24	Nylon Lock Nut M6	4
25	TH163-25	Wire Lock -1	1
26	TH163-26	Wire Lock -2	1
27	TH163-27	Screw ST.4.8x20	1
28	TH163-28	Carriage Bolt M6X25	1
29	TH163-29	Lock Washer Ø8	1
30	TH163-30	Spacer	1
31	TH163-31	Adjustable Handle A	1
32	TH163-32	Adjustable Handle B	1
33	TH163-33	Screw ST.4.2x18	1
34	TH163-34	Adjustable Handle Rod	1
35	TH163-35	Nylon Washer	1
36	TH163-36	Nylon Lock Nut M5	2
37	TH163-37	Lock Washer Ø6	1
38	TH163-38	Wire Clip plate	1
39	TH163-39	Wire Clip Bottom Plate	1

GJ HANDY & CO LTD USER WARRANTY POLICY

Users Statement of Warranty

Each new machine is warranted against defective material or assembly of material under normal usage. The warranty applies to the original purchaser and covers faulty parts and the labour involved in replacing and repairing those parts, which are of original manufacture.

Period of Warranty

Webb (excludes Electric Handheld, Dynamic, Heritage, Legacy), Webb Pro, Sanli Engine

- a) 2 years from the original date of sale to the first domestic user.
- b) 90 days from the original date of sale to the professional/commercial user.
- c) 90 days from the original date of sale when used for hire.
- d) A reduced warranty period of 90 days applies to those items which are subject to normal wear and tear (e.g. but not limited to wheels, tyres, cutter bars, cylinders, cutting blades, blade boss, belts, cables, nylon line & spool, collection bags, spark plugs).
- e) Engines are supplied with a separate warranty to the machine. The engine manufacturers warranty statement which will be supplied within the engine instruction manual. All enquiries and warranty repairs should be discussed with the engine manufacturer or approved warranty repair dealer.
- f) 90 days from the original date of purchase for Replacement Spare Parts (unless normal wear & tear component, which are covered for 30 days).
- g) All machines' must be serviced within the first 12 months from the original date of purchase to comply with the warranty, failure to do so will invalidate the 2nd year of the warranty.

Webb Electric Handheld, Webb Dynamic, Heritage & Legacy, Handy, Mowerland, Q-Garden

- a) 1 year from the original date of sale to the first domestic user.
- b) 90 days from the original date of sale to the professional/commercial user.
- c) 90 days from the original date of sale when used for hire.
- d) A reduced warranty period of 90 days applies to those items which are subject to normal wear and tear (e.g. but not limited to wheels, tyres, cutter bars, cylinders, cutting blades, blade boss, belts, cables, nylon line & spool, collection bags, spark plugs).
- e) Engines are supplied with a separate warranty to the machine. The engine manufacturers warranty statement which will be supplied within the engine instruction manual. All enquiries and warranty repairs should be discussed with the engine manufacturer or approved warranty repair dealer.
- f) 90 days from the original date of purchase for Replacement Spare Parts (unless normal wear & tear component, which are covered for 30 days).

All warranty repairs must be undertaken by an authorised service dealer. These dealers have been accredited by GJ Handy & Co Ltd and agree to only use genuine parts and follow our repair procedures.

Not covered by this warranty

- a) The warranty policy does not cover any depreciation or damages caused by ordinary wear, rusting or corrosion, lack of correct maintenance or operation, misuse, abuse, lack of transportation or accident.
- b) The warranty policy does not cover any costs necessary for the standard periodic maintenance services instructed by the operator's manual, or service parts replacement which would include oil, filters, tyres, belts, brake linings, fuses, blades, seals and other service parts unless it can be proven that the item has evidence of faulty manufacture.
- c) The warranty policy will not cover failure or damage caused as a result of parts or accessories being modified without the written approval of GJ Handy & Co Ltd.

- d) The warranty policy will not cover the unit if non-genuine parts have been fitted and as a result damage has occurred to the unit.
- e) The warranty policy is non-transferable and is only applicable to the original purchaser.

Disclaimer

- a) This warranty is only a remedy for defect of products. GJ Handy & Co Ltd will never warranty in terms of the merchantability or the fitness for a particular purpose.
- b) No person is authorised to make any warranties, representations or promises, expressed or implied, on behalf of GJ Handy & Co Ltd, or to modify the terms conditions or limitation of this warranty policy in any way.
- c) Neither GJ Handy & Co Ltd nor any company affiliated with GJ Handy & Co Ltd shall be liable in any event or manner whatsoever for incidental or consequential damages or injuries, including, but not limited to, loss of crops, loss of profit, out of pocket expenses or profits, rental of substitute equipment or other commercial losses.

General

- a) Most warrantable failures show up within the first few weeks of use. These failures are usually straightforward and warranty assessment is relatively easy.
- b) Failures relating to cutter decks and belts need careful investigation, as the cause may not always be straightforward. Look for damage to blades and pulleys especially when the cutter belt or blade boss have snapped or cracked as this could be due to impact damage.
- c) Customers should always refer to the operator/instruction manual when any disputed problem arises, you will find most areas covered within the manual.

Version 7 (Dec 2018)

**For spares or support of your Handy product,
please contact us:**

Tel: 01793 333212

**Email: customerservice@handydistribution.co.uk
(Mon – Fri 8.00am to 5.30pm excl. Bank Holidays)**

To see our range of garden machinery & equipment visit:

www.thehandy.co.uk

Making gardening easier & affordable since 1938

Distributed by Handy Distribution, Murdock Road, Dorcan, Swindon, SN3 5HY