



50cm Hedge Trimmer

with 20V 2Ah Lithium-Ion Battery & Charger

WEV20HT
1938201001

en - Original Instructions

Sales & Support: 01793 333212

Before use please read & understand this manual; paying particular attention to the safety instructions.
The manufacturer reserves the right to change the product specification and livery according to continues product improvements.



INSTRUCTION MANUAL

18 March 19

Copyright Notice

Copyright © Handy Distribution

Permission is granted to reproduce this publication for personal & educational use only.
Commercial copying, redistribution, hiring or lending is prohibited.

No part of this publication may be stored in a retrieval system or transmitted in any other form or means without written permission from Handy Distribution.

In all cases this copyright notice must remain intact.

CONTENTS

SPECIFICATION

IMPORTANT INFORMATION

GENERAL SAFETY INSTRUCTIONS

KNOW YOUR MACHINE

BATTERY

CHARGING

OPERATION

CLEANING & MAINTENANCE

STORAGE & TRANSPORTATION

TROUBLE SHOOTING

PARTS DIAGRAM & LIST

EC DECLARATION OF CONFORMITY

SPECIFICATION

Model	WEV20HT
Product Number	1938201001
Voltage	18Vd.c (20Vd.c Max)
No Load Speed	1200 rpm
Blade Length	500 mm
Cutting Capacity	16 mm
Maximum Run Time (Unloaded)	45 mins
Charge Time (Up to)	4 hours
Guarantee Sound Power Level	L _{WA} 99 dB(A) - K _{PA} 3 dB(A)
Vibration	Front Handle 1.55 m/s ² , Rear Handle 1.58 m/s ² Uncertainty K: 1.5 m/s ²
Weight without Battery	N.W 2.8kg

Consistent with our policy of continuous improvement, WEBB reserves the right to change the design and configuration of any of its products without notice or obligation. Therefore, please treat the text and images in this manual for illustrative purposes only. They may in no case serve as a basis for any legal claim.

If you require any assistance with regards to the contents or operation of your machine, please call our Customer Service Team on 01793 333212 or email customerservice@webbgardenpower.co.uk (Monday to Friday 8.00am to 5.30pm excl. Bank Holidays)



INSTRUCTION MANUAL

IMPORTANT INFORMATION



WARNING

Read this instruction manual carefully before operating this machine. Make sure that you are familiar with the controls and properly operate the machine. Following these instructions to reduce the risk of fire, electric shock and personal injury.

IF NOT USED PROPERLY THIS MACHINE CAN BE DANGEROUS!

This machine can cause serious injury to the operator and others, the warning and safety instructions must be followed to ensure reasonable safety and efficiency in using this product. The operator is responsible for following the warning and safety instructions in this manual and on the machine. Never use the product unless the fixing screws or guards are correctly positioned.

DESIGNED FOR DOMESTIC USE ONLY.

The Hedge Trimmer is designed for use in private gardens, whose annual use does not generally exceed 50 hours and that are primarily used for tending HEDGES or BUSHES, but not in public facilities, parks or sports grounds and not for agricultural or forestry use.

Compliance with this manual supplied by the manufacturer is a prerequisite for the proper usage of the machine. The operating manual contains servicing and maintenance instructions as well as directions for use.

TRAINING

Read the instructions carefully: Be familiar with the controls and the proper use of the equipment.

















Never let children or other persons who have not read these instructions use the device. Persons younger than 16 must not use the device. Local regulations may determine the minimum age for users.

Never operate while people, especially children, or pets are nearby.

Keep in mind that the operator or user is responsible for accidents or hazards involving the machine that occur to other people or their property.

GENERAL SAFETY INSTRUCTIONS

It is important that you read and understand the owner's manual and labels affixed to the machine. Learn its application and limitations as well as the specific potential hazards. Retain these instructions for future reference. The operator is responsible for following the warnings & instructions in this manual and on the product.

	Read & understand operator's manual before using the machine. Failure to follow instructions could result in death or serious injury.		Always hold the hedge trimmer with both hands when operating.
	Wear gloves to protect your hands Wear safety shoes.		Check your machine before turning it on. Keep guards in place & in working order. Frequently check to see that foreign objects are removed from the working area before turning it on. Replace damaged, missing or failed parts before using it.
	Whenever the machine is in use, safety glasses must be worn to safeguard against flying objects. Hearing protection must also be used to protect the users hearing. Face masks are also recommended to avoid inhalation of debris.		Do not expose to rain or damp conditions
	Keep all bystanders & animals at least 15 metres away from the machine during operation. If approached, stop the machine immediately.		STAY ALERT Safety alert symbol. Used to alert you to potential personal injury hazards. Obey all safety messages that follow this symbol to avoid possible injury.
 DANGER	Indicates an imminently hazardous situation which, if not avoided, will result in serious injury.	 WARNING	Indicates a potentially hazardous situation which, if not avoided, could result in serious injury.
 CAUTION	Indicates a potentially hazardous situation which, if not avoided, may result in minor or moderate injury.	CAUTION	Used without the safety alert symbol, indicates a potentially hazardous situation which, if not avoided, may result in property damage.
	According to the European directive 2012/19/EU for Waste Electrical & Electronic Equipment and its implementation into national law, electrical and electronic equipment that are no longer usable must be collected separately & disposed of in an environmentally correct manner.		Sound Power Level (Image used for illustration purposes only, check machine and Declaration of Conformity for actual reading)
	CE marking is a certification mark that indicates conformity with health, safety, and environmental protection standards for products sold within the European Economic Area.		Separate collection of used products and packaging allow materials to be recycled & used again. Reuse of recycled materials helps prevent environmental pollution and reduces the demand for raw material.



INSTRUCTION MANUAL

GENERAL SAFETY WARNINGS



WARNING:

Read all safety warnings and all instructions. Failure to follow the warnings and instructions may result in electric shock, fire and/or serious injury. Save all warnings and instruction for future reference. The term “power tool” in the warnings refers to your battery-operated (cordless) power tool.

WORK AREA SAFETY

Keep work area clean and well lit. Cluttered or dark areas invite accidents.

Do not operate power tools in explosive atmospheres, such as in the presence of flammable liquids, gases or dust. Power tools create sparks which may ignite the dust or fumes.

Keep children and bystanders away while operating a power tool. Distractions can cause you to lose control.

ELECTRICAL SAFETY

Avoid body contact with earthed or grounded surfaces, such as pipes, radiators, ranges and refrigerators. There is an increased risk of electric shock if your body is earthed or grounded.

Do not expose power tools to rain or wet conditions. Water entering a power tool will increase the risk of electric shock.

PERSONAL SAFETY

Stay alert, watch what you are doing and use common sense when operating a power tool. Do not use a power tool while you are tired or under the influence of drugs, alcohol or medication. A moment of inattention while operating power tools may result in serious personal injury.

Use personal protective equipment. Always wear eye protection. Protective equipment such as dust mask, non-skid safety shoes, hard hat, or hearing protection used for appropriate conditions will reduce personal injury.

Prevent unintentional starting. Ensure the switch is in the off-position before

connecting to battery, picking up or carrying the tool. Carrying power tools with your finger on the switch or energising power tools that have the switch on invites accidents.

Do not overreach. Keep proper footing and balance at all times. This enables better control of the power in unexpected situations.

Dress properly. Do not wear loose clothing or jewellery. Keep your hair, clothing and gloves away from moving parts. Loose clothes, jewellery or long hair can be caught in moving parts.

POWER TOOL USE AND CARE

Do not force the power tool. Use the correct power tool for your application. The correct power tool will do the job better and safer at the rate for which it was designed.

Do not use the power tool if the switch does not turn it on and off. Any power tool that cannot be controlled with switch is dangerous and must be repaired.

Disconnect the battery from the power tool before making any adjustments, changing accessories, or storing power tools. Such preventive safety measures reduce the risk of starting the power tool accidentally.

Store idle power tools out of the reach of children and do not allow persons unfamiliar with the power tool or these instructions to operate the power tool.

Power tools are dangerous in the hands of untrained users.

Maintain power tools. Check for misalignment or binding of moving parts, breakage of parts and any other condition that may affect the power tool's operation. If damaged, have the power tool repaired before use. Many accidents are caused by poorly maintained power tools.

Keep cutting tools sharp and clean. Properly maintained cutting tools with sharp cutting edges are less likely to bind and are easier to control.

Use the power tool, accessories and tool bits etc. in accordance with these

instructions, taking into account the working conditions and the work to be performed. Use of the power tool for operations different from those intended could result in a hazardous situation.

BATTERY TOOL USE AND CARE

Recharge only with the charger specified by the manufacturer. A charger that is unsuitable for one type of battery may create a risk of fire when used with another battery.

Use power tools only with specifically designated battery. Use of any other battery may create a risk of injury and fire. When the battery is not in use, keep it away from other metal objects, like paper clips, coins, keys, nails, screws or other small metal objects, which can make a connection from one terminal to another. Shorting the battery terminals together may cause burns or a fire.

Under abusive conditions, liquid may be ejected from the battery; avoid contact. If contact accidentally occurs, flush with water. If liquid contacts eyes, additionally seek medical help. Liquid ejected from the battery may cause irritation or burns.

SERVICE

Have your power tool serviced by a qualified repair person using only identical replacement parts. This will ensure that safety of the power tool is maintained.

HEDGE TRIMMER SAFETY WARNINGS

Keep all parts of the body away from the cutter blade. Do not remove cut material or hold material to be cut when blades are moving. Make sure the switch is off when clearing jammed materials. A moment of inattention while operating the hedge trimmer may result in serious personal injury.

Carry the hedge trimmer by the handle with cutter blade stopped. When transporting or storing the hedge trimmer always fit the cutting device cover. Proper handling of the hedge trimmer will reduce possible personal injury from the cutter blades.

Hold the power tool by insulated gripping

surface only, because the cutter blade may contact hidden wiring. Cutter blades contacting a “live” wire may make exposed metal parts of the power tool “live” and could give the operator an electric shock.

ADDITIONAL SAFETY RULES

Clear the work area before each use.

Remove all objects such as cords, lights, wire, or string which can be thrown or become entangled in the cutting means.

Beware of thrown objects; keep all bystanders, children, and pets at least 15m away from work area.

Do not operate in poor lighting. The operator requires a clear view of the work area to identify potential hazards.

Inspect the machine before each use. Check for loose fasteners, fuel leaks, etc. Make sure all guards, and handles are properly and securely attached. Replace any damaged parts before use. Check for battery pack leaks.

Do not modify the machine in any way.

Do not allow children or untrained individuals to use this unit.

Wear full eye and hearing protection while operating the product. If working in an area where there is a risk of falling objects, head protection must be worn.

Secure long hair so it is above shoulder level to prevent entanglement in moving parts.

Do not use this machine when you are tired, ill, or under the influence of alcohol, drugs, or medication.

Keep firm footing and balance. Do not overreach. Overreaching can result in loss of balance or exposure to hot surfaces.

Before starting the machine, make sure the cutting blades will not come in contact with anything.

While operating the hedge trimmer, always hold it firmly with both hands by the two handles and ensure that the operating position is safe and secure.

Blades are sharp. When handling the blade assembly, wear non-slip, heavy-duty protective gloves. Do not place your hand or fingers between blades or in any position



INSTRUCTION MANUAL

where they could get pinched or cut. **NEVER** touch blade or service unit unless the battery pack is removed.

Switch off and remove the battery pack off before:

1. adjusting the working position of the cutting device
2. cleaning or clearing a blockage
3. leaving the product unattended
4. checking, maintenance or working on the machine

Do not force the hedge trimmer through heavy shrubbery. This can cause the blades to bind and slow down. If the blades slow down, reduce the pace.

Do not attempt to cut stems or twigs that are larger than 16 mm thick, or those obviously too large to feed into the cutting blade. Use a non-powered hand saw or pruning saw to trim large stems.

Use of hearing protection reduces the ability to hear warnings (shouts or alarms).

The operator must pay extra attention to what is going on in the working area.



WARNING:

If the machine is dropped, suffers heavy impact or begins to vibrate abnormally, immediately stop the machine and inspect for damage or identify the cause of the vibration. Any damage should be properly repaired or replaced by an authorised service centre.

TRANSPORTATION & STORAGE

Stop the machine, remove the battery and allow both to cool before storing or transporting

Clean all foreign material from the product. Store it in a cool dry and well-ventilated place that is inaccessible to children. For extra safety, store the battery separately from the hedge trimmer. Keep away from corrosive agents such as garden chemicals and de-icing salts. Do not store outdoors. Cover the blade with the blade protector before storing the unit, or during transportation.

For transportation, secure the machine against movement or falling to prevent injury to persons or damage to the machine.

MAINTENANCE



WARNING:

Use only original manufacturer's replacement parts, accessories and attachments. Failure to do so can cause possible injury, poor performance and may void your warranty.



WARNING:

Servicing requires extreme care and knowledge and should be performed only by a qualified service technician. For service we suggest you return the product to your nearest authorized service center for repair. When servicing, use only identical replacement parts.



WARNING:

The blades are extremely sharp. To prevent personal injury, exercise extreme caution when cleaning, lubricating and fitting or removing the blade protector.

Remove the battery before adjusting, maintaining or cleaning.

You may make adjustments and repairs described here. For other repairs, contact the authorised service agent.

After each use, clean the body and handles of the product with a soft dry cloth.

After each use, clean the debris from the blades with a stiff brush, and then carefully apply a rust preventative lubricant before refitting the blade protector. It is recommended you use a rust preventative and lubricant spray to apply an even distribution and reduce the risk of personal injury from contact with the blades. For information about suitable spray product, check with your local authorised service centre. You may wish to lubricate the blades lightly before use if necessary, using the above method.

Check all nuts, bolts and screws at frequent intervals for proper tightness to ensure the product is in safe working condition. Any part that is damaged should be properly repaired or replaced by an authorised service centre.

INTENDED USE

The product is only intended for use outdoors. For safety reasons the product **MUST** be adequately controlled by using the two-handed operation. The product is designed for home or domestic use. It is intended to cut and trim hedges, shrubs and similar vegetation.

It should be used in dry, well illuminated conditions.

It is **NOT** intended to cut grass, trees or branches. It should not be used for any other purpose than hedge trimming.

RESIDUAL RISK

Even when the product is used as described, it is still impossible to completely eliminate certain residual risk factors. The following hazards may arise in use and the operator should pay special attention to avoid the following:

1. The blades cannot be guarded whilst cutting. Contact with the blades can cause serious injury. Keep the blade away from yourself and others. Cover it with the blade protector whenever you are not cutting.
2. Injury caused by vibration. Always use the right tool for the job, use designated handles and restrict working time and exposure.
3. Exposure to noise can cause hearing injury. Wear ear protection and limit exposure

RISK REDUCTION

It has been reported that vibrations from hand-held tools may contribute to a condition called Raynaud's Syndrome in certain individuals. Symptoms may include tingling, numbness and blanching of the fingers, usually apparent upon exposure to cold. Hereditary factors, exposure to cold and dampness, diet, smoking and work

practices are all thought to contribute to the development of these symptoms. There are measures that can be taken by the operator to possibly reduce the effects of vibration:

1. Keep your body warm in cold weather. When operating the unit wear gloves to keep the hands and wrists warm. It is reported that cold weather is a major factor contributing to Raynaud's Syndrome.
2. After each period of operation, exercise to increase blood circulation.
3. Take frequent work breaks. Limit the amount of exposure per day.

If you experience any of the symptoms of this condition, immediately stop use and see your doctor about these symptoms.



WARNING:

Injuries may be caused, or aggravated, by prolonged use of a tool. When using any tool for prolonged periods, ensure you take regular breaks.



DANGER OF FIRE!

Never charge batteries in the vicinity of acids or easily flammable materials. Charge battery only at a temperature between 10 - 45 °C. After a heavy load, first allow the battery to cool.



DANGER OF EXPLOSION!

Protect the device from direct exposure to heat and fire. Do not place on heating units or expose to strong sunlight for an extended period. Operate the device only at temperatures between -10 °C to + 45 °C..



RISK OF SHORT CIRCUIT!

For disposal, transport or storage, pack the battery in a plastic bag or a cardboard box, or isolate the contacts with adhesive tape. Do not open the battery pack.



INSTRUCTION MANUAL

OPERATING TIMES

Please check noise abatement regulations prevailing in your country.

SAFE DISPOSAL OF BATTERIES



Our batteries are designed according to the latest state of technology and optimised for the use in electric tools. Lithium ion cells contain hazardous substances and may therefore not be disposed off with normal household waste. Our batteries are lithium ion cells and are therefore subject to special disposal regulations. Bring defective batteries to your specialist dealer. Before disposing of the tool, remove the battery. We wish to encourage users to act in an environmentally friendly manner.

KNOW YOUR MACHINE

1. Rear Handle	2. Trigger
3. Front Handle	4. Safety Lever
5. Hand Guard	6. Blade Assembly
7. Blade Guard	8. Battery 2Ah
9. Charger	

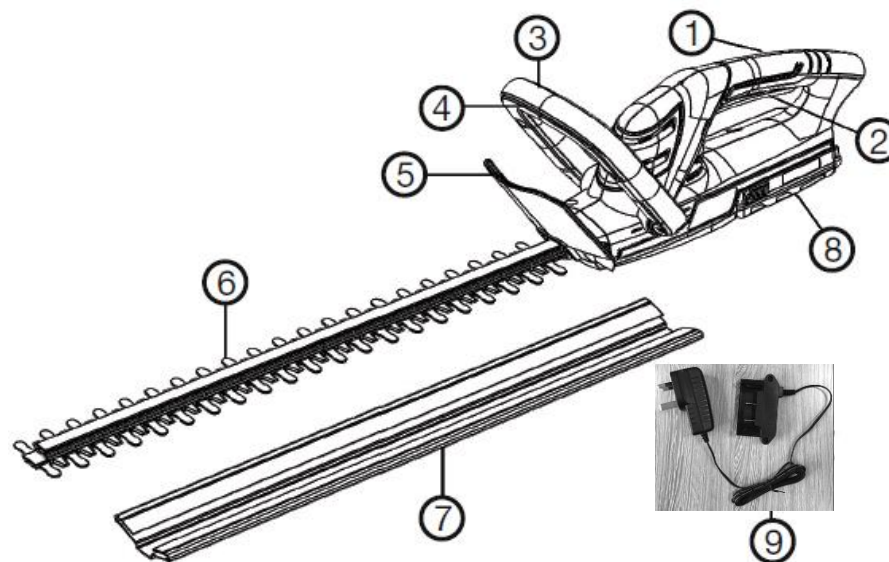

BATTERY

CARE

- There will be some charge present in the Battery on delivery, but to ensure maximum running time, charge your Battery for 4-hours before first use.
- If over a period of time the Battery quickly runs down after a full 4-hour charging period, a replacement Battery is needed.
- To prevent permanent Battery damage, never store in a discharged condition.
- Contact your retailer or local approved service dealer for a replacement Battery and for safe disposal of your old Battery.
- The Battery is a "High Power", 20 Volt 2.0 Amp-Hour item. It is "Sealed for Life and no maintenance is required."

IMPORTANT

Dispose of your old battery safely. Do not cut open, burn or incinerate.

WINTER STORAGE

- Fully charge for 4-hours before winter storage.
- Re-charge the Battery every 3 to 4 months for a full 4-hour charging period to top up the battery during winter storage.
- Avoid extended storage without recharging.
- Store in a cool dry place.



INSTRUCTION MANUAL

CHARGING



The battery must be charged for approximately 4 hours before using it for the first time. Use only the original charger supplied with this machine or approved replacement. Use charging unit only in dry rooms.

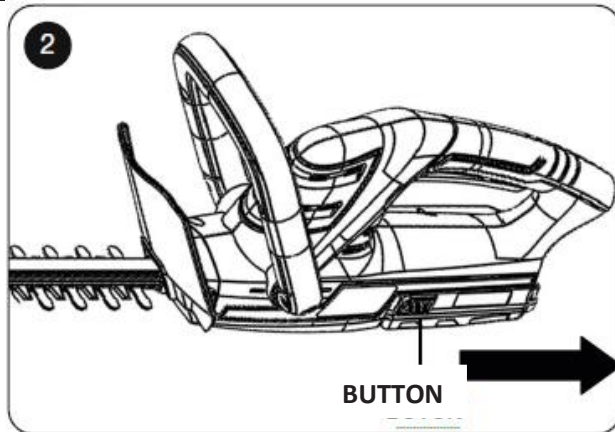

- Remove the battery from the grass trimmer. Apply pressure to both side release buttons to release the battery and slide it towards the rear of the machine.
- Connect the charger to the power mains.
- Insert battery in the charger, ensuring an audible click is heard.

CHARGING LIGHTS

Remove the battery from the charger once it is fully charged. Charging an empty battery will take up to 4 hours to fully recharge.

WINTER STORAGE

- Fully charge for 4-hours before winter storage.
- Re-charge the Battery every 3 to 4 months for a full 4-hour charging period to top up the battery during winter storage.
- Avoid extended storage without re-charge.
- Store in a cool dry place.

GENERAL INSTRUCTIONS:

In order to maintain the long service life of the battery, always follow the instructions below: The line trimmer will automatically switch off when the battery voltage is low. The battery must then be recharged before the tool can be used again.

Always recharge the lithium-ion battery prior to any prolonged period of non-use, i.e. before storing away in autumn/winter.

The charging time is 4-hours maximum for a battery that is completely empty.

The lithium-ion rechargeable battery can be charged at any charge level and charging can be interrupted at any time without damaging the battery (no memory effect).

OPERATION



DANGER

Risk of injury! The device may only be put into operation if there are no defects. If a part is defective it must be replaced before the device is used again.



WARNING

Risk of injury! Before starting work check the area and remove all objects which may be kicked up by the unit.

SWITCHING ON AND OFF

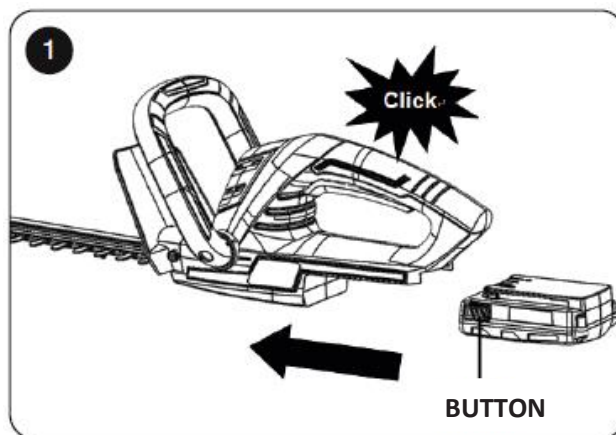

Ensure the battery is housed in the trimmer, with an audible click.

Switching on:

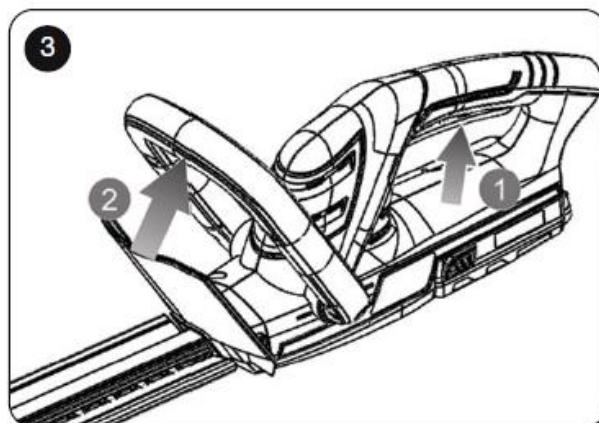

Pull the On/Off trigger upwards with your right hand.
Push in the safety lever with your left hand.

Switching off:

Release the On/Off trigger or safety lever.



WARNING

Never attempt to lock a switch in the ON position



INSTRUCTION MANUAL

TRIMMING INSTRUCTIONS

WORKING POSITION (Figure 4) – Maintain proper footing and balance and do not overreach. Wear safety goggles, non-skid footwear when trimming. Hold the unit firmly in both hands and turn the unit ON. Always hold the trimmer, as shown in the illustrations in this manual, with one hand on the trigger/rear handle and one hand on the safety lever. Never hold the unit by the hand.

TRIMMING NEW GROWTH (Figure 5) - A wide, sweeping motion, feeding the blade teeth through the twigs is most effective. A slight downward tilt of the blade, in the direction of motion gives the improved cutting.



CAUTION:

Do not cut stems greater than 16 mm. Use the trimmer only for cutting normal shrubbery around houses and buildings.

LEVEL HEDGES (Figure 6) – To obtain exceptionally level hedges, a piece of string can be stretched along the length of the hedge as a guide.

SIDE TRIMMING HEDGES (Figure 8) – Hold the trimmer as shown and begin at the bottom and sweep up.

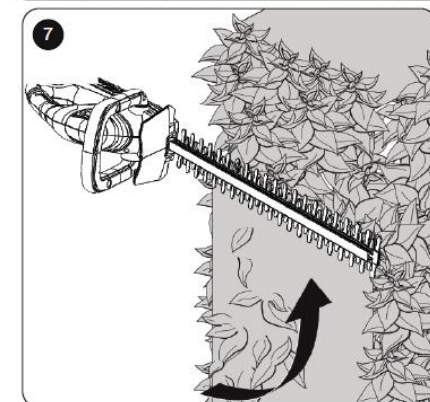
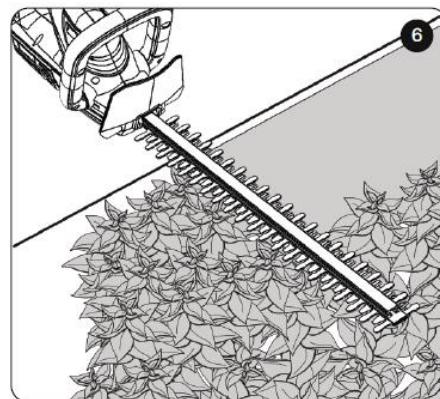
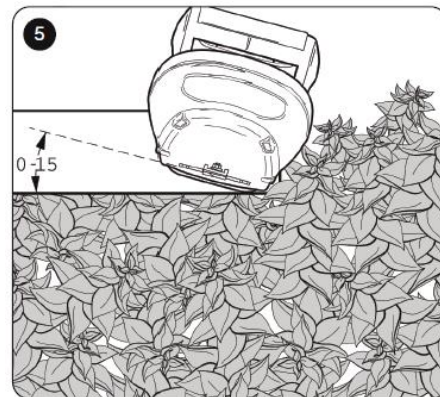
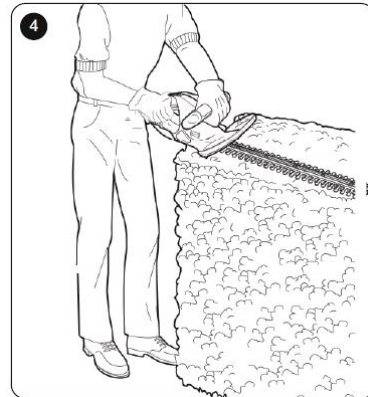

**WARNING**

To guard against injury, observe the following:

- Read this instruction manual before using. Save the instruction manual.
- Check the hedge for foreign objects, such as wire or fences before each use.
- Keep hands on handles. Don't overreach.
- Do not use under wet conditions.

**CAUTION**

Blade may coast after turning off.

**DANGER**

Keep hands away from blades.

CLEANING & MAINTENANCE

**DANGER**

Prior to conducting maintenance or cleaning: Remove the battery from the machine. The trimmer blade could still move after being switched off! Always remove battery before performing any work on the trimmer!

Note: Clean unit immediately after every use. Hedge debris when dry is very hard and are very difficult to remove.

BEFORE EACH USE

What?	How?
Check the battery, charger and machine for damage.	Conduct a visual inspection and have any faulty component replaced.

IF NECESSARY

What?	How?
Cleaning the device	Use a clean soft brush or damp cloth.
Lubricate blades	With a rust preventative solution or light machine oil

MAINTENANCE

A plastic blade cover is supplied with your trimmer for storing. Remove the battery and slip the hedge trimmer blade into the sheath, as shown in (Figure 8).

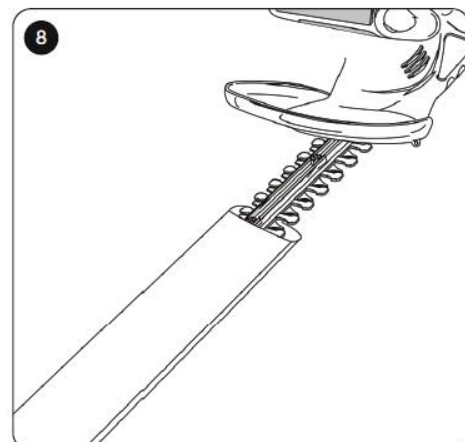



INSTRUCTION MANUAL



WARNING

Remove battery before servicing, cleaning or removing material from the gardening appliance. The cutting blades are made from high quality, hardened steel and with normal usage, they will not require sharpening. However, if you accidentally hit a wire fence (figure 9), stones, glass or other hard objects, you may put a nick in the blade. There is no need to remove this nick as long as it does not interfere with the movement of the blade. If it does interfere, remove the battery and have an approved service dealer, use a fine-toothed file or sharpening stone to remove the nick. If you drop the trimmer, carefully inspect it for damage. If the blade is bent, housing cracked, or handles broken or if you see any other condition that may affect the trimmer's operation, contact your local approved service dealer for repairs before putting it back into use.

Fertilisers and other garden chemicals contain agents which greatly accelerate the corrosion of metals. Do not store the unit on or adjacent to fertilisers or chemicals.

With the battery removed, use only mild soap and a damp cloth to clean the unit. Never let any liquid get inside the unit; never immerse any part of the unit into a liquid. Prevent the blades from rusting by applying a film of light machine oil after cleaning.

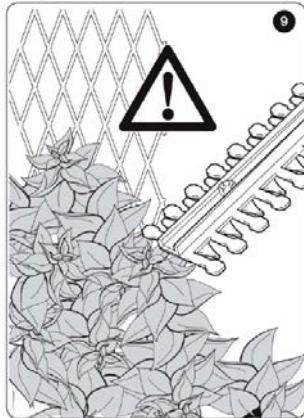

STORAGE & TRANSPORTATION

STORAGE

Store the tool in a dry and well-ventilated place.

TRANSPORTATION

Always remove the battery from the machine and ensure the blade guard is securely place over the blade assembly, when transporting the product.

TROUBLE SHOOTING



Switch off the trimmer and disconnect the battery before inspecting, cleaning or working on the thread.

Error/Fault	Cause	Remedy
Slow running, noisy or hot blades.	Dry, corroded blades.	Lubricate blades with rust preventative solution or light machine oil.
	Blades or blade support bent.	Straighten blade or blade support. To be actioned by an approved service dealer.
	Bent or damaged teeth.	Straighten teeth. To be actioned by an approved service dealer.
	Loose blade bolts.	Tighten blade bolts.
Unit will not start.	Battery not installed properly.	Check battery installation.
	Battery not charged.	Check battery charging requirements.
	Safety Lever not fully operated.	Check that safety lever is fully pulled back prior to moving trigger.
Battery won't charge.	Battery not inserted into charger.	Insert battery into charger until green LED appears. Charge up to 4 hours if battery totally drained.
	Charger not plugged in.	Plug charger into a working outlet. Refer to "Important Charging Notes" for more details.
		Check current at outlet by plugging in a lamp or other appliance.
Surrounding air temperature too hot or too cold	Move charger and tool to an area which has a temperature of above 40° degree F (4.5°C) or below 105° degree F (+40.5°C).	

If you can't fix the fault yourself, contact your retailer. Please be aware that any improper repairs will also invalidate the warranty and additional costs may be incurred.

PARTS DIAGRAM

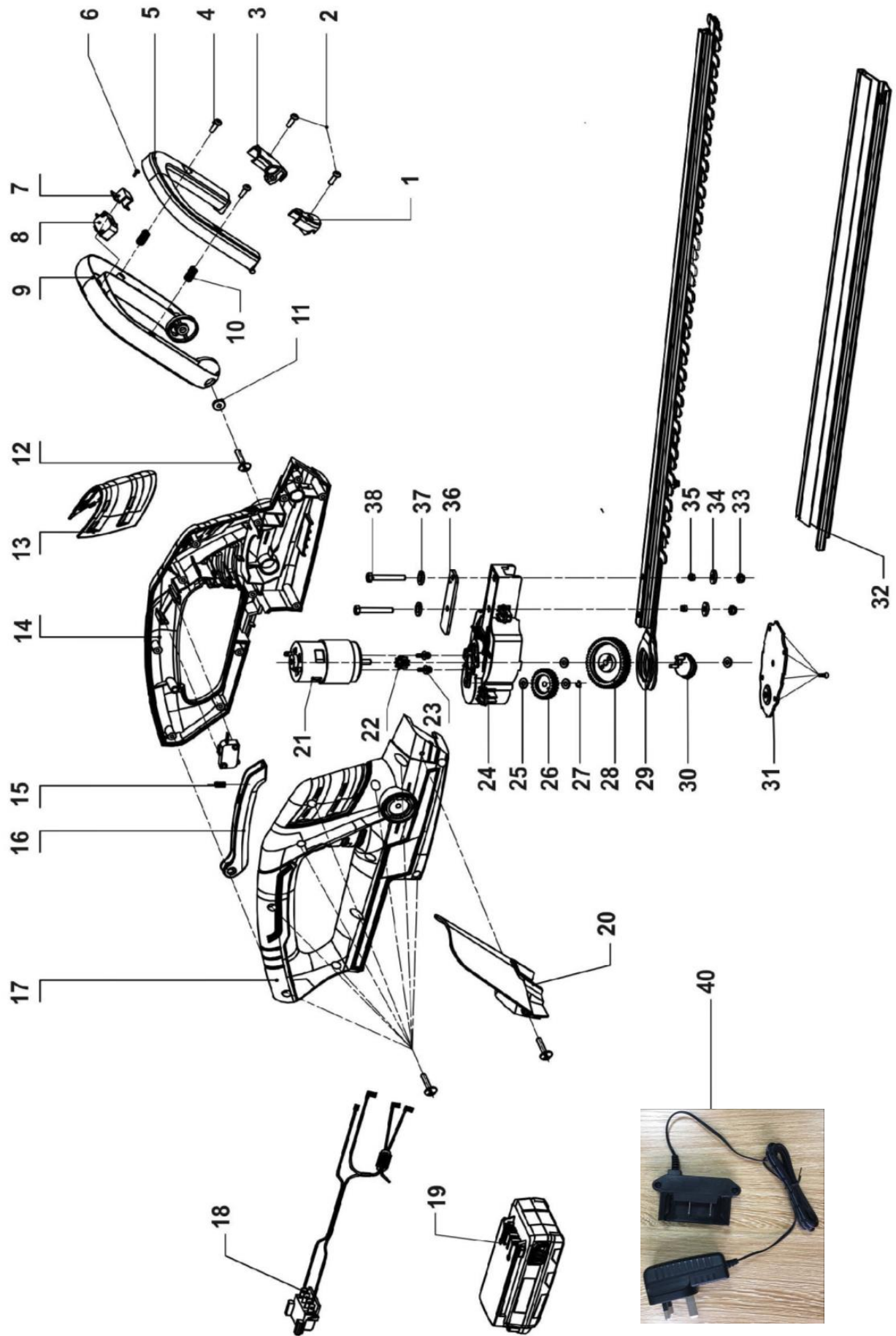

PARTS LIST

Item No	Webb Part No.	Description	QTY	Item No	Webb Part No.	Description	QTY
1	WE144-301062870	Handle Right Cap	1	21	WE144-102010429	Motor Assembly	1
2	WE124-104030136	Self-Tapping Screw ST4.2x15	25	22	WE144-103070102	Motor Gear	1
3	WE144-301062871	Handle Left Cap	1	23	WE144-104030081A	Triple Screw Assembly	2
4	WE144-104030370	Cross Head Tapping Screw	2	24	WE144-301062873-1	Gearbox Assembly	1
5	WE144-301062872	Safety Lever	1	25	WE144-104010149	Shim	5
6	WE144-104030427	Self-Tapping Screw	2	26	WE144-103070101	Mid Gear	1
7	WE144-103020092	Switch Fixing Frame	1	27	WE124-104050028	Split Washer	1
8	WE144-102020110	Switch	2	28	WE144-103070100	Big Gear Wheel	1
9	WE144-301062873	Handle	1	29	WE144-4990076-1	Blade Assembly	1
10	WE144-103060234	Safety Lever Spring	2	30	WE144-103070099	Eccentric Gear	1
11	WE144-104010018	Flat Washer	2	31	WE144-103990626	Gear Box Cover	1
12	WE132-104040161	Cross Head Screw	2	32	WE144-301062752	Blade Cover	1
13	WE144-301062874	Motor Cover	1	33	WE125-104020017	Lock Nut	2
14	WE144-301062875	Left Housing Assembly	1	34	WE144-103040103	Flat Washer 2	2
15	WE137-103060073	Trigger Spring	1	35	WE144-103990627	Washer	2
16	WE143-301062665	Trigger	1	36	WE144-103990628	Support Bar	1
17	WE144-301062876	Right Housing Assembly	1	37	WE144-104010086	Spring Washer	2
18	WE144-4100138	Internal Conductor Assembly	1	38	WE144-104040178	Hex Bolt	2
19	WEV202AH	Battery Assembly	1	40	WE143-CHARGER	Charger 0.5ah Assembly	1
20	WE144-301062877	Hand Shield	1				



EC DECLARATION OF CONFORMITY

We Handy Distribution Ltd - SN3 5HY (Importer) declare that the product:

Designation: Lithium-ion Battery Hedge Trimmer

Model(s): WEV20HT

Product Number: 1938201001

Type/Serial No. As per rating label on machine

Battery: 18Vd.c - 20V d.c Max

No Load Speed: 1200 rpm

Max. Cutting Width: 16 mm

This machine conforms to EU Directives, to which this declaration relates & corresponds to the relevant basic safety and health requirements of Directive:

Machinery Directive 2006/42/EC

EMC Directive 2014/30/EU

For the relevant implementation of the safety and health requirements mentioned in the Directives, the following standards and/or technical specification(s) have been respected:

EN 60745-1:2009+A11:2010, EN 60745-2-15:2009+A1:2010

EN 55014-1:2017, EN 55014-2:2015

Guaranteed Sound Power Level: $L_{WA} = 90\text{dB(A)}$

Vibration Level: Front Handle 1.55 m/s^2 , Rear Handle 1.58 m/s^2 (Uncertainty K: 1.5 m/s^2)

Notified Body:

Intertek Testing Services Shanghai

Addresses:

Building No. 86, 1198 Qinzhou Road (North), Shanghai 200233, China

Authorised signatory and technical file holder

Date: 07/01/2019

Name: Mr Simon Belcher

Signature:

Position: Chairman

Company: Handy Distribution Ltd

Address: Murdock Rd, Swindon, Wiltshire, SN3 5HY.



INSTRUCTION MANUAL

This Service Book is provided with your Webb, to help you look after your purchase to our recommendations and enable you to take advantage of the conditional manufacturer domestic warranty*.

Present this service book to your authorised Webb repair dealer, whenever a service or a warranty appraisal is required.

The booklet is applicable to the following products, in the UK only:

- Ride On Lawn Tractors
- Cylinder Lawnmowers
- Petrol Rotary Lawnmowers
- Petrol Hand Held Range

Please register your machine using the following pages or at www.webbgardenpower.co.uk. By registering your machine, you agree to maintain the machine in accordance with the service schedules specified in this manual and services duly recorded. (Not applicable for Webb electric handheld machines). You may be asked to produce this booklet as proof of servicing in the event of a claim. Proof of purchase should also be kept as a reference.

Ensure you have the following information available from your machine product label. The two examples below can be found on your machine:



1. Model Number

2. Serial & Product Number

Please complete using BLOCK CAPITALS.
Sections marked* must be completed to validate Warranty.

1. Users Statement of Warranty

Each new machine is warranted against defective material or assembly of material under normal usage. The warranty applies to the original purchaser, is not transferable and covers faulty parts and the labour involved in replacing and repairing those parts, which are of original manufacture.

2. Period of Warranty

Webb (excludes Electric Handheld) & Webb Pro, 2 year conditional warranty from the original date of sale to the first domestic user.

Webb Electric Handheld & Dynamic, Legacy & Heritage 1 year warranty from the original date of sale to the first domestic user.

90 days from the original date of sale to the professional/commercial or for hire user.

Engine warranty as per the engine manufacturer's warranty, which will be supplied with the machine.

90 days from the original date of sale for Replacement Spare Parts

All machines' must be serviced within the first 14 months from the original date of purchase, to qualify for a second year parts & labour warranty, details of the service must be recorded in the service record within this manual.

A reduced warranty period of 90 days applies to those items which are subject to normal wear and tear and in normal use, will need replacement or adjustment.

These items are chargeable after 90 days of ownership.

Filters
Tyres / Wheels
Drive chains and belts
Brake & clutch friction components
Control cable & starter cords
Fluids & lubricants
Spark plugs
Blades (Lawnmowers & Brushcutters)
Cutter bars (Hedgecutters)
Drive & clutch cable surfaces
Nylon Lines (Line Trimmers)
Carburettor cleaning
Bearings
Bushes
Electric cable
Grass collectors

3. Not covered by this warranty

(a) The warranty policy does not cover any depreciation or damages caused by ordinary wear, rusting or corrosion, lack of correct maintenance or operation, misuse, abuse, lack of transportation or accident.

(b) The warranty policy does not cover any costs necessary for the standard periodic maintenance services instructed by the operators manual, or service parts replacement which would include oil, filters, tyres, belts, brake linings, fuses, blades, seals and other service parts unless it can be proven that the item has evidence of faulty manufacture.

(c) The warranty policy will not cover failure or damage caused as a result of parts or accessories being modified without the written approval of GJ Handy & Co Ltd.

(d) The warranty policy will not cover the unit if non-genuine parts have been fitted and as a result damage has occurred to the unit.

(e) The warranty policy is non-transferable and is only applicable to the original purchaser.

4. Disclaimer

(a) This warranty is only a remedy for defect of products. GJ Handy & Co Ltd will never warranty in terms of the merchantability or the fitness for a particular purpose.

(b) No person is authorised to make any warranties, representations or promises, expressed or implied, on behalf of



INSTRUCTION MANUAL

GJ Handy & Co Ltd, or to modify the terms conditions or limitation of this warranty policy in any way.

(c) Neither GJ Handy & Co Ltd nor any company affiliated with GJ Handy & Co Ltd shall be liable in any event or manner whatsoever for incidental or consequential damages or injuries, including, but not limited to, loss of crops, loss of profit, out of pocket expenses or profits, rental of substitute equipment or other commercial losses.

5. General

(a) Most warrantable failures show up within the first few weeks of use. These failures are usually straightforward and warranty assessment is relatively easy.

(b) Failures relating to cutter decks and belts need careful investigation, as the cause may not always be straightforward. Look for damage to blades and pulleys especially when the cutter belt or blade boss have snapped or cracked as this could be due to impact damage.

(c) Customers should always refer to the operator/instruction manual when any disputed problem arises, you will find most areas covered within the manual.

Protecting your machine

Maintenance

Regular maintenance of your Webb machine is essential to ensure it operates, safely, efficiently and therefore reducing the environmental impact.

It is the owner's responsibility to ensure that their Webb machine is maintained at specific intervals. Any approved Webb service dealer can undertake a service, which are specialised in our products and will be aware of your particular machine and any technical updates which will save valuable time & money.

If you are using your machine in dry, dusty or high temperatures, you will need to service the machine more regularly.

Fuel (if applicable)

Due to ongoing efforts by fuel companies to reduce emissions, unleaded petrol will oxidize & deteriorate in storage overtime, leaving residue from detergent components.

Fuel deterioration problems may occur when petrol is stored for over 30 days. If you are planning to store fuel for over 30 days, we recommend you add Handy Parts Sure-Start fuel stabilizer to fresh fuel after purchasing. Sure-Start cannot reconstitute stale fuel.

Storage

When storing your machine for an extended period, we do recommend that you follow the instructions of engine instruction manual.

Always store the fuel in a clean, approved and sealed container. If the container is steel, ensure it is not corroded. If the container is not filled to its recommended capacity, air can accelerate fuel deterioration.

Always store fuel away from direct sunlight, in a dark, cool environment.

Your servicing Webb approved dealer will stamp & date the below relevant sections, when the correct service actions have been completed.
PLEASE ENSURE THE SERVICE BOOK IS AVAILABLE FOR THE DEALER, DURING SERVICE WORK.

1st Service

This must be stamped by an approved service dealer to qualify for a free second year warranty.
(Excluding the Webb Electric Handheld machines)

12 Months

Date

24 Months

Date

36 Months

Date



INSTRUCTION MANUAL

48 Months

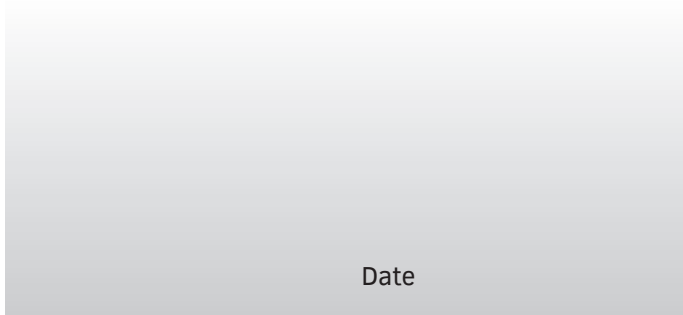

60 Months

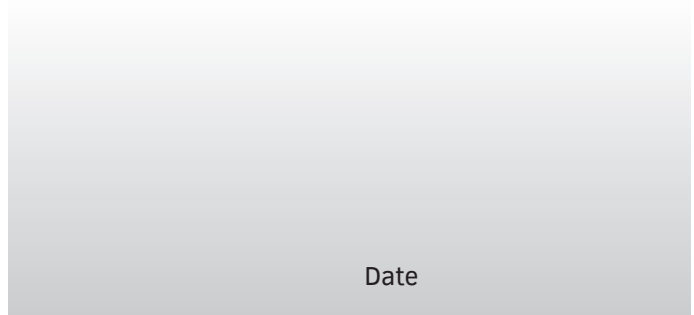

72 Months

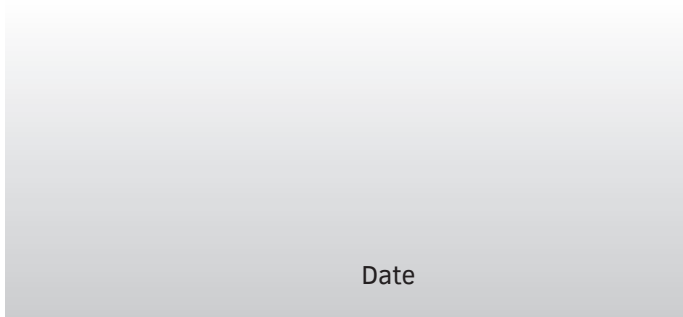

84 Months

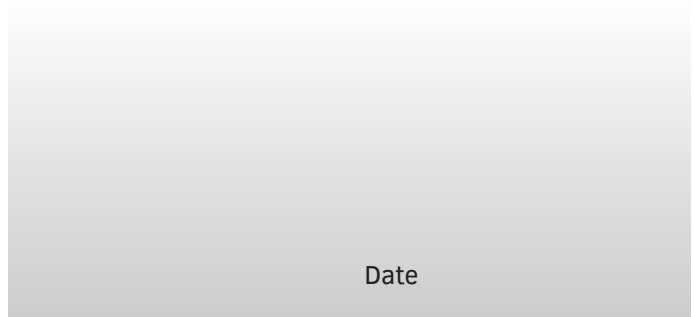

96 Months

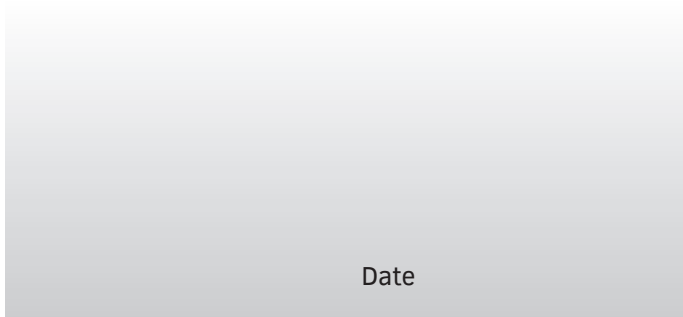

108 Months

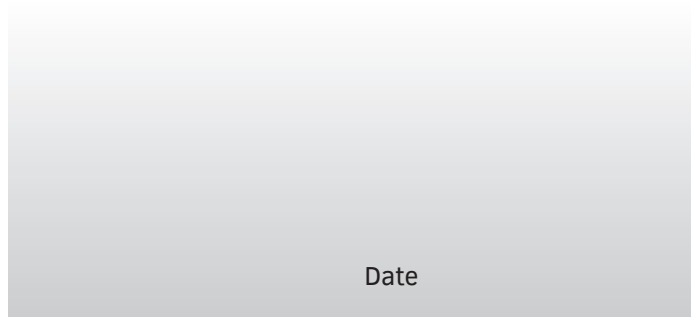

120 Months

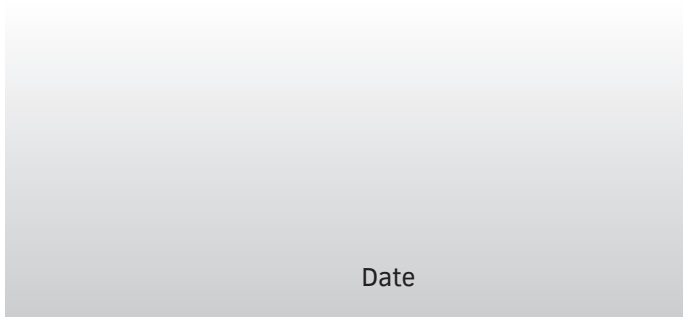

132 Months

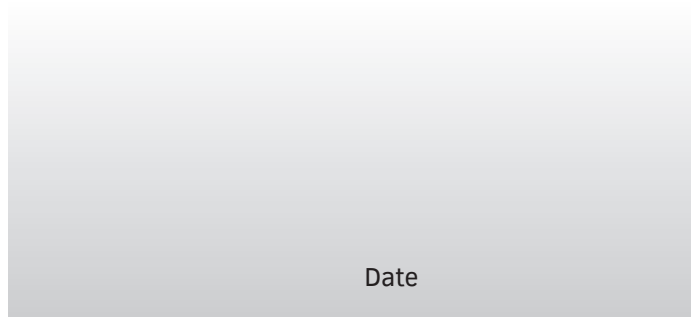

Product Information (* Compulsory)

If you have registered online, this form is not necessary.
PLEASE POST THIS COPY TO THE ADDRESS OVERLEAF

*Model No:	
*Product No:	
*Serial No:	
*Date of Purchase:	

Personal Information (* Compulsory)

*Title		*Forename		*Surname	
*House Number		*House Name			
*Address 1					
*Address 2					
*Town					
*County					
*Postcode					
Home Tel			Mobile Tel		
Email					

Age	18 to 25		26 to 35		36 to 45		46 to 60		61 to 80		81 & over
*Usage	Domestic Use			Commercial/Professional/Hire Use							

*Dealer Stamp (if available)



*Selling Retailer (If dealer stamp not available)

*Dealer Name	
*Dealer Address	
*Date of Purchase	

Webb Lawnmowers privacy commitment to machine owners.

The information supplied, helps us to improve the products & services we provide, including information that we believe is relevant to your and/or your machine. We value your trust by giving us this information about yourself and we are committed to protecting your privacy.

Webb, its associated companies, authorised dealers or third parties working on our behalf may wish to contact you regarding **PRODUCT RECALLS** specific to your machine. Please advise how you wish to be contacted for this specific reason only:

Post Telephone Email

From time to time Webb, its associated companies, authorised dealers or third parties working on our behalf may wish to contact you regarding our products, services, offers or just opinions, which may be used for marketing, research or analysis purposes.

If you wish to be contacted by any of the following methods, please tick the relevant boxes:

Post Telephone Email

You may give Webb Lawnmowers notice in writing at any time that you no longer wish to receive direct marketing communications

Webb Lawnmowers
Murdock Road
Dorcan
Swindon
Wiltshire
SN3 5HY